

Flexible Couplings



TB Wood's

TB Wood's is an industry leading designer and manufacturer of mechanical power transmission equipment for industrial control. Our mechanical product lines include: clutch and brake, synchronous and belted variable speed drives; grid, disc, jaw, gear coupling and elastomeric coupling products; sheaves and bushings. Registered trademarks include Sure-Flex Plus®, Dura-Flex®, G-Flex®, and Sure-Grip®.

TB Wood's was founded in 1857 and began as a foundry producing wood burning stoves. Our company's tradition of product innovation started early. TB Wood's entered the power transmission industry at the turn of the century with the introduction of flat belted drives and line shafting.

VISIT US ON THE WEB AT
TBWOODS.COM



Table Of Contents

SECTION	PAGES	
F1	Couplings – Sure-Flex Plus®	Selection Data 1-8 Dimensions 9-17 Installation 18
F2	Couplings – Dura-Flex®	Selection (English) 1-6 Selection (Metric) 7-11
F3	Couplings – L-Jaw	Selection 1-6
F4	Couplings – G-Flex	Selection 1-10
F5	Couplings – Form-Flex® & Torsiflex-i	Product Features and Options 3 Disc Coupling Advantages 3 Typical Applications 3 Coupling Application Types 4 Coupling Selection Process 5 Coupling Selection Guide 6 Standard Bore Tolerances 7 Industry Standard Reference 8 Dynamic Balance Recommendations 8 Disc Coupling Misalignment Discussion 8 Product Differentiation 9 Spacer Couplings 11-18 Floating Shaft Couplings 19-24 Closed Coupled Couplings 25-28 Single Flex Couplings 29-32 Heavy Duty Spacer Couplings 33-37 Coupling Repair Parts and Kits 38-39 Hub Options 40-41 Design Options 42-43 Bolt Thread Size 44 Bolt/Nut Tightening Torque 44 Application Data Sheet 45-46
F7	Rigid Couplings	AVS Selection 2-5

Sure-Flex Plus® Elastomeric Couplings

F1



- **30% Higher Rating**
- **Quick, Easy Installation**
- **Clean, Quiet Performance**
- **No Lubrication, No Maintenance**

Table of Contents

Sure-Flex Plus® Table of Contents

Selection Guide	3-7
Components	3
Sleeve Selection	4
Sleeve Dimensions	5
Load/Service Factor	6
Coupling Ratings	7
Type J BTS Couplings	9
Type S BTS Couplings	10-11
Type B QD Bushed Couplings	11
Type SC BTS Spacer Couplings	12-15
Type C Clamp Hub Couplings	16
Installation Instructions	17

Sure-Flex Plus couplings are a TB Wood's original!



New! Sure-Flex® PLUS+

For over 50 years, TB Wood's has led the coupling industry with the original TB Wood's Sure-Flex design. And we haven't stopped innovating: this industry favorite just got even better. Our new Sure-Flex Plus EPDM and Neoprene sleeves are best-in-class for coupling performance and value. Here's why:

High Torque Rating

- **30% Increased Torque Rating**

Sure-Flex Plus sleeves provide longer service life in demanding applications, reducing required maintenance and associated replacement cost.

Longer Life

- **Sure-Flex Plus Lasts Over 3X Longer than the Competition**

Extensive testing shows our sleeves outlast the imitators. More uptime means less costly downtime.

Better Value

- **Save Money Using a Smaller Coupling**

Over 50% of common applications can now use a smaller coupling, lowering the cost of both coupling purchase and sleeve replacement.

Interchangeable

- **Retrofits to Existing Flanges**

No need to replace the full coupling – the Sure-Flex Plus sleeve design is 100% compatible with the current industry standard created by TB Wood's over 50 years ago.

Sure-Flex Plus couplings utilize EPDM, Neoprene, Hytrel™ and Urethane flexible elastomer sleeves to transmit torque and accommodate shaft misalignment. Sure-Flex Plus couplings have exceptional torsional flexibility, with the 4-way flexing action absorbing virtually all types of shock, vibration, misalignment and end float. Sure-Flex Plus couplings are an excellent choice when low cost, high flexibility, low vibration and easy installation are important.

Easy, Quick Installation

Sure-Flex Plus can be installed quickly and easily, thanks to its simple design with no bolts, gaskets, covers or seals. Alignment can be checked on the precision-machined flanges using only a straightedge and calipers. No special tools are needed for installation, alignment or removal.



Features

- Up to 72,480 in.lbs.; 8.20 kNm
- Quick and easy installation
- Spacer, bushed hub, and clamping hub designs in stock
- Flexible design accommodates misalignment and protects equipment
- 7° to 21° torsional wind up
- Needs no lubrication, no maintenance

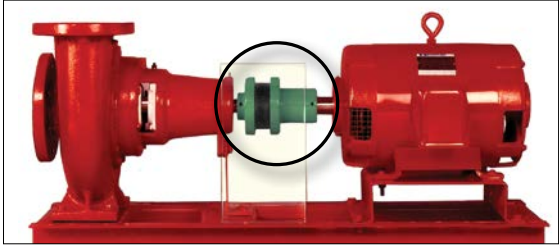

No Lubrication, Trouble-Free Operation

The teeth of the sleeve lock into the teeth of the flanges without clamps or screws, tightening under torque to provide smooth transmission of power. Couplings are not affected by abrasives, dirt or moisture, eliminating the need for lubrication or maintenance and providing clean, dependable, quiet performance.

Applications

Sure-Flex Plus couplings can be found hard at work in many industries. These couplings are ideal for a wide variety of applications including:

- Pumps
- Fans/Blowers
- Compressors
- Mixers
- Electric Motors
- Conveyors



Sure-Flex Plus 4-Way flexing action absorbs all types of shock, vibration and misalignment



Torsional

Sure-Flex Plus coupling sleeves have an exceptional ability to absorb torsional shock and dampen torsional vibrations. The EPDM and Neoprene sleeves wind up approximately 21° torsionally at their rated torque. Hytrel sleeves will wind up about 7°.



Angular

The unique design of the Sure-Flex Plus coupling's teeth allows for the absorption of angular misalignment without wear. Refer to page F1-18 for misalignment limits. Angular alignment can be achieved using only a scale and calipers.



Parallel

Parallel misalignment is absorbed without wear or appreciable energy loss. The lateral flexibility of the coupling sleeve minimizes radial bearing loads normally associated with parallel misalignment. This feature also allows for easier installation by the use of components bored for slip fits without fretting corrosion occurring at the shaft. Refer to page F1-18 for parallel misalignment limits. Only a straight-edge and feeler gage are required for parallel alignment.

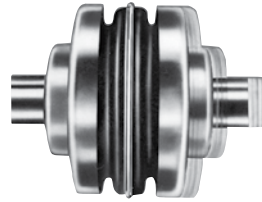

Axial

Sure-Flex Plus couplings may be used in applications with limited axial shaft movements. The axial compressibility of the EPDM and Neoprene sleeves allows for shaft end-float without the absolute transfer of thrust loads.

Sure-Flex Plus SELECTION GUIDE

Use the Coupling Selector Program on www.TBWoods.com/Select

Or follow these steps:

Sure-Flex Plus couplings are selected as component parts.

1. Determine SLEEVE material and type.
Refer to pages F1—4 & 5
2. Determine coupling SIZE.
Refer to pages F1—6, 7, & 8
3. Determine FLANGES to be used.
Refer to pages F1—9 thru 16

Specify coupling components.

- Example #1 - Close coupled
Size 6, Type S flange w 1-3/8 bore
Size 6, Type S flange w 1" bore
Size 6, Split EPDM sleeve
- Example #2 - 5" Between shaft spacer
Size 9, Type SC flange for #11 hub
Size 9, Type SC flange for #9 hub
Size 11 Hub w 2-3/8 bore
Size 9 Short hub w 1-1/8 bore
Size 9 Solid Hytrel sleeve

PROD. NUMBER	PROD. DESCRIPTION
6S138	6Sx1-3/8
6S1	6Sx1
6JS	6JES
9SC5011	9SC50-11
9SC50	9SC50
11SCH238	11SCH x 2-3/8
9SCHS118	9SCHS x 1-1/8
9H	9H

Sure-Flex Plus® Sleeve

Selection

Sure-Flex Plus Sleeves are available in four materials and various shape configurations.

New! Sure-Flex Plus EPDM and Neoprene sleeves have a 30% higher torque capacity.

	EPDM	Neoprene	Hytrel	Urethane
CONSTRUCTIONS AVAILABLE				
1 pc, unsplit	JE	JN	H	U
1 pc, split	JES	JNS	-	-
2 pc, E/N w/ring	E	N	HS	-
TYPICAL USE	General Purpose	Oil Resist Non-flame	General Purpose	Stiffness
REL. RATING	1X	1X	3X	3X
WIND-UP ANGULAR	21°	21°	7°	3°
MISALIGN	1°	1°	1/4°	1/4°
TEMPERATURE				
maximum	+275°F/+135°C	+200°F/+93°C	+250°F/+121°C	+200°F/+93°C
minimum	-30°F/-34°C	-0°F/-18°C	-65°F/-54°C	-80°F/-62°C

SURE-FLEX PLUS SLEEVES

Part No.	Product Description
3J	3JE EPDM
4J	4JE EPDM
5J	5JE EPDM
6J	6JE EPDM
7J	7JE EPDM
8J	8JE EPDM
9J	9JE EPDM
10J	10JE EPDM
3JS	3JES EPDM Split
4JS	4JES EPDM Split
5JS	5JES EPDM Split
6JS	6JES EPDM Split
7JS	7JES EPDM Split
8JS	8JES EPDM Split
9JS	9JES EPDM Split
10JS	10JES EPDM Split
3JN	3JN Neoprene
4JN	4JN Neoprene
5JN	5JN Neoprene
6JN	6JN Neoprene
7JN	7JN Neoprene
8JN	8JN Neoprene
3JNS	3JNS Neoprene Split
4JNS	4JNS Neoprene Split
5JNS	5JNS Neoprene Split
6JNS	6JNS Neoprene Split
7JNS	7JNS Neoprene Split
8JNS	8JNS Neoprene Split

Part No.	Product Description
4	4E EPDM
5	5E EPDM
6	6E EPDM
7	7E EPDM
8	8E EPDM
9	9E EPDM
10	10E EPDM
11	11E EPDM
12	12E EPDM
13	13E EPDM
14	14E EPDM
16	16E EPDM
4N	4N Neoprene
5N	5N Neoprene
6N	6N Neoprene
7N	7N Neoprene
8N	8N Neoprene
9N	9N Neoprene
10N	10N Neoprene
11N	11N Neoprene
12N	12N Neoprene
13N	13N Neoprene
14N	14N Neoprene

Part No.	Product Description
6H	6H Hytrel
7H	7H Hytrel
8H	8H Hytrel
9H	9H Hytrel
10H	10H Hytrel
11H	11H Hytrel
12H	12H Hytrel
6HS	6HS Split Hytrel
7HS	7HS Split Hytrel
8HS	8HS Split Hytrel
9HS	9HS Split Hytrel
10HS	10HS Split Hytrel
11HS	11HS Split Hytrel
12HS	12HS Split Hytrel
13HS	13HS Split Hytrel
14HS	14HS Split Hytrel
10U	10U Urethane
11U	11U Urethane
12U	12U Urethane

Selection

Flexible sleeves for Wood's Sure-Flex Plus couplings are available in four materials (EPDM, Neoprene, HytreI and Urethane) and in three basic constructions. Characteristics of the materials are given on page F1—4 and the various types are shown and described here.



JE, JN

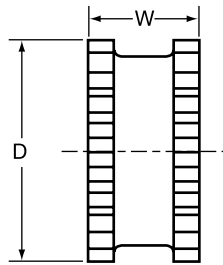

Types JES, JNS

JE-JES-JN-JNS

J sleeves are molded EPDM rubber (E) or Neoprene (N). They are available in one-piece solid construction (JE, JN) or one-piece split construction (JES, JNS). These sleeves may be used in any Sure-Flex Plus flange within a given size.



E and N
(Assembled)

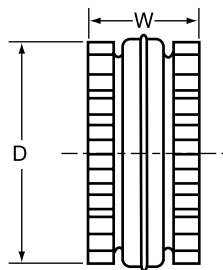

Types E and N
(Disassembled)

E-N

These sleeves are of two-piece design with a retaining ring. They are available in either EPDM (E) or Neoprene (N). They may be used with any flange within a given size. Sleeves are shown here assembled and disassembled.

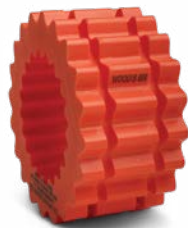

H or U

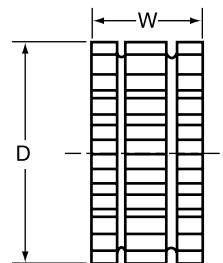

HS

H-HS-U

H (HytreI) and U (Urethane) sleeves, designed for high-torque applications, transmit four times as much power as an equivalent EPDM or Neoprene sleeve. Available in one-piece solid construction (H or U) or two-piece split construction (HS), these can be used only with S, C and SC flanges. They cannot be used with J or B flanges or as direct replacements for EPDM or Neoprene sleeves.

DIMENSIONS (in.)

Coupling Size	JE, JES, JN & JNS Sleeves EPDM & Neoprene			E and N Sleeves EPDM & Neoprene			H, U & HS Sleeves HytreI & Urethane		
	D	W	Weight (lbs.)	D	W	Weight (lbs.)	D	W	Weight (lbs.)
3	1-7/8	1	.06						
4	2-5/16	1-1/4	.10	2-5/16	1-1/4	.11			
5	2-15/16	1-9/16	.20	2-15/16	1-9/16	.25			
6	3-3/4	1-7/8	.40	3-3/4	1-7/8	.49	3-3/4	1-7/8	.44
7	4-11/32	2-3/16	.62	4-11/32	2-3/16	.77	4-11/32	2-3/16	.69
8	5-1/16	2-1/2	1.13	5-1/16	2-1/2	1.4	5-1/16	2-1/2	1.4
9*	6	3	1.46	6	3	2.0	6	3	1.8
10*	7-1/16	3-7/16	2.32	7-1/16	3-7/16	3.2	7-1/16	3-7/16	2.9
11				8-3/16	4	5.1	8-3/16	4	4.5
12				9-9/16	4-11/16	8.1	9-9/16	4-11/16	7.3
13				11-3/16	5-1/2	13.0	11-3/16	5-1/2	11.8
14				13-3/32	6-1/2	21.1	13-3/32	6-1/2	19.3
16				17-29/32	8-3/4	45.3			

Sizes 13 and 14 HytreI available with HS sleeves only.

*All 9J and 10J sleeves available in EPDM only. Only sizes available in Urethane.

Sure-Flex Plus® Coupling

Selection

A. Select Load Symbol based on your driven machine.

Application	Load Symbol	Application	Load Symbol	Application	Load Symbol
AGITATORS—Paddle, Propeller, Screw	L	DEWATERING SCREEN (sewage)	M	MILLS	
BAND RESAW (lumber)	M	DISC FEEDER	L	Ball, Pebble, Rod, Tube, Rubber Tumbling . . .H	
BARGE HAUL PULLER	H	DOUGH MIXER	M	Dryer and Cooler	M
BARKING (lumber)	H	DRAW BENCH CONVEYOR and MAIN DRIVE	H	MIXERS	
BAR SCREEN (sewage)	L	DREDGES		Concrete, Muller	M
BATCHES (textile)	L	Cable Reel, Pumps	M	Banbury	H
BEATER AND PULPER (paper)	M	Cutter Head Drive, Jig Drive, Screen Drive . .H		ORE CRUSHER	H
BENDING ROLL (metal)	M	Maneuvering and Utility Winch, Stacker . . .M		OVEN CONVEYOR	L
BLEACHER (paper)	L	DYNAMOMETER	L	PLANER (metal or wood)	M
BLOWERS		DRYERS (rotary)	M	PRESSES	
Centrifugal, Vane	L	EDGER (lumber)	H	Brick, Briquette Machine	H
Lobe	M	ELEVATOR		Notching, Paper, Punch, Printing	M
BOTTLING MACHINERY	L	Bucket	M	PUG MILL	M
BREW KETTLES (distilling)	L	Escalator	L	PULP GRINDER (paper)	H
BUCKET ELEVATOR OR CONVEYOR	M	Freight, Passenger, Service, Man LiftH		PULVERIZERS	
CALENDERS		ESCALATORS	L	Hammermill—light duty, Roller	M
Calendar (paper)	M	EXTRUDER (metal)	H	Hammermill—heavy duty, Hog	H
Calendar-super (paper), Calender (rubber) . .H		FANS		PUMPS	
CANE KNIVES (sugar)	M	Centrifugal	L	Centrifugal, Axial	L
CARD MACHINE (textile)	H	Cooling Tower	H	Gear, Lobe, Screw, Vane	M
CAR DUMPERS	H	Forced Draft, Large Industrial or MineM		Reciprocating—sgl. or dbl. acting, cylinder	*
CAR PULLERS	M	FEEDERS		REEL, REWINDER (paper) CABLE	M
CEMENT KILN	H	Apron, Belt, Disc	L	ROD MILL	H
CENTRIFUGAL EQUIPMENT		Reciprocating	H	SAWDUST CONVEYOR	L
Blowers, Compressors, Fans, PumpsL		Screw	M	SCREENS	
CHEMICAL FEEDERS (sewage)	L	FILTER, PRESS-OIL	M	Air Washing, Water	L
CHILLER (oil)	M	GENERATORS		Rotary for coal or sand	M
CHIPPER (paper)	H	Uniform load	L	Vibrating	H
CIRCULAR RESAW (lumber)	M	Varying load, Hoist	M	SCREW CONVEYOR	L
CLARIFIER or CLASSIFIER	L	Welders	H	SLAB CONVEYOR (lumber)	M
CLAY WORKING MACHINERY	M	GRIT COLLECTOR (sewage)	L	SLITTERS (metal)	M
COLLECTORS (sewage)	L	GRIZZLY	H	SOAPERS (textile)	L
COMPRESSORS		HAMMERMILL		SORTING TABLE (lumber)	M
Centrifugal, Gear, Lobe, Screw	L	Light Duty, Intermittent	M	SPINNER (textile)	M
Reciprocating	*	Heavy Duty, Continuous	H	STOKER	L
CONCRETE MIXERS	M	HOISTS		SUCTION ROLL (paper)	M
CONVERTING MACHINE (paper)	M	Heavy Duty	H	TENTER FRAMES (textile)	M
CONVEYORS		Medium Duty	M	TIRE BUILDING MACHINES	H
Apron, Assembly Belt, Flight, Oven, Screw . .L		JORDAN (paper)	H	TIRE & TUBE PRESS OPENER	L
Bucket	M	KILN, ROTARY	H	TUMBLING BARRELS	H
COOKERS—Brewing, Distilling, FoodL		LAUNDRY WASHER or TUMBLER	H	WASHER and THICKENER (paper)	M
COOLING TOWER FANS	H	LINE SHAFTS	L	WINCHES	M
COUCH (paper)	M	LOG HAUL (lumber)	H	WINDERS, Paper, Textile, Wire	M
CRANES and HOISTS	M	LOOM (textile)	M	WINDLASS	M
Heavy Duty Mine	H	MACHINE TOOLS, MAIN DRIVE	M	WIRE	
CRUSHERS—Cane (sugar), Stone or OreH		MANGLE (textile)	L	Drawing	H
CUTTER—Paper	H	MASH TUBS (distilling)	L	Winding	M
CYLINDER (paper)	H	MEAT GRINDER	M	WOODWORKING MACHINERY	L
		METAL FORMING MACHINES	M		

*Consult Factory

B. Determine Service Factor using Load Symbol and driveR.

Load Symbol	L Light	M Medium	H Heavy
Standard AC Motor			
DC Shunt Motor	1.25	1.5	2.0
Engine, 8 or more cylinders			
High Torque AC Motor			
DC Series & Comp.	1.5	2.0	2.5
Engine, 4-6 cylinders			
Engine, 3 cylinders or less	2.0	2.5	3.0
Turbine	1.0	1.25	1.5

On applications involving varying torque loads, design around the maximum load. Then determine the resulting service factor at minimum load. If this value is greater than 5.2 for EPDM or Neoprene sleeves, or 4.0 for Hytrel sleeves, special coupling alignment will be required (see page F1—18).

Caution: Applications involving reciprocating engines and reciprocating driven devices are subject to rotational vibrational critical speeds which may destroy the coupling.

C. Determine Size using Coupling Rating Tables

- For 860, 1160, 1750 or 3500 RPM, use table on page F1-8.
- For other speeds, find the coupling size by calculating HP rating @100 RPM:

$$\text{HP @ 100 RPM} = \text{HP} \times \text{Service Factor} \times 100 / \text{coupling RPM}$$

In the table below, choose a coupling with a HP@100 rating greater than calculated above.

Example:

For 4 HP @ 55 RPM and 1.25 Service Factor:

$$\text{HP @ 100} = 4 \times 1.25 \times 100 / 55 = 9.1$$

Use #11 EPDM or Neoprene or #9 Hytrel

Do not exceed a 5.2 Service Factor for EPDM or Neoprene sleeves, or 4.0 for Hytrel sleeves.

Online Selection Tools

Coupling selection program, 3-D CAD models, e-catalog, and interchange guide make selecting the right coupling simple!

www.TBWoods.com/Couplings

New! Sure-Flex Plus EPDM and Neoprene sleeves have a 30% higher torque capacity.

COUPLING RATINGS

Size	EPDM Sleeves	Neoprene Sleeves	HP @ RPM				Torque (in. lbs.)	Stiffness (in. lbs./rad)	Max RPM
			100	1160	1750	3500			
3	JE,JES	JN,JNS	0.1	1.4	2.2	4.3	78	229	9200
4	E,JE,JES	N,JN,JNS	0.2	2.9	4.3	8.7	156	458	7600
5	E,JE,JES	N,JN,JNS	0.5	5.7	8.7	17	312	916	7600
6	E,JE,JES	N,JN,JNS	0.9	11	16	32	585	1718	6000
7	E,JE,JES	N,JN,JNS	1.5	17	26	52	940	2769	5250
8	E,JE,JES	N,JN,JNS	2.3	27	41	82	1475	4335	4500
9	E,JE,JES	N	3.7	43	65	130	2340	6875	3750
10	E,JE,JES	N	5.9	69	104	208	3735	10980	3600
11	E	N	9.3	108	164	327	5890	17300	3600
12	E	N	15	172	260	-	9360	27500	2800
13	E	N	23	272	410	-	14750	43350	2400
14	E	N	37	431	650	-	23400	68755	2200
16	E	-	75	870	-	-	47250	180480	1500
Size	Hytrel Sleeves	Urethane Sleeves	HP @ RPM				Torque (in. lbs.)	Stiffness (in. lbs./rad)	Max RPM
			100	1160	1750	3500			
6	H, HS		2.9	33	50	100	1800	10000	6000
7	H, HS		4.6	53	80	160	2875	20000	5250
8	H, HS		7.2	84	126	252	4530	30000	4500
9	H, HS		11	132	200	400	7200	47500	3750
10	H, HS	U	18	209	315	630	11350	100000*	3600
11	H, HS	U	29	331	500	1000	18000	125000*	3600
12	H, HS	U	50	580	875		31500	225000*	2800
13	HS		75	870	1312		47268	368900	2400
14	HS		115	1334	2013		72480	593250	2200

* Urethane values are 220000, 350000, and 600000.

Sure-Flex Plus® Coupling

Selection

EPDM or NEOPRENE SLEEVES

860 RPM MOTORS						1160 RPM MOTORS						1750 RPM MOTORS						3500 RPM MOTORS					
HP	Service Factors					HP	Service Factors					HP	Service Factors					HP	Service Factors				
	1.0	1.25	1.5	2.0	2.5		1.0	1.25	1.5	2.0	2.5		1.0	1.25	1.5	2.0	2.5		1.0	1.25	1.5	2.0	2.5
0.5	3	3	3	3	4	0.5	3	3	3	3	3	0.5	3	3	3	3	3	0.5	3	3	3	3	3
0.75	3	3	3	3	4	0.75	3	3	3	4	4	0.75	3	3	3	3	3	0.75	3	3	3	3	3
1	3	4	4	4	5	1	3	3	4	4	4	1	3	3	3	3	4	1	3	3	3	3	3
1.5	4	4	5	5	5	1.5	4	4	4	5	5	1.5	3	3	4	4	4	1.5	3	3	3	3	3
2	4	5	5	5	6	2	4	4	5	5	5	2	3	4	4	4	5	2	3	3	3	3	4
3	5	5	6	6	6	3	5	5	5	6	6	3	4	4	5	5	5	3	3	3	4	4	4
5	6	6	6	7	7	5	5	6	6	6	7	5	5	5	5	6	6	5	4	4	4	5	5
7.5	6	7	7	8	8	7.5	6	6	7	7	8	7.5	5	6	6	6	7	7.5	4	5	5	5	6
10	7	7	8	8	9	10	6	7	7	8	8	10	6	6	6	7	7	10	5	5	5	6	6
15	8	8	9	9	10	15	7	8	8	9	9	15	6	7	7	8	8	15	5	6	6	6	7
20	8	9	9	10	10	20	8	8	9	9	10	20	7	7	8	8	9	20	6	6	6	7	7
25	9	9	10	10	11	25	8	9	9	10	10	25	7	8	8	9	9	25	6	6	7	7	8
30	9	10	10	11	11	30	9	9	10	10	11	30	8	8	9	9	10	30	6	7	7	8	8
40	10	10	11	11	12	40	9	10	10	11	11	40	8	9	9	10	10	40	7	7	8	8	9
50	10	11	11	12	12	50	10	10	11	11	12	50	9	9	10	10	11	50	7	8	8	9	9
60	11	11	12	12	13	60	10	11	11	12	12	60	9	10	10	11	11	60	8	8	9	9	10
75	11	12	12	13	13	75	11	11	12	12	13	75	10	10	11	11	12	75	8	9	9	10	10
100	12	12	13	13	14	100	11	12	12	13	13	100	10	11	11	12	12	100	9	9	10	10	11
125	12	13	13	14	14	125	12	12	13	13	14	125	11	11	12	12	13	125	9	10	10	11	11
150	13	13	14	14	16	150	12	13	13	14	14	150	11	12	12	13	13	150	10	10	11	11	-
200	13	14	14	16	16	200	13	13	14	14	16	200	12	12	13	13	14	200	10	11	11	-	-
250	14	14	16	16	16	250	13	14	14	16	16	250	12	13	13	14	14	250	11	11	-	-	-
300	14	16	16	16	16	300	14	14	16	16	16	300	13	13	14	14		300	11	-	-	-	-
350	16	16	16	16	-	350	14	16	16	16	16	350	13	14	14	-	-	350	-	-	-	-	-
400	16	16	16	-	-	400	14	16	16	16	16	400	13	14	14	-	-	400	-	-	-	-	-
450	16	16	-	-	-	450	16	16	-	-	-	450	14	-	-	-	-	450	-	-	-	-	-
500	16	16	-	-	-	500	16	16	-	-	-	500	14	-	-	-	-	500	-	-	-	-	-
600	16	-	-	-	-	600	16	-	-	-	-	600	-	-	-	-	-	600	-	-	-	-	-
700	-	-	-	-	-	700	-	-	-	-	-	700	-	-	-	-	-	700	-	-	-	-	-
800	-	-	-	-	-	800	-	-	-	-	-	800	-	-	-	-	-	800	-	-	-	-	-

HYTREL or URETHANE SLEEVES

860 RPM MOTORS						1160 RPM MOTORS						1750 RPM MOTORS						3500 RPM MOTORS					
HP	Service Factors					HP	Service Factors					HP	Service Factors					HP	Service Factors				
	1.0	1.25	1.5	2.0	2.5		1.0	1.25	1.5	2.0	2.5		1.0	1.25	1.5	2.0	2.5		1.0	1.25	1.5	2.0	2.5
7-1/2	6	6	6	6	6	7-1/2	-	-	-	-	-	7-1/2	-	-	-	-	-	7-1/2	-	-	-	-	-
10	6	6	6	6	6	10	6	6	6	6	6	10	-	-	-	-	-	10	-	-	-	-	-
15	6	6	6	7	7	15	6	6	6	6	7	15	6	6	6	6	6	15	-	-	-	-	-
20	6	6	7	7	8	20	6	6	6	7	7	20	6	6	6	6	6	20	-	-	-	-	-
25	6	7	7	8	8	25	6	6	7	7	8	25	6	6	6	6	7	25	-	-	-	-	-
30	7	7	8	8	9	30	6	7	7	8	8	30	6	6	6	7	7	30	6	6	6	6	6
40	7	8	8	9	9	40	7	7	8	8	9	40	6	6	7	7	8	40	6	6	6	6	6
50	8	8	9	9	10	50	7	8	8	9	9	50	6	7	7	8	8	50	6	6	6	6	7
60	8	9	9	10	10	60	8	8	9	9	10	60	7	7	8	8	9	60	6	6	6	7	7
75	9	9	10	10	11	75	8	9	9	10	10	75	7	8	8	9	9	75	6	6	7	7	8
100	9	10	10	11	11	100	9	9	10	10	11	100	8	8	9	9	10	100	6	7	7	8	8
125	10	10	11	11	12	125	9	10	10	11	11	125	8	9	9	10	10	125	7	7	8	8	9
150	10	11	11	12	12	150	10	10	11	11	12	150	9	9	10	10	11	150	7	8	8	9	9
200	11	11	12	12	13	200	10	11	11	12	12	200	9	10	10	11	11	200	8	8	9	9	10
250	11	12	12	13	13	250	11	11	12	12	13	250	10	10	11	11	12	250	8	9	9	10	10
300	12	12	13	13	14	300	11	12	12	13	13	300	10	11	11	12	12	300	9	9	10	10	11
350	12	12	13	14	14	350	12	12	12	13	14	350	11	11	12	12	12	350	9	10	10	11	11
400	12	13	13	14	14	400	12	12	13	13	14	400	11	11	12	12	13	400	9	10	10	11	11
500	13	13	14	14	-	500	12	13	13	14	14	500	11	12	12	13	13	500	10	10	11	11	-
600	13	14	14	-	-	600	13	13	13	14	-	600	12	12	13	13	14	600	10	11	11	-	-
700	14	14	-	-	-	700	13	13	14	14	-	700	12	12	13	14	14	700	11	11	-	-	-
800	14	14	-	-	-	800	13	14	14	-	-	800	12	13	13	14	14	800	11	11	-	-	-
900	14	-	-	-	-	900	14	14	14	-	-	900	13	13	14	14	-	900	11	-	-	-	-
1000	-	-	-	-	-	1000	14	14	-	-	-	1000	13	13	14	14	-	1000	11	-	-	-	-

NOTE: Flange Bore capacity should be verified for selected coupling based on equipment shaft size

Type J Sure-Flex Plus® BTS

Selection For Close Coupled Applications

FLANGES

Type J flanges sizes 3, 4 and 5 are manufactured of sintered carbon steel. The powdered metal manufacturing process provides high dimensional accuracy and uniform material properties for high strength. Size 6 is made of high strength cast iron.

Flanges are bored-to-size for a slip fit on standard shafts. The outside face of the flange is precision machined, allowing the surface to be used to align the coupling without special tools.

Type J flanges can be used with EPDM and Neoprene sleeves. Each flange has a standard keyway, one setscrew over the keyway and one setscrew at 90° from the keyway.

COUPLINGS

Spacing between internal flange hubs equals G. Spacing between shafts should be greater than 1/8 in. and less than L minus .85 times the sum of the two bore diameters.

To order couplings, refer to the part number examples on page F1-3. When specifying Type J flanges, the coupling and bore sizes accompany the flange symbol "J". For example, 3J x 1/2 is 3J12.

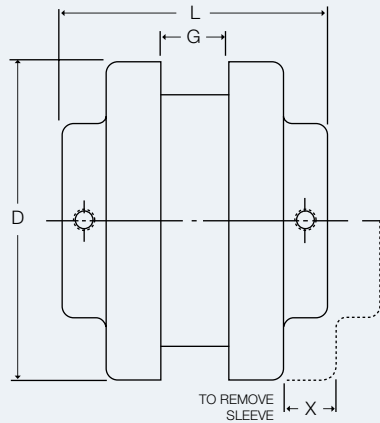
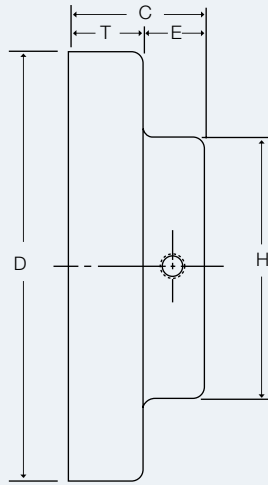

DIMENSIONS (in.)

Size	Dimensions									Wt. (lbs.)	STOCK BORES*																						
	C	D	E	G	H	L	T	X	Inches											Max Bore	Millimeters												
									3/8		1/2	5/8	3/4	7/8	15/16	1	1-1/8	1-3/16	1-1/4		1-3/8	9	11	12	14	15	16	19	20	24	25		
3J	51/64	2.062	13/32	3/8	1-1/2	1-31/32	25/64	5/8	0.3	X	X	X	X	X								7/8	-	X	X	X	X	X	X	-	-	-	
4J	55/64	2.500	27/64	43/64	1-5/8	2-25/64	7/16	5/8	0.4		X	X	X	X	X	X						1	-	-	-	X	X	X	X	X	X	X	X
5J	1-3/64	3.250	29/64	3/4	1-7/8	2-27/32	19/32	59/64	0.9		X	X	X	X	X	X	X					1-1/8	-	-	-	-	-	-	-	-	-	-	-
6J	1-5/16	4.000	9/16	7/8	2-1/2	3-1/2	3/4	1-3/32	1.2			X	X	X	X	X	X	X	X	X		1-3/8	-	-	-	-	-	-	-	-	-	-	-

■ Approximate weight for each flange.

* See page F1-10 for bore tolerances and page F1-13 for standard keyway dimensions.

Type S Sure-Flex Plus® BTS

Selection For Close Coupled Applications

COUPLINGS

Spacing between shafts should be greater than 1/8 in. and less than L minus .85 times the sum of the two bore diameters. Spacing between internal flange hubs equals $L - 2 \times C$.

To order couplings, refer to the part number examples on page F1-3.

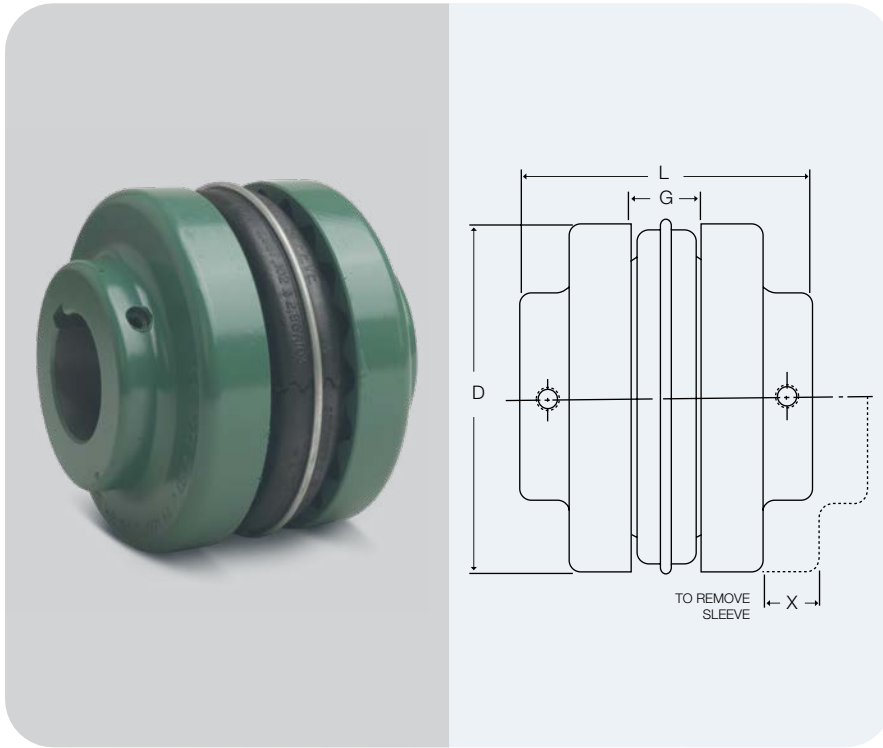

DIMENSIONS (in.)

STOCK BORES																				Max Bore		SHALLOW KEYSEAT DIMENSIONS ②														
Millimeters																				①	②	Bore	K.S.	Key	Bore	K.S.	Key	Bore	K.S.	Key						
14	15	16	19	20	24	25	28	30	32	35	38	42	45	48	50	52	55	60	65	70	80	90	Standard Keyseat	Shallow Keyseat	Bore	K.S.	Key	Bore	K.S.	Key	Bore	K.S.	Key			
X	X	X	X	X	X	X	X																1-3/16	1-1/4	1-1/4	1/4 X 1/16	1/4 X 3/16 X 1-3/8	-	-	-	-	-	-			
	X		X	X	X	X	X	X	X	X														1-7/16	1-1/2 ④	-	-	-	-	-	-	-	-	-		
											X													-	1-3/4	1-1/2 & 1-5/8	3/8 X 1/8	3/8 X 5/16 X ③	1-3/4	3/8 X 1/16	3/8 X 1/4 X 1-1/4	-	-	-		
																								-	1-7/8	-	-	-	-	-	-	-	1-7/8	1/2 X 1/16	1/2 X 5/16 X 1-9/16	
			X	X	X	X	X	X	X	X	X	X												1-5/8	1-7/8	1-7/8	1/2 X 1/8	1/2 X 3/8 X 1-7/8	-	-	-	-	-	-		
				X	X	X	X	X	X	X	X	X	X											1-15/16	2-1/4 ④	2-1/8	1/2 X 3/16	1/2 X 7/16 X 2-1/8	-	-	-	-	-	-		
																								-	2-3/8	-	-	-	2-3/8	5/8 X 1/8	5/8 X 7/16 X 1-7/8	-	-	-		
				X			X	X		X	X	X	X											2-1/2	2-3/4 ④	-	-	-	-	-	-	-	-	-		
																								-	2-7/8	2-7/8	3/4 X 1/8	3/4 X 1/2 X 2-1/4	-	-	-	-	-	-		
							X	X	X	X	X	X	X	X	X	X								2-3/4	3-1/8 ④	2-7/8	3/4 X 1/4	3/4 X 5/8 X 2-3/4	-	-	-	-	-	-		
																								-	3-3/8	-	-	-	3-3/8	7/8 X 3/16	7/8 X 5/8 X 2-5/8	-	-	-		
											X	X	X	X			X	X	X	X				3-3/8	3-7/16 ④	3-7/16	7/8 X 3/16	7/8 X 5/8 X 3-7/16	-	-	-	-	-	-		
																								-	3-7/8	3-7/8	3-7/8	1 X 1/4	1 X 3/4 X 3	-	-	-	-	-	-	
														X			X	X	X	X	X			3-7/8	3-15/16	-	-	-	-	-	-	-	-	-	-	
																								4-1/2	-	-	-	-	-	-	-	-	-	-	-	
																								5	-	-	-	-	-	-	-	-	-	-	-	-
																								5-1/2	6	-	-	-	-	-	-	-	-	-	-	-

① See charts on page F1 — 13
 ② Some large bore Type S flanges are supplied with shallow keyseats. In these cases, a rectangular key is furnished. The bores involved are listed above.
 ③ 1-5/8 for 1-1/2 bore, 1-5/16 for 1-5/8 bore.
 ④ Altered bores available only up to this diameter.

Type B Sure-Flex Plus® QD Bushed

Selection For Close Coupled Applications

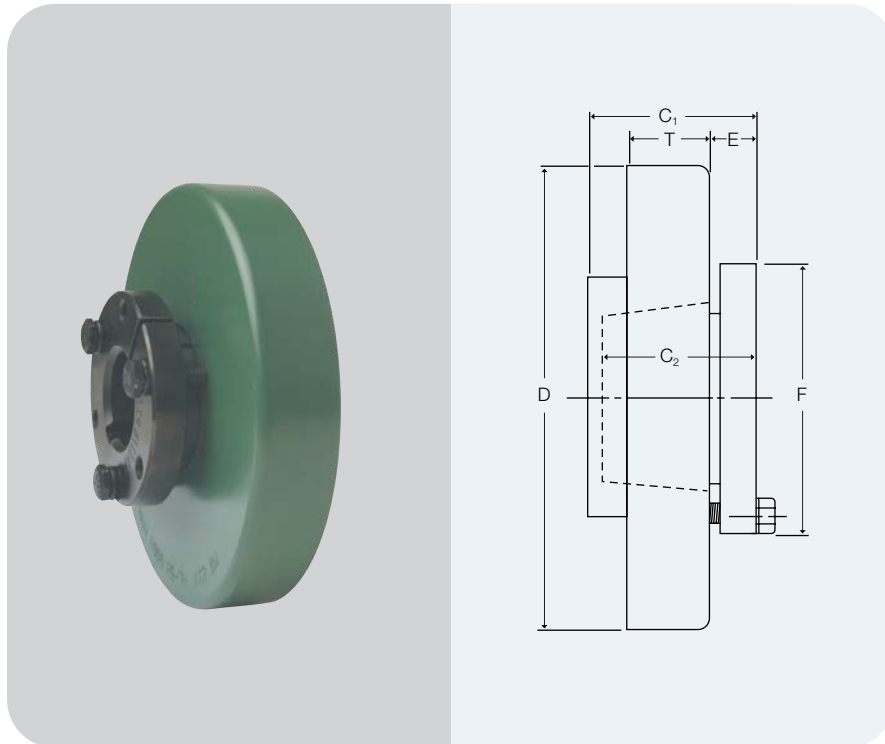

FLANGES

Type B flanges are made of high-strength cast iron and are designed to accommodate Wood's Sure-Grip Bushings for easy installation and removal.

BUSHINGS

Sure-Grip Bushings offer convenient mounting of the flange to the shaft securely without setscrews. They are tapered and are split through both the bushing flange and taper to provide a clamp fit, eliminating wobble, vibration and fretting corrosion. This is the same bushing used in Wood's sheaves and pulleys and is readily available everywhere.

Dimensions (in.)

Size	Bushing Required	Dimensions									Max Bore*	Weight (lbs.) ■	
		C ₁	C ₂	D	E	F	G	L	T	X		Flange	Bushing
6B	JA	1-7/32	1	4.000	15/32	2	7/8	3-3/8	25/32	1-3/32	1-1/4	1.4	.8
7B	JA	1-5/8	1	4.625	15/32	2	1	3-1/2	25/32	1-5/16	1-1/4	1.9	.8
8B	SH	1-29/32	1-1/4	5.450	9/16	2-11/16	1-1/8	4-1/16	29/32	1-1/2	1-5/8	2.9	1.0
9B	SD	2-1/4	1-13/16	6.350	5/8	3-3/16	1-7/16	4-3/4	1-1/32	1-3/4	1-15/16	4.8	1.5
10B	SK	1-15/16	1-7/8	7.500	23/32	3-7/8	1-5/8	5-1/2	1-7/32	2	2-1/2	7.8	2.0
11B	SF	2-3/16	2	8.625	11/16	4-5/8	1-7/8	6-1/4	1-1/2	2-3/8	2-15/16	12.0	3.5
12B	E	2-23/32	2-5/8	10.000	29/32	6	2-5/16	7-1/2	1-11/16	2-11/16	3-1/2	18.0	9.0
13B	F	3-3/4	3-5/8	11.750	1-1/16	6-5/8	2-11/16	8-3/4	1-31/32	3	3-15/16	31.2	14.0
14B	F	3-3/4	3-5/8	13.875	1-1/16	6-5/8	3-1/4	9-7/8	2-1/4	3-1/2	3-15/16	51.4	14.0
16B	J	4-13/16	4-1/2	18.875	1-1/4	7-1/4	4-3/4	12-3/4	2-3/4	4-1/4	4-1/2	120.0	22.0

* Maximum bore with keyseat.

■ Approximate weight for each flange.

Type B Sure-Flex Plus® QD Bushed

Selection For Close Coupled Applications

COUPLINGS

Type B Sure-Flex Plus Couplings can use EPDM or Neoprene sleeves. **Do not use Hytrel sleeves with Type B couplings.**

Spacing between internal flange hubs equals L minus 2 times C₂. Spacing between shafts should be greater than 1/8 in. and less than G.

To order complete couplings, specify coupling size with flange symbol (B) and bushing. Refer to page F1-3 to order the required coupling. Refer to charts below for bushings.

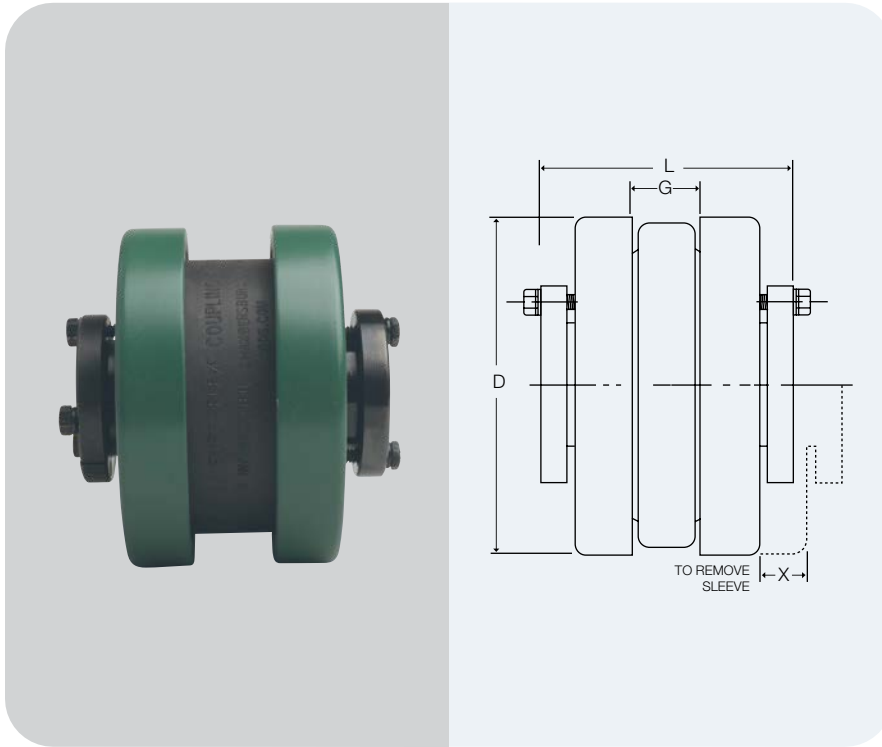

SURE-GRIP® BUSHING KEYSEAT DIMENSIONS (in.)

Bushing	Bores	Keyseat
JA	1/2 – 1	Standard ①
	1-1/16 – 1-3/16	1/4 x 1/16
	1-1/4	1/4 x 1/32
SH	1/2 – 1 3/8	Standard ①
	1-7/16 – 1 5/8	3/8 x 1/16
	1-11/16	No K.S.
SD	1/2 – 1-11/16	Standard ①
	1-3/4	3/8 x 1/8
	1-13/16	1/2 x 1/8
	1-7/8 – 1-15/16	1/2 x 1/16
SK	2	No K.S.
	1/2 – 2-1/8	Standard ①
	2-3/16 – 2-1/4	1/2 x 1/8
J	2-5/16 – 2 1/2	5/8 x 1/16
	2-9/16 – 2 5/8	No K.S.

Bushing	Bores	Keyseat
SF	1/2 – 2-1/4	Standard ①
	2-5/16 – 2-1/2	5/8 x 3/16
	2-9/16 – 2-3/4	5/8 x 1/16
	2-13/16 – 2-7/8	3/4 x 1/16
	2-15/16	3/4 x 1/32
E	7/8 – 2-7/8	Standard ①
	2-5/16 – 3-1/4	3/4 x 1/8
	3-5/16 – 3-1/2	7/8 x 1/16
F	1 – 3-1/4	Standard ①
	3-5/16 – 3-3/4	7/8 x 3/16
	3-13/16 – 3-15/16	1 x 1/8
	4	No K.S.
J	1-7/16 – 3-13/16	Standard ①
	3-7/8 – 3-15/16	1 x 3/8
	4 – 4-1/2	1 x 1/8

① Standard Keyseat Dimension

Shaft Dia.	Width	Depth
1/2 – 9/16	1/8	1/16
5/8 – 7/8	3/16	3/32
15/16 – 1-1/4	1/4	1/8
1-5/16 – 1-3/8	5/16	5/32
1-7/16 – 1-3/4	3/8	3/16
1-13/16 – 2-1/4	1/2	1/4
2-5/16 – 2-3/4	5/8	5/16
2-13/16 – 3-1/4	3/4	3/8
3-5/16 – 3-3/4	7/8	7/16
3-13/16 – 4-1/2	1	1/2
4-9/16 – 5-1/2	1-1/4	5/8
5-9/16 – 6-1/2	1-1/2	3/4

Type SC Spacer Couplings BTS

Selection Conventional Spacer Design

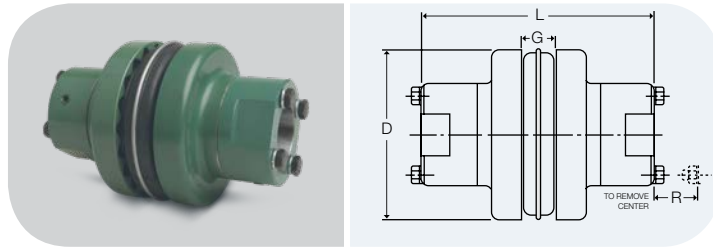

For other distances between shaft ends not shown here, please see page F1-16 or use the Coupling Selection Program at www.TBwoods.com/Select.

For dimensions of separate Type SC Spacer components, refer to page F1-15.

Coupling Size	Required Distance Between Shafts	Use Flange Number	Use Hub Number	Max Bore Std. KS	Dimensions				Weight (lbs.) ■
					D	L ⁽²⁾	G	R	
4JSC	3-1/2	4JSC35	-	1-1/8 ⁽¹⁾	2.460	5-5/8	5/8	-	2.7
5SC	3-1/2	5SC35	5SCH	1-1/8	3.250	5-5/8	3/4	9/16	4.5
6SC	3-1/2	6SC35	6SCH-6SCHS	1-3/8	4.000	5-7/8	7/8	3/4	7.3
	4-3/8	6SC44	6SCH-6SCHS	1-3/8	4.000	6-3/4	7/8	3/4	8.1
7SC	5	6SC50	6SCH-6SCHS	1-3/8	4.000	7-3/8	7/8	3/4	8.7
	3-1/2	7SC35	7SCH-7SCHS	1-5/8	4.625	6-3/8	1	5/8	9.9
	4-3/8	7SC44	7SCH-7SCHS	1-5/8	4.625	7-1/4	1	5/8	10.8
8SC	5	7SC50	7SCH-7SCHS	1-5/8	4.625	7-7/8	1	5/8	11.4
	3-1/2	8SC35	8SCH-8SCHS	1-7/8	5.450	6-7/8	1-1/8	13/16	15.2
	4-3/8	8SC44	8SCH-8SCHS	1-7/8	5.450	7-3/4	1-1/8	13/16	16.4
	5	8SC50	8SCH-8SCHS	1-7/8	5.450	8-3/8	1-1/8	1-3/16	17.4
9SC	5	8SC50-10	10SCH-10SCHS	2-3/8	5.450	9-5/8	1-1/8	1-3/16	27.2
	3-1/2	9SC35	9SCH-9SCHS	2-1/8	6.350	7-1/2	1-7/16	1-1/16	18.6
	4-3/8	9SC44	9SCH-9SCHS	2-1/8	6.350	8-1/4	1-7/16	1-1/16	22.2
	5	9SC50	9SCH-9SCHS	2-1/8	6.350	8-7/8	1-7/16	1-1/16	23.2
	7	9SC50-11	11SCH-11SCHS	2-7/8	6.350	10-3/8	1-7/16	1-3/16	40.4
10SC	7-3/4	9SC70-11	11SCH-11SCHS	2-7/8	6.350	12-3/8	1-7/16	1-3/16	48.2
	5	10SC48	10SCH-10SCHS	2-3/8	7.500	9-3/8	1-5/8	1-3/16	37.6
	7	10SC50	10SCH-10SCHS	2-3/8	7.500	9-5/8	1-5/8	1-3/16	38.4
	7-3/4	10SC70-13	13SCH-13SCHS	3-3/8	7.500	13-5/8	1-5/8	1-7/8	72.0
	10	10SC78-13	13SCH-13SCHS	3-3/8	7.500	14-3/8	1-5/8	1-7/8	76.0
	10	10SC100-13	13SCH-13SCHS	3-3/8	7.500	16-5/8	1-5/8	1-7/8	88.0
11SC	4-3/4	11SC48	11SCH-11SCHS	2-7/8	8.625	10-5/16	1-7/8	1-3/16	54.5
	5	11SC50	11SCH-11SCHS	2-7/8	8.625	10-3/8	1-7/8	1-3/16	54.7
	7	11SC70-14	14SCH	3-7/8	8.625	14-5/8	1-7/8	2	86.1
	7-3/4	11SC78-14	14SCH	3-7/8	8.625	15-3/8	1-7/8	2	90.3
	10	11SC100-14	14SCH	3-7/8	8.625	17-5/8	1-7/8	2	102.7
12SC	7	12SC70	12SCH-12SCHS	2-7/8	10.000	12-7/8	2-5/16	1-1/2	88.1
	7-3/4	12SC70-14	14SCH	3-7/8	10.000	14-5/8	2-5/16	2	99.1
	10	12SC78	12SCH-12SCHS	2-7/8	10.000	13-5/8	2-5/16	1-1/2	91.9
	7-3/4	12SC78-14	14SCH	3-7/8	10.000	15-3/8	2-5/16	2	103.3
	10	12SC100-14	14SCH	3-7/8	10.000	17-5/8	2-5/16	2	115.7
13SC	7-3/4	13SC78	13SCH-13SCHS	3-3/8	11.750	14-3/8	2-11/16	1-7/8	129.6
14SC	7-3/4	14SC78	14SCH	3-7/8	13.875	15-3/8	3-1/4	2	179.9

■ Approximate weight for completely assembled spacer coupling.

⁽¹⁾ 4JSC35 x 1-1/8 has shallow keyseat. ⁽²⁾ "L" dimension and weight will change if one or two short (HS) hubs used.

Note: Refer to page F1-15 to order — specify components separately.

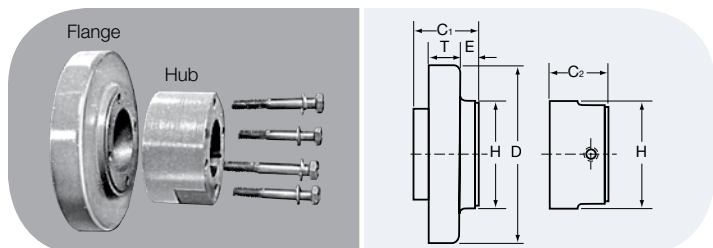

TYPE SC FLANGES AND HUBS

Tables on page F1-15 provide dimensional information for flanges and hubs used for Spacer Couplings. For assembled dimensions, see table above. Any of the sleeves shown on page F1-5 may be used.

Type SC Flanges And Hubs BTS

Selection

Conventional Spacer Design

ILLUSTRATION AND DIMENSIONAL DRAWINGS SHOWN AT BOTTOM OF PAGE F1 – 14.

Coupling Size	Flange Number	For Distance Between Shafts*	For Hub	Dimensions					Weight (lbs.) ■
				D	E	H	C ₁	T	
4JSC	4JSC35	3-1/8	①	2.460	2-1/16	2	2-1/2	7/16	1.3
5SC	5SC35	3-1/2	5SCH	3.250	51/64	2	1-11/16	19/32	1.3
6SC	6SC35	3-1/2	6SCH-6SCHS	4.000	19/32	2-1/2	1-5/8	23/32	2.0
	6SC44	4-3/8	6SCH-6SCHS	4.000	1-1/32	2-1/2	2-1/16	23/32	2.4
	6SC50	5	6SCH-6SCHS	4.000	1-11/32	2-1/2	2-3/8	23/32	2.7
7SC	7SC35	3-1/2	7SCH-7SCHS	4.625	15/32	2-13/16	1-5/8	25/32	2.5
	7SC44	4-3/8	7SCH-7SCHS	4.625	29/32	2-13/16	2-1/16	25/32	3.0
	7SC50	5	7SCH-7SCHS	4.625	1-7/32	2-13/16	2-3/8	25/32	3.3
8SC	8SC35	3-1/2	8SCH-8SCHS	5.450	9/32	3-1/4	1-5/8	29/32	3.7
	8SC35-10	3-1/2	10SCH-10SCHS	5.450	9/32	4-3/8	1-5/8	29/32	3.5
	8SC44	4-3/8	8SCH-8SCHS	5.450	23/32	3-1/4	2-1/16	29/32	4.3
	8SC50	5	8SCH-8SCHS	5.450	1-1/32	3-1/4	2-3/8	29/32	4.8
	8SC50-10	5	10SCH-10SCHS	5.450	1-1/32	4-3/8	2-3/8	29/32	5.5
9SC	9SC35	3-1/2	9SCH-9SCHS	6.350	1/16	3-5/8	1-11/16	1-1/32	4.1
	9SC44	4-3/8	9SCH-9SCHS	6.350	7/16	3-5/8	2-1/16	1-1/32	5.9
	9SC50	5	9SCH-9SCHS	6.350	3/4	3-5/8	2-3/8	1-1/32	6.4
	9SC50-11	5	11SCH-11SCHS	6.350	3/4	5-1/4	2-3/8	1-1/32	7.0
	9SC70-11	7	11SCH-11SCHS	6.350	1-3/4	5-1/4	3-3/8	1-1/32	10.9
	9SC78-11	7-3/4	11SCH-11SCHS	6.350	2-1/8	5-1/4	3-3/4	1-1/32	12.3
10SC	10SC48	4-3/4	10SCH-10SCHS	7.500	11/32	4-3/8	2-1/4	1-7/32	9.8
	10SC50	5	10SCH-10SCHS	7.500	15/32	4-3/8	2-3/8	1-7/32	10.2
	10SC70-13	7	13SCH-13SCHS	7.500	1-15/32	6-1/8	3-3/8	1-7/32	14.5
	10SC78-13	7-3/4	13SCH-13SCHS	7.500	1-27/32	6-1/8	3-3/4	1-7/32	16.5
	10SC100-13	10	13SCH-13SCHS	7.500	2-31/32	6-1/8	4-7/8	1-7/32	22.5
11SC	11SC48	4-3/4	11SCH-11SCHS	8.625	1/32	5-1/4	1-1/2	1-1/2	12.5
	11SC50	5	11SCH-11SCHS	8.625	1/16	5-1/4	1-9/16	1-1/2	12.6
	11SC70-14	7	14SCH	8.625	1-1/16	6-1/2	2-9/16	1-1/2	16.3
	11SC78-14	7-3/4	14SCH	8.625	1-7/16	6-1/2	2-15/16	1-1/2	18.4
	11SC100-14	10	14SCH	8.625	2-9/16	6-1/2	4-1/16	1-1/2	24.6
12SC	12SC70	7	12SCH-12SCHS	10.000	21/32	5-3/4	2-15/32	1-11/16	23.4
	12SC70-14	7	14SCH	10.000	21/32	6-1/2	2-15/32	1-11/16	21.3
	12SC78	7-3/4	12SCH-12SCHS	10.000	1-1/32	5-3/4	2-27/32	1-11/16	25.3
	12SC78-14	7-3/4	14SCH	10.000	1-1/32	6-1/2	2-27/32	1-11/16	23.4
	12SC100-14	10	14SCH	10.000	2-5/32	6-1/2	3-31/32	1-11/16	29.6
13SC	13SC78	7-3/4	13SCH-13SCHS	11.750	9/16	6-1/8	3-1/4	1-31/32	38.4
14SC	14SC78	7-3/4	14SCH	13.875	1/32	6-1/2	2-23/32	2-1/4	55.2

* Flanges can be mixed to form different Between-Shaft Dimensions. See chart page F1 – 16. ■ Approximate weight for each flange.

Coupling Size	Hub Number	Max Bore	STOCK BORES *		Dimensions			Weight (lbs.) ■
			Plain Bore	Bore with Standard Keyseat & Set Screw	C ₂	H	Cap Screws Furnished	
4JSC	①	1-1/8	-	5/8 – 7/8 – 1 – 1-1/8* ①	1-1/16	2	-	-
5SC	5SCH	1-1/8	1/2	5/8 – 3/4 – 7/8 – 1 – 1-1/8	1-3/32	2	4 – 10 x 1-1/2	.8
6SC	6SCH	1-3/8	5/8	3/4 – 7/8 – 1 – 1-1/8 – 1-1/4 – 1-3/8	1-7/32	2-1/2	4 – 1/4 x 1-3/4	1.4
	6SCHS	7/8	-	7/8	31/32	2-1/2	4 – 1/4 x 1-1/2	1.1
7SC	7SCH	1-5/8	5/8	7/8 – 1 – 1-1/8 – 1-3/8 – 1-1/2 – 1-5/8	1-15/32	2-13/16	4 – 1/4 x 1-7/8	2.0
	7SCHS	7/8	-	7/8	1-3/32	2-13/16	4 – 1/4 x 1-1/2	1.5
8SC	8SCH	1-7/8	3/4	7/8 – 1 – 1-1/8 – 1-3/8 – 1-1/2 – 1-5/8 – 1-3/4 – 1-7/8	1-23/32	3-1/4	4 – 5/16 x 2-1/4	3.2
	8SCHS	7/8	-	7/8	1-7/32	3-1/4	4 – 5/16 x 1-3/4	2.0
9SC	9SCH	2-1/8	7/8	1 – 1-1/8 – 1-3/8 – 1-1/2 – 1-5/8 – 1-3/4 – 1-7/8 – 2-1/8	1-31/32	3-5/8	4 – 3/8 x 2-3/4	4.2
	9SCHS	1-1/2	-	1-1/8	1-17/32	3-5/8	4 – 3/8 x 2-1/4	3.7
10SC	10SCH	2-3/8	1-1/8	1-5/8 – 1-7/8 – 2-1/8 – 2-3/8	2-11/32	4-3/8	4 – 7/16 x 3-1/4	7.4
	10SCHS	1-5/8	-	1-1/8	1-21/32	4-3/8	4 – 7/16 x 2-1/2	5.5
11SC	11SCH	2-7/8	1-1/8	1-7/8 – 2-1/8 – 2-3/8 – 2-7/8	2-23/32	5-1/4	4 – 1/2 x 3-1/2	12.2
	11SCHS	1-7/8	-	1-1/8 – 1-5/8	1-29/32	5-1/4	4 – 1/2 x 2-3/4	9.3
12SC	12SCH	2-7/8	1-3/8	2-1/8 – 2-3/8 – 2-7/8	2-31/32	5-3/4	4 – 5/8 x 4	16.6
	12SCHS	2-1/2	-	2-3/8	2-17/32	5-3/4	4 – 5/8 x 3-1/2	14.1
13SC	13SCH	3-3/8	1-3/8	2-3/8 – 2-7/8 – 3-3/8	3-11/32	6-1/8	4 – 5/8 x 4-1/2	19.9
	13SCHS	2-1/2	-	2-1/8 – 2-3/8	2-15/32	6-1/8	4 – 5/8 x 3-1/2	16.0
14SC	14SCH	3-7/8	1-5/8	2-3/8 – 2-7/8 – 3-3/8 – 3-7/8	3-27/32	6-1/2	4 – 5/8 x 5	24.2

① FOR 4JSC the hub is an integral part of the flange. 4JSC x 1-1/8 has 1/4 x 1/16 shallow keyseat.

* See page F1 – 10 for bore tolerances and page F1 – 13 for standard keyseat dimensions.

② If using 10SCHS hub, 7/16-14NC x 2-1/4 long capscrew needed (not furnished).

■ Approximate weight for each hub.

Between Shaft Spacings

Selection

Spacer couplings are available for most popular Distance Between Shaft Ends (DBSE) dimensions. Other spacings can be achieved by mixing flanges.

The “Standard” column provides spacings using identical flanges; the “Combination” column mixes flanges; the column headed “Semi-Spacer” uses one flange that is not made for spacer coupling applications and thus does not have a detachable hub.

To select couplings for various DBSEs, please see our Coupling Selector Program at www.TBWoods.com/Select

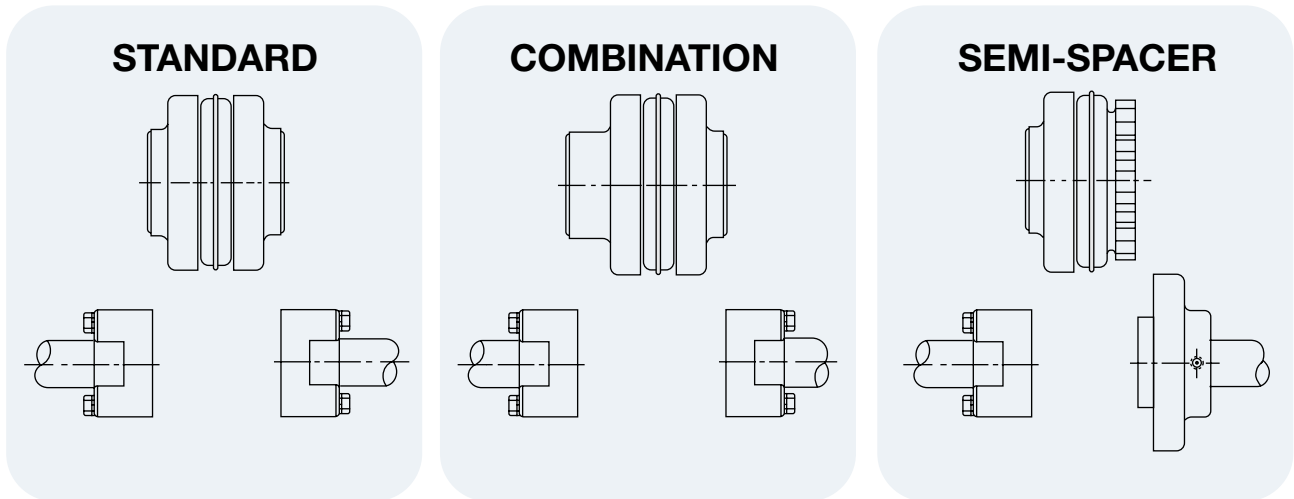

STANDARD	
Spacing	Use Flanges*
3-1/2	2(-) SC35
4-3/8	2(-) SC44
5	2(-) SC50
7	2(-) SC70
7-3/4	2(-) SC78
10	2(-) SC100

COMBINATION	
Spacing	Use Flanges*
3-15/16	SC35 & SC44
4-1/4	SC35 & SC50
4-11/16	SC44 & SC50
5-1/4	SC35 & SC70
5-5/8	SC35 & SC78
5-11/16	SC44 & SC70
6	SC50 & SC70
6-1/16	SC44 & SC78
6-3/8	SC50 & SC78
6-3/4	SC35 & SC100**
7-3/16	SC44 & SC100**
7-3/8	SC70 & SC78
7-1/2	SC50 & SC100
8-1/2	SC70 & SC100
8-7/8	SC78 & SC100

SEMI-SPACER	
Spacing	Use Flanges*
1-7/8	S & SC35
2-5/16	S & SC44
2-5/8	S & SC50
3-5/8	S & SC70
4	S & SC78
5-1/8	S & SC100

* Check individual coupling size for flange availability.

** Non-Stock

Note: Other combinations available — consult factory or see www.TBWoods.com/Select

Selection Dimensions

CLAMP HUB – SPACER DESIGN

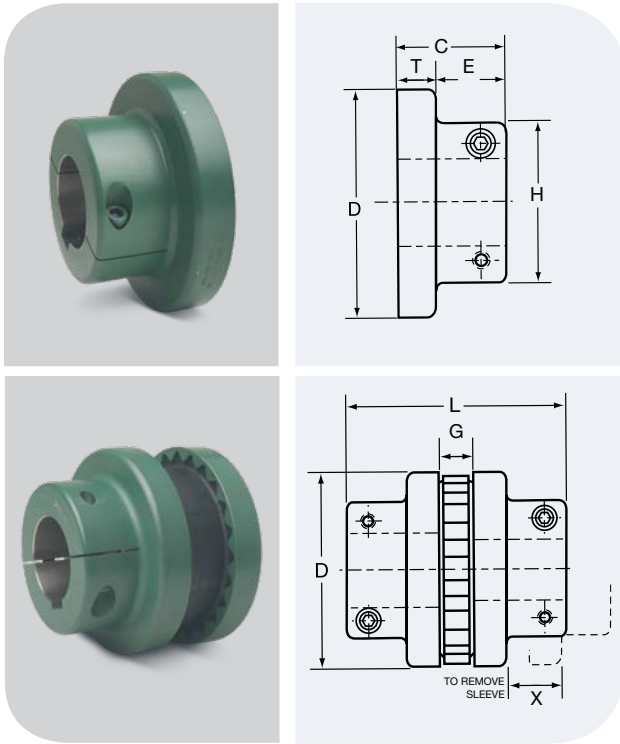

FLANGES

Sure-Flex Plus® Type C Clamp Hub flanges employ integral locking collars and screws to assure a secure shaft connection without marring the shaft surface. One setscrew is furnished over the key. The clamp hub flange is often used in applications that require easy seal replacement on equipment using face seals, as the clamp hub eliminates the need for a second set screw at 90 degrees from the key.

COUPLINGS

Type C Clamp Hub Couplings can use all sleeve types shown on page F1-5. Type C couplings may often be used where spacer couplings are required.

Spacing between internal flange hubs equals G.

To order complete couplings, specify coupling size with flange symbol (C), giving bore required. Refer to page F1-3 to order the required coupling.

DIMENSIONS (in.)

Flange Size	Stock Bores	Min Bore	Maximum Bore		Distance Between Shafts		Dimensions							Weight (lbs.)*
			Standard Keyseat	Shallow Keyseat	Min	Max	C	D	E	G	H	L	X	
6C	1-1/8, 1-7/8, 40mm	7/8	1-5/8	1-7/8	2	2-3/4	1-15/16	4.000	1.16	7/8	3	4-3/4	1	2.6
7C	1-3/8, 1-7/8, 35mm, 40mm	1-1/8	1-7/8		2-5/16	3-7/16	2-3/16	4.625	1.41	1-1/16	3-1/4	5-7/16	1-3/16	3.6
8C	1-3/8, 1-5/8, 1-3/4, 1-7/8, 2-1/8, 2-1/4, 2-3/8, 40mm	1-3/8	2-1/4	2-3/8	2-9/16	4	2-1/2	5.450	1.59	1-1/8	3-7/8	6-1/8	1-3/8	6.5
9C	1-5/8, 1-3/4, 1-7/8, 2, 2-1/8, 2-1/4, 2-3/8, 2-1/2	1-5/8	2-1/2	2-11/16	3-1/16	4-5/8	3	6.350	1.97	1-7/16	4-1/4	7-7/16	1-9/16	9.8
10C	1-5/8, 1-7/8, 2-1/4, 2-3/8, 2-1/2	1-5/8	2-7/8		3-9/16	5-1/4	3-1/2	7.500	2.28	1-11/16	5	8-11/16	1-13/16	16.6
11C	2-1/8, 2-3/8, 2-1/2	1-7/8	3-3/8		4-1/8	5-7/8	4	8.625	2.5	1-7/8	5-3/8	9-7/8	2-1/8	26.0
12C	2-1/8	1-7/8	3-3/8		4-7/8	6-1/2	4-3/8	10.000	2.69	2-3/8	6	11-1/8	2-3/8	38.3

For Standard keyseat dimensions, see chart page F1-13. * Approximate weight of one flange.

Bore Tolerances for Type C Flanges

These bores provide a slip fit.

Bore (in.)	Tolerance (in.)
Up to and including 2"	+0.0005 to +0.0015
Over 2"	+0.0005 to +0.0020

Shallow Keyseat Dimensions

Some large bore Type C flanges are supplied with shallow keyseats. In these cases, a rectangular key is furnished. The flanges and bores involved are as follows:

Size	Bore Range	KS	Key Furnished
6C	1- 11 /16 to 1 -7/8	1/2 X 1/16	1/2 x 5/16 x 1-7/8
8C	2-5/16 to 2 -3/8	5/8 x 1/16	5/8 x 3/8 x 2-1/ 2
9C	2-7/16 to 2-11/16	5/8 x 3/16	5/8 x 1/2 x 3

Sure-Flex Plus® Couplings

Installation Instructions

Installation Instructions

Sure-Flex Plus flanges (outer metallic parts) and sleeves (inner elastomeric elements) come in many sizes and types. First, determine the size and type of components being used. Check maximum RPM values in the table below against operating speed. Remove all components from their boxes, and loosely assemble the coupling on any convenient surface. ((If using a two-piece E or N sleeve, do not install the wire ring at this time.)

- 1 Inspect all coupling components and remove any protective coatings or lubricants from bores, mating surfaces and fasteners. Remove any existing burrs, etc. from the shafts.
- 2 Slide one coupling flange onto each shaft using keys where required. When using Type B flanges, follow the instructions furnished with the Sure-Grip bushings.
- 3 Position the flanges on the shafts to approximately achieve the G_1 dimension shown in the table. It is usually best to have an equal length of shaft extending into each flange. Move one flange to its final position. Torque fasteners to proper values. Slide the other flange far enough away to install the sleeve. With a two-piece sleeve, do not move the wire ring to its final position; allow it to hang loosely in the groove adjacent to the teeth.

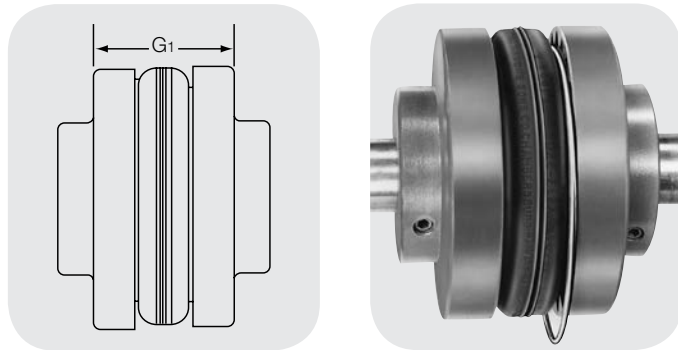

4 Slide the loose flange on the shaft until the sleeve is completely seated in the teeth of each flange. (The " G_1 " dimension is for reference and not critical.) Secure the flange to the shaft. Different coupling sleeves require different degrees of alignment precision. Locate the alignment values for your sleeve size and type in the table.

5 Check parallel alignment by placing a straight-edge across the two coupling flanges and measuring the maximum offset at various points around the periphery of the coupling without rotating the coupling. If the maximum offset exceeds the figure shown under "Parallel" in the table, realign the shafts.

6 Check angular alignment with a caliper. Measure from the outside of one flange to the outside of the other at intervals around the periphery of the coupling. Determine the maximum and minimum dimensions without rotating the coupling. The difference between the maximum and minimum must not exceed the figure given under "Angular" in the table. If a correction is necessary, be sure to recheck the parallel alignment.

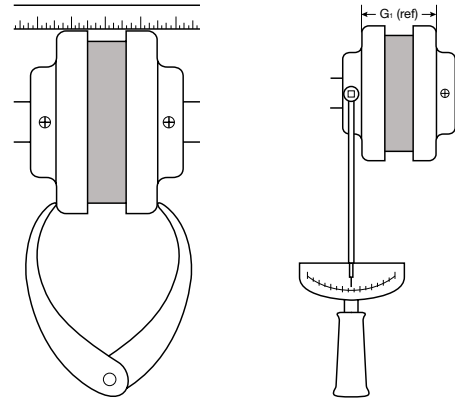

MAXIMUM RPM AND ALLOWABLE MISALIGNMENT (Dimensions in inches)						
Sleeve Size	Maximum RPM	G_1 (ref)	Types JE, JN, JES, JNS, E & N		*Type H, HS, Urethane	
			Parallel	Angular	Parallel	Angular
3	9200	1.2	.010	.035		
4	7600	1.5	.010	.043		
5	7600	1.9	.015	.056		
6	6000	2.4	.015	.070	.010	.016
7	5250	2.6	.020	.081	.012	.020
8	4500	2.9	.020	.094	.015	.025
9	3750	3.5	.025	.109	.017	.028
10	3600	4.1	.025	.128	.020	.032
11	3600	4.9	.032	.151	.022	.037
12	2800	5.7	.032	.175	.025	.042
13	2400	6.7	.040	.195	.030	.050
14	2200	7.8	.045	.242	.035	.060
16	1500	10.3	.062	.330		

Note: When using a VFD with a centrifugal pump or fan, reduce the above values by 1/2.

***Type H and HS sleeves should never be used as direct replacements for EPDM or Neoprene sleeves.**

7 If the coupling employs the two-piece sleeve with wire ring, move the ring into its groove in the center of the sleeve. If necessary, use soapy water and lever the ring with a blunt tool.

8 Install coupling guards per OSHA requirements.

CAUTION: Coupling sleeves may be thrown from the coupling assembly with substantial force if subjected to a severe shock load.

Dura-Flex® Couplings

F2



Patent No. 5,611,732

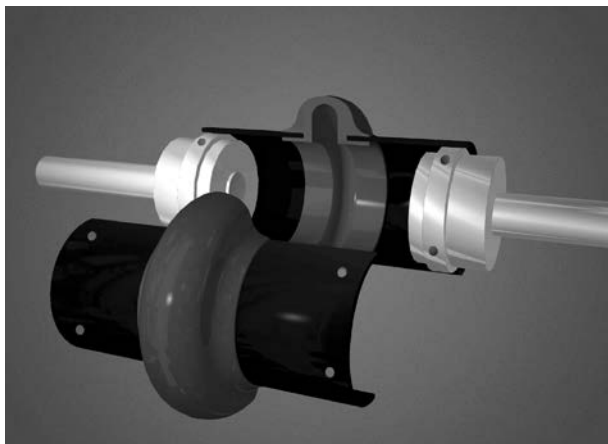

The specially designed split-in-half element can be easily replaced without moving any connected equipment.

FEATURES

- Designed from the ground up using finite element analysis to maximize flex life.
- Easy two piece element installation. No need to move the hubs during replacement.
- One spacer size to handle most different between shaft spacings.
- Light weight element absorbs shock loading and torsional vibration.
- Same hubs used on both spacer and standard elements.
- No lubrication.
- Good chemical resistance.
- Stock bore-to-size (BTS), Sure-Grip bushed (QD) and Taper-Lock® bushed (TL) Hubs.

® Taper-Lock is a registered trade name of Rockwell Automation-Dodge.

Dura-Flex® Coupling

Selection

A. Determine the Prime Mover Classification

Prime Mover	Class
• Electric Motors (Standard duty), Hydraulic Motors, Turbines	A
• Gasoline or Steam Engines (4 or more cylinders)	B
• Diesel or Gas Engines, High Torque Electric Motors	C

B. Determine the Load Characteristics and the Service Factor

Typical Applications	Load	Characteristics	Prime Mover Class		
			A	B	C
Agitators (pure liquids), Blowers (centrifugal), Can and Bottle Filling Machines, Conveyors - uniformly loaded or fed (belt, chain, screw), Fans (centrifugal), Generators (uniform load), Pumps (centrifugal), Screens (air washing, water), Stokers (uniform load), Woodworking Machines (planers, routers, saws)	Uniform	Even loads - no shock - non reversing - infrequent starts (up to 10 per hour) - low starting torques	1.0	1.5	2.0
Beaters, Blowers (lobe, vane), Compressors (centrifugal, rotary), Conveyors - non uniformly loaded or fed (belt, bucket, chain, screw), Dredge Pumps, Fans (forced draft, propeller), Kilns, Paper Mills (calendars, converting machines, conveyors, dryers, mixers, winders), Printing Presses, Pumps (gear, rotary), Shredders, Textile Machinery (dryers, dyers)	Moderate shock	Uneven loads – moderate shock – infrequent reversing – moderate torques	1.5	2.0	2.5
Cranes (bridge, hoist, trolley), Fans (cooling tower), Generators (welding), Hammer Mills, Mills (ball, pebble, rolling, tube, tumbling), Pumps (oil well), Wire Drawing Machines	Heavy shock	Uneven loads - heavy shock - frequent starts and stops - high starting torques -high inertia peak loads	2.0	2.5	3.0

Note: The above applications depict the generally accepted conditions encountered in industry. Conditions subject to extreme temperatures, abrasive dusts, corrosive liquids, excessively high starting torques, etc., must be considered as extra heavy shock loads. These conditions will increase service factors. Consult TB Wood's for these selections.

C. Calculate Design Horsepower or Design Torque

- If Prime Mover is a 1160, 1750, or 3500 rpm motor.
Design Hp = Prime Mover HP x Service Factor
Go to page F2—3 and reference the corresponding motor rpm column.
- If Prime Mover is not one of the three speeds listed above.
Design HP @ 100 rpm = (Primer Mover Hp x Service Factor x 100) / Coupling RPM
Go to page F2—3 and reference HP @ 100 RPM column.
- If Using Prime Mover Torque
Design Torque = Prime Mover Torque x Service Factor
Go to page F2—3 and reference Torque column.

D. Select Coupling (DURA-FLEX Couplings are sold by component)

A DURA-FLEX Assembly consists of one element (STD or Spacer) and two hubs (BTS or QD). Optional high speed rings may also be ordered for spacer elements. Below is an ordering example for Dura-Flex Couplings.

	Part #	Description	Size 20 Example
Element (1)	WE2 - WE80	Standard element, sizes 2 through 80	WE20
	WES2 - WES80	Spacer element, sizes 2 through 80	WES20
Hubs (2)	WE[2-80] x Bore	BTS hubs - stock bore (specify bore size)	WE20H138
	WE[4-80] - Bushing	QD hubs (sizes 4 through 80, bushing not included)	WE20H
	WE[3-80] - TL Bushing	TL hubs (sizes 3 through 80, bushing not included)	WE20HTL
HS Rings (1)	WE[20-80]R	High speed rings - sizes 20-80 (standard for sizes 2-10)	WE20R

COUPLING RATINGS (STD & SPACER)

Coupling Size	HP@RPM				Torque (IN LBS)	Stiffness in lbs/Radian	Maximum RPM		Max. Misalignment	
	100	1160	1750	3500			Standard	Spacer	Parallel	Angular
WE2	.30	3.5	5.3	11	190	3170	7500	7500	1/16	4°
WE3	.58	6.7	10	20	365	4710	7500	7500	1/16	4°
WE4	.88	10	15	31	550	5370	7500	7500	1/16	4°
WE5	1.5	17	26	51	925	9820	7500	7500	1/16	4°
WE10	2.3	27	40	81	1450	15800	7500	7500	1/16	4°
WE20	3.7	42	64	128	2300	27600	6600	4800	3/32	3°
WE30	5.8	67	101	203	3650	42200	5800	4200	3-32	3°
WE40	8.9	101	153	305	5500	65200	5000	3600	3/32	3°
WE50	12	141	212	425	7650	123000	4200	3100	3-32	3°
WE60	20	230	347	694	12500	167000	3800	2800	1/8	2°
WE70	35	407	615	1229	22125	205000	3600	2600	1/8	2°
WE80	63	727	1097	2195	39500	305000	2000	1800	1/8	2°

*Maximum spacer RPM = Maximum standard RPM if using optional high speed rings. Operating temperature range is -40 F to 200 F.

BTS HUBS - STOCK BORES

Bore Size	Bore Designation*	WE2H	WE3H	WE4H	WE5H	WE10H	WE20H	WE30H	WE40H	WE50H	WE60H	WE70H	WE80H
1/2	12	OS	OS										
5/8	58	X	X	OSX									
3/4	34	XS	XS		OS								
7/8	78	XS	XS	XS	X	OS	OS						
15/16	15/16			X									
1	1	XS	XS	XS	X	X	X	OS	OS				
1-1/16	1116				X								
1-1/8	118	XS	XS	XS	XS	XS	XS	X		O	O		
1-3/16	1316			X	X								
1-1/4	114		XS	X	X	X	XS						
1-5/16	1516			X	X								
1-3/8	138		XS	XS	XS	XS	XS	XS				O	
1-7/16	1716			X	X	X							
1-1/2	112			X	X	X	XS	XS	XS				
1-9/16	1916			X									
1-5/8	158			XS	XS	XS	XS	XS	XS				
1-11/16	11116			X	X	X	X	X					
1-3/4	134				X	X	XS	XS	XS	X			
1-7/8	178				XS	XS	XS	XS	XS	X			O
1-15/16	11516					X	X						
2	2					S	X	XS					
2-1/8	218					X	XS	XS	X	X	X		
2-3/16	2316						X						
2-1/4	214						XS	XS	X	X			
2-3/8	238						XS	XS	XS	X	X	X	
2-1/2	212							XS	X				
2-5/8	258											X	
2-3/4	234							XS	XS				
2-7/8	278							XS	XS	X	X	X	X
3-3/8	338								XS	X	X	X	X
3-3/4	334												X
3-7/8	378										X	X	X
4	4										X		
4-3/8	438											X	
4-7/8	478												X
MAX BORE		1-1/8	1-3/8	1-11/16	1-7/8	2-1/8	2-3/8	2-7/8	3-3/8	3-5/8	4	4-1/2	6

O NO KEYSEAT

X STANDARD KEYSEAT

S STEEL HUB OPTION

MAX. BORE INCLUDES STANDARD KEYSEAT

* **PRODUCT NUMBER EXAMPLE** → WE5H114 for WE5 x 1-1/4 HUB
WE5HS118 for WE5 x 1-1/8 STEEL HUB

BORE TOLERANCES (BTS)

BORE SIZE	TOLERANCE
UP TO AND INCLUDING 2"	+ .0005 to + .0015
OVER 2"	+ .0005 to + .0020

Dura-Flex® BTS Couplings

Dimensions

Assembly Dimensions for BTS Couplings.

(All dimensions in inches) Minimum Shaft Spacing = .25"

Dimensions Common to BTS Standard and Spacer Assemblies

SIZE	A	B	C	Max. Bore
WE2 & WES2	3.70	1.85	0.94	1-1/8
WE3 & WES3	4.24	2.32	1.50	1-3/8
WE4 & WES4	4.52	2.60	1.69	1-11/16
WE5 & WES5	5.40	3.13	1.75	1-7/8
WE10 & WES10	6.48	3.65	1.88	2-1/8
WE20 & WES20	7.36	4.48	2.06	2-3/8
WE30 & WES30	8.41	5.42	2.31	2-7/8
WE40 & WES40	9.71	6.63	2.50	3-3/8
WE50 & WES50	11.34	8.13	2.75	3-5/8
WE60 & WES60	12.53	8.75	3.25	4
WE70 & WES70	14.00	9.25	3.62	4-1/2
WE80 & WES80	16.00	11.30	4.98	6

Standard Element Assembly

Product No.*	OAL MAX	OAL MIN	Maximum DBSE	Weight lbs.
WE2	3.78	3.22	1.90	1.5
WE3	4.32	3.80	1.32	3.3
WE4	4.68	3.82	1.30	4.4
WE5	5.30	4.32	1.80	7.4
WE10	5.57	4.33	1.81	11.2
WE20	6.82	4.62	2.70	16.3
WE30	7.61	5.19	2.99	27.7
WE40	8.16	5.56	3.16	45.4
WE50	9.21	6.13	3.71	59.0
WE60	10.70	7.20	4.20	82.6
WE70	11.88	8.24	4.64	109
WE80	16.60	10.48	6.64	242

* Product number is element only.

Spacer Element Assembly

Product No.*	OAL MAX	OAL MIN	Maximum DBSE	Weight lbs.
WES2	5.92	5.72	4.04	2.5
WES3	8.02	7.50	5.02	4.8
WES4	8.38	7.52	5.00	6.1
WES5	8.50	7.52	5.00	9.4
WES10	8.76	7.52	5.00	13.6
WES20	11.17	9.35	7.05	19.2
WES30	11.65	9.35	7.03	31.0
WES40	11.89	9.35	6.89	48.9
WES50	12.31	9.35	6.81	63.5
WES60	16.28	12.78	9.78	91.0
WES70	16.81	13.17	9.57	128
WES80	19.73	13.61	9.77	258

* Product number is element only.

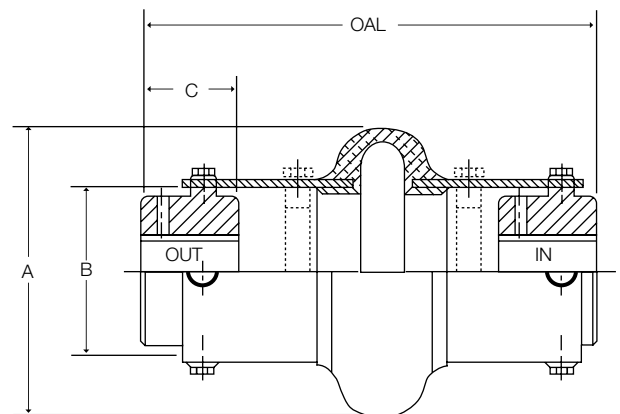
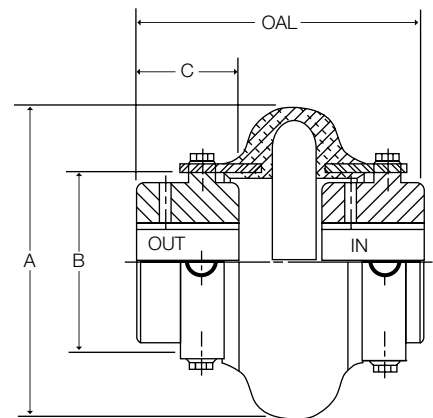

Sizes WES2 through WES10 are furnished with high speed rings. All larger sizes, rings can be ordered as an option.

All weights shown are with MPB style hubs.

Shaft Spacing from 1/4" up to the MAX DBSE can be accommodated by positioning hubs IN or OUT or by using various existing hole patterns.
OAL - Over All Length does not include bolt heads

Dura-Flex® QD Bushed Couplings

Dimensions

Assembly Dimensions for QD Bushed Couplings.

(All dimensions in inches) Minimum Shaft Spacing = .25"

Dimensions Common to QD Bushed Standard and Spacer Assemblies

SIZE	A	B	D	Bushing	Max. Bore
WE4 & WES4	4.52	2.60	1.00	JA	1-1/4
WE5 & WES5	5.40	3.13	1.25	SH	1-11/16
WE10 & WES10	6.48	3.65	1.31	SDS	2
WE20 & WES20	7.36	4.48	1.88	SK	2-5/8
WE30 & WES30	8.41	5.42	2.00	SF	2-15/16
WE40 & WES40	9.71	6.63	2.63	E	3-1/2
WE50 & WES50	11.34	8.13	2.63	E	3-1/2
WE60 & WES60	12.53	8.75	3.63	F	4
WE70 & WES70	14.00	9.25	4.50	J	4-1/2
WE80 & WES80	16.00	11.3	6.75	M	5-1/2

Standard Element Assembly

Product No.*	OAL MAX	OAL MIN	Maximum DBSE	Weight lbs.
WE4	3.88	3.24	1.88	3.8
WE5	4.50	4.24	2.00	6.0
WE10	5.07	3.83	2.45	8.8
WE20	6.62	4.38	2.86	15.9
WE30	6.19	5.43	2.19	25.1
WE40	7.00	6.50	1.74	47.0
WE50	8.13	6.61	2.87	48.0
WE60	9.00	8.68	1.74	79.4
WE70	10.86	10.12	1.86	124
WE80	15.10	13.97	1.60	268

* Product number is element only.

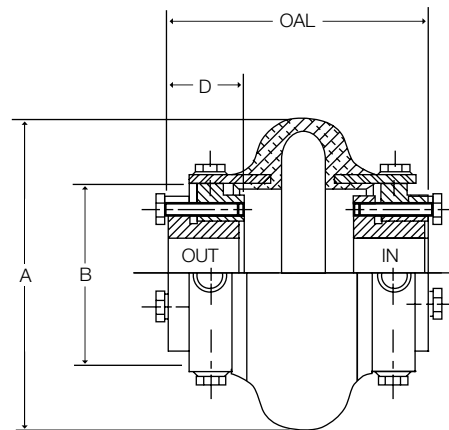

Spacer Element Assembly

Product No.*	OAL MAX	OAL MIN	Maximum DBSE	Weight lbs.
WES4	7.58	7.28	5.58	5.5
WES5	7.70	7.44	5.20	8.0
WES10	8.26	7.28	5.64	11.2
WES20	10.97	9.35	7.21	18.8
WES30	10.23	9.47	6.23	28.4
WES40	10.73	10.23	5.47	50.5
WES50	11.23	9.71	5.99	52.5
WES60	14.58	14.34	7.32	107
WES70	15.79	15.05	6.79	143
WES80	18.23	17.11	4.73	284

* Product number is element only.

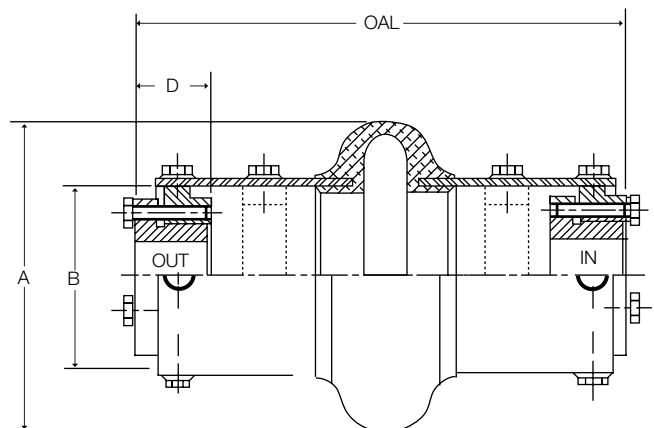

Sizes WES4 through WES10 are furnished with high speed rings. All larger sizes, rings can be ordered as an option.

All weights shown are with MPB bushings.

Shaft Spacing from 1/4" up to the MAX DBSE can be accommodated by positioning hubs IN or OUT or by using various existing hole patterns.

OAL - Over All Length does not include bolt heads

Dura-Flex® Taper-Lock® Bushed Couplings

Dimensions

Assembly Dimensions for Taper-Lock® Bushed Couplings.

(All dimensions in inches) Minimum Shaft Spacing = .25"

Dimensions Common to Taper-Lock® Bushed Standard and Spacer Assemblies

SIZE	A	B	H	Bushing	Max. Bore
WE3 & WES3	4.24	2.32	0.88	TL1008	1
WE4 & WES4	4.52	2.60	0.88	TL1008	1
WE5 & WES5	5.40	3.13	0.88	TL1108	1-1/8
WE10 & WES10	6.48	3.65	1.00	TL1310	1-7/16
WE20 & WES20	7.36	4.48	1.00	TL1610	1-11/16
WE30 & WES30	8.41	5.42	1.25	TL2012	2-1/8
WE40 & WES40	9.71	6.63	1.75	TL2517	2-11/16
WE50 & WES50	11.34	8.13	1.75	TL2517	2-11/16
WE60 & WES60	12.53	8.75	2.00	TL3020	3-1/4
WE70 & WES70	14.00	9.25	3.50	TL3535	3-15/16
WE80 & WES80	16.00	11.3	4.00	TL4040	4-7/16

Standard Element Assembly

Product No.*	OAL	Maximum DBSE	Weight lbs.
WE3	3.44	1.68	1.8
WE4	3.44	1.68	2.6
WE5	3.94	2.18	4.0
WE10	4.07	2.07	6.0
WE20	4.50	2.50	9.0
WE30	5.07	2.57	13.6
WE40	5.88	2.38	21.8
WE50	6.51	3.01	31.5
WE60	7.32	3.32	46.6
WE70	9.42	2.42	66.7
WE80	11.72	3.72	82.0

* Product number is element only.

Spacer Element Assembly

Product No.*	OAL MAX	OAL MIN	Maximum DBSE	Weight lbs.
WES3	7.14	7.28	5.38	3.2
WES4	7.14	7.28	5.38	4.2
WES5	7.14	7.28	5.38	6.0
WES10	7.26	7.28	5.26	7.9
WES20	8.85	9.35	6.85	11.9
WES30	9.11	9.35	6.61	18.0
WES40	9.61	9.61	6.11	26.8
WES50	9.61	9.61	6.11	37.4
WES60	12.90	12.90	8.90	60.7
WES70	14.35	14.35	7.35	81.4
WES80	14.85	14.35	6.85	93.2

* Product number is element only.

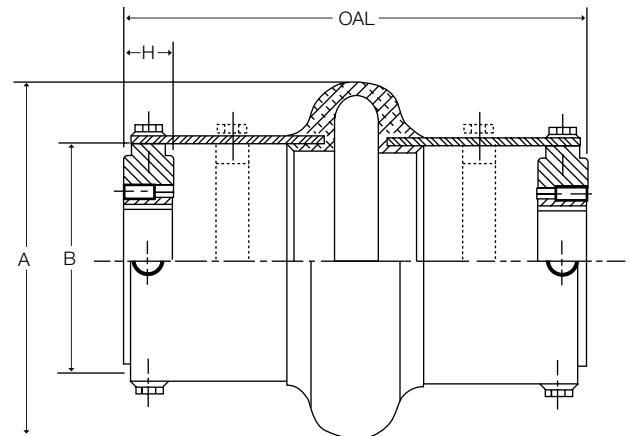
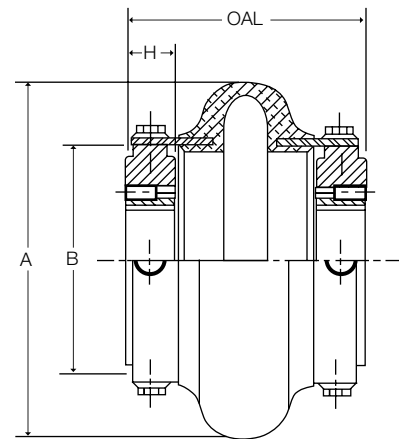

Sizes WES3 through WES10 are furnished with high speed rings. All larger sizes, rings can be ordered as an option.

All weights shown are with MPB bushings.

©Taper-Lock is a registered trade name of Rockwell Automation-Dodge.



Patent No. 5,611,732

FEATURES

- Metric Hardware
- Designed from the ground up using finite element analysis to maximize flex life.
- Easy two piece element installation. No need to move the hubs during replacement.
- One spacer size to handle most different between shaft spacings.
- Light weight element absorbs shock loading and torsional vibration.
- Same hubs used on both spacer and standard elements.
- No lubrication.
- Good chemical resistance.

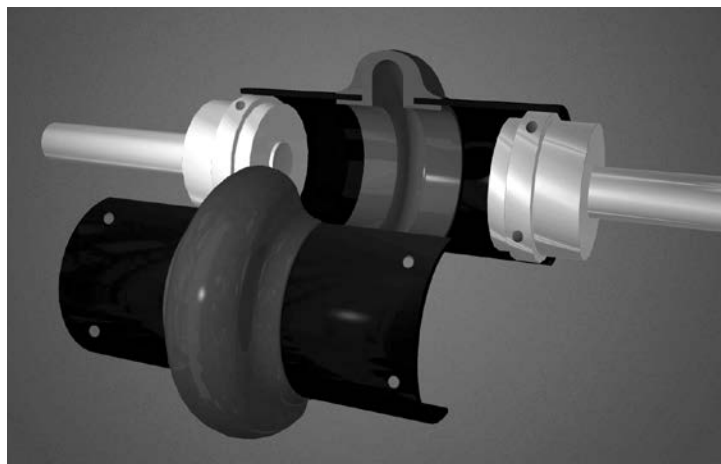

The specially designed split-in-half element can be easily replaced without moving any connected equipment.

Dura-Flex® Metric Couplings

Dimensions

A. Determine the Prime Mover Classification

Prime Mover	Class
• Electric Motors (Standard duty), Hydraulic Motors, Turbines	A
• Gasoline or Steam Engines (4 or more cylinders)	B
• Diesel or Gas Engines, High Torque Electric Motors	C

B. Determine the Load Characteristics and the Service Factor

Typical Applications	Load	Characteristics	Prime Mover Class		
			A	B	C
Agitators (pure liquids), Blowers (centrifugal, Can and Bottle Filling Machines, Conveyors - uniformly loaded or fed (belt, chain, screw), Fans (centrifugal), Generators (uniform load), Pumps (centrifugal), Screens (air washing, water), Stokers (uniform load), Woodworking Machines (planers, routers, saws)	Uniform	Even loads - no shock - non reversing - infrequent starts (up to 10 per hour) - low starting torques	1.0	1.5	2.0
Beaters, Blowers (lobe, vane), Compressors (centrifugal, rotary), Conveyors - non uniformly loaded or fed (belt, bucket, chain, screw), Dredge Pumps, Fans (forced draft, propeller), Kilns, Paper Mills (calendars, converting machines, conveyors, dryers, mixers, winders), Printing Presses, Pumps (gear, rotary), Shredders, Textile Machinery (dryers, dyers)	Moderate shock	Uneven loads - moderate shock Infrequent reversing-moderate torques	1.5	2.0	2.5
Cranes (bridge, hoist, trolley), Fans (cooling tower), Generators (welding), Hammer Mills, Mills (ball, pebble, rolling, tube, tumbling), Pumps (oil well), Wire Drawing Machines	Heavy shock	Uneven loads - heavy shock - frequent starts and stops - high starting torques - high inertia peak loads	2.0	2.5	3.0

Note: The above applications depict the generally accepted conditions encountered in industry. Conditions subject to extreme temperatures, abrasive dusts, corrosive liquids, excessively high starting torques, etc., must be considered as extra heavy shock loads. These conditions will increase service factors. Consult TB Wood's for these selections.

C. Calculate Design Horsepower or Design Torque

- If Prime Mover is a 970, 1450, or 3000 rpm motor.
Design KW = Prime Mover KW x Service Factor
Go to page F2—9 and reference the corresponding motor rpm column.
- If Prime Mover is not one of the three speeds listed above.
Design KW @ 100 rpm = (Prime Mover KW x Service Factor x 100) / Coupling RPM
Go to page F2—9 and reference KW @ 100 RPM column.
- If Using Prime Mover Torque
Design Torque = Prime Mover Torque x Service Factor
Go to page F2—9 and reference Torque column.

Dimensions

D. DURA-FLEX Couplings are sold by component

A DURA-FLEX Assembly consists of one element (STD or Spacer) and two hubs (BTS or QD). Optional high speed rings may also be ordered for spacer elements. Below is an ordering example for Dura-Flex Couplings.

	Part #	Description	Size 20 Example
Element (1)	WE2M – WE80M	Standard Metric Element, sizes 2 through 80	WE20M
	WES2M – WES80M	Spacer Metric Element, sizes 2 through 80	WES20M
Hubs (2)	WE[2-80] HMPB	BTS Hubs – MPB suitable to rebore	WE20HMPB
	WE[3-80] HMTL Bushing	TL Hubs (sizes 3 through 80, bushing not included)	WE20HMTL
*HS Rings (1)	WE[20-80]RM	High speed rings – sizes 20-80 (standard for sizes 2-10)	WE20RM

*Spacer element only

COUPLING RATINGS (STD & SPACER)

Coupling Size	KW @ RPM				Torque (Nm)	Stiffness NM/RAD	Maximum Rpm		Max. Misalignment	
	100	970	1450	3000			Standard	Spacer *	Parallel (MM)	Angular
WE2M	0.22	2.2	3.2	6.7	22	358	7500	7500	1.6	4°
WE3M	0.43	4.2	6.3	13	41	532	7500	7500	1.6	4°
WE4M	0.66	6.4	9.5	20	62	607	7500	7500	1.6	4°
WE5M	1.1	11	16	33	105	1110	7500	7500	1.6	4°
WE10M	1.7	17	25	51	164	1790	7500	7500	1.6	4°
WE20M	2.7	26	39	82	260	3120	6600	4800	2.4	3°
WE30M	4.3	42	63	130	412	4770	5800	4200	2.4	3°
WE40M	6.6	64	96	198	621	7370	5000	3600	2.4	3°
WE50M	9.1	88	131	272	864	13900	4200	3100	2.4	3°
WE60M	15	144	215	444	1412	18900	3800	2800	3.2	2°
WE70M	26	254	380	786	2500	23200	3600	2600	3.2	2°
WE80M	47	454	678	1403	4463	34500	2000	1800	3.2	2°

*Maximum spacer RPM = Maximum standard RPM if using optional high speed rings

Dura-Flex® Metric BTS Couplings

Dimensions

Assembly Dimensions for BTS Couplings.

(All dimensions in millimeters) Minimum Shaft Spacing = 6.35mm

Dimensions Common to BTS Standard and Spacer Assemblies

SIZE	A	B	C	Max Bore
WE2M & WES2M	94	47	24	29
WE3M & WES3M	108	59	38	35
WE4M & WES4M	115	66	43	42
WE5M & WES5M	137	80	44	48
WE10M & WES10M	165	93	48	54
WE20M & WES20M	187	114	52	60
WE30M & WES30M	214	138	59	73
WE40M & WES40M	247	168	64	86
WE50M & WES50M	288	207	70	92
WE60M & WES60M	318	222	83	102
WE70M & WES70M	356	235	92	114
WE80M & WES80M	406	287	124	152

Standard Element Assembly

Product No.	OAL MAX	OAL MIN	Maximum DBSE	Weight kg
WE2M	96	82	48	.68
WE3M	110	97	34	1.5
WE4M	119	97	33	2.0
WE5M	135	110	46	3.4
WE10M	141	105	46	5.1
WE20M	173	109	69	7.4
WE30M	193	118	76	12.6
WE40M	207	129	80	20.6
WE50M	234	147	94	26.8
WE60M	272	164	107	37.5
WE70M	279	183	123	49.4
WE80M	375	236	169	110

Product number is element only.

Spacer Element Assembly

Product No.	OAL MAX	OAL MIN	Maximum DBSE	Weight kg
WES2M	145	145	103	1.1
WES3M	204	185	128	2.2
WES4M	213	185	127	2.8
WES5M	216	185	127	4.3
WES10M	223	185	127	6.2
WES20M	284	237	180	8.7
WES30M	296	237	180	14.1
WES40M	302	237	175	22.2
WES50M	313	237	173	28.8
WES60M	414	315	248	41.3
WES70M	427	318	243	58.1
WES80M	501	318	248	117.0

Product number is element only.

Shaft Spacing from 6.35 mm up to the MAX DBSE can be accommodated by positioning hubs IN or OUT or by using various existing hole patterns. OAL — Over All Length does not include bolt heads.

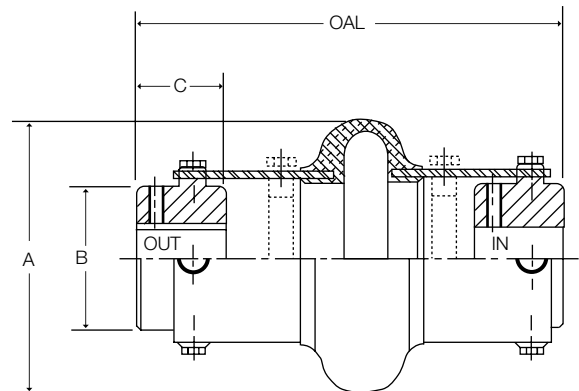
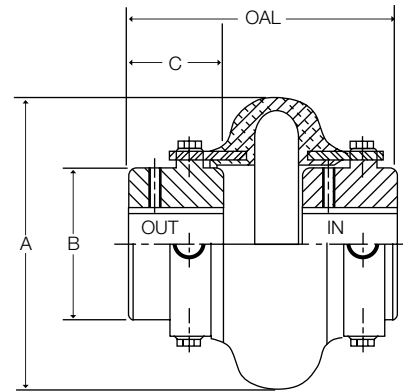

Sizes WES2M through WES10M are furnished with high speed rings. All larger sizes, rings can be ordered as an option.

All weights shown are with MPB style hubs.

Dura-Flex® Metric Taper-Lock® Bushed Couplings

Dimensions

Assembly Dimensions for TAPER-LOCK® Bushed Couplings.

(All dimensions in millimeters) Minimum Shaft Spacing = 6.35 mm

Dimensions Common to TAPER-LOCK® Bushed Standard and Spacer Assemblies

SIZE	A	B	H	Bushing	Max Bore
WE3M & WES3M	108	59	22	TL1008	26
WE4M & WES4M	115	66	22	TL1008	26
WE5M & WES5M	137	80	22	TL1210	32
WE10M & WES10M	165	93	25	TL1610	44
WE20M & WES20M	187	114	25	TL1610	44
WE30M & WES30M	214	138	32	TL2012	55
WE40M & WES40M	247	168	44	TL2517	68
WE50M & WES50M	288	207	44	TL2517	68
WE60M & WES60M	318	222	51	TL3020	82
WE70M & WES70M	356	235	89	TL3535	100
WE80M & WES80M	406	287	102	TL4040	113

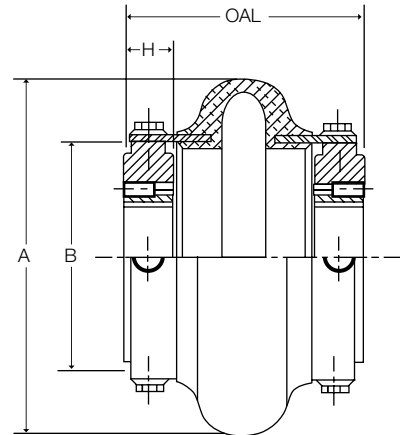

Standard Element Assembly

Product No.	OAL	Maximum DBSE	Weight kg
WE3M	87	43	0.8
WE4M	87	43	1.2
WE5M	100	56	1.8
WE10M	103	52	2.7
WE20M	114	64	4.1
WE30M	129	65	6.2
WE40M	149	60	9.9
WE50M	165	76	14.3
WE60M	186	84	21.1
WE70M	238	60	30.3
WE80M	298	95	37.2

Product number is element only.

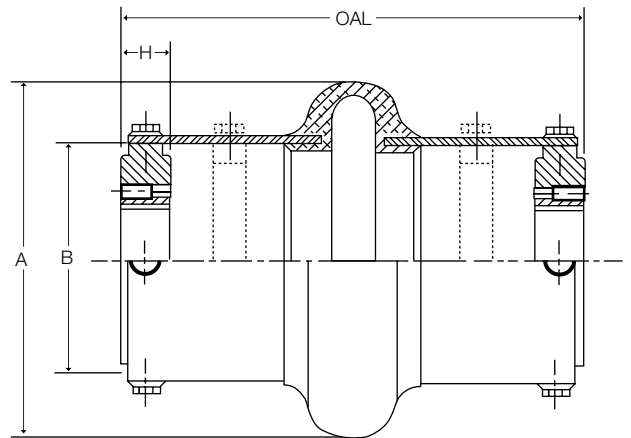

Spacer Element Assembly

Product No.	OAL MAX	OAL MIN	Maximum DBSE	Weight kg
WES3M	185	185	137	1.5
WES4M	185	185	137	1.9
WES5M	185	185	137	2.7
WES10M	185	185	133	3.6
WES20M	237	237	174	5.4
WES30M	237	237	168	8.2
WES40M	244	237	155	12.2
WES50M	244	237	155	17.0
WES60M	328	315	226	27.5
WES70M	364	318	186	36.9
WES80M	377	318	174	42.3

Product number is element only.

© TAPER-LOCK: J.H. Fenner & Co. Limited, England.

Shaft Spacing from 6.35 mm up to the MAX DBSE can be accommodated by positioning hubs IN or OUT or by using various existing hole patterns.
OAL — Over All Length does not include bolt heads.

Sizes WES3M through WES10M are furnished with high speed rings. All larger sizes, rings can be ordered as an option.

All weights shown are with MPB bushings.

We Have A Product For All Your Coupling Needs

Besides the full line of stock DURA-FLEX couplings —
Wood's has other stock coupling lines that may fill your application.



Sure-Flex Plus®

- Operates in shear
- No lubrication
- Four-way flexibility
- Easy installation

**Up to 115 HP
@ 100 rpm**

Gear Couplings

- High Torque Capacity
- Torsionally Stiff
- Good Inherent Balance
- Rated for Higher Speeds
- Many Types and Configurations

**Up to 2714 HP
@ 100 rpm**



Jaw Couplings

- Economical
- No maintenance
- Industry standard
- Large inventories

**Up to 30 HP
@ 100 rpm**

Form-Flex®

- All metal construction
- No lubrication
- Wide temperature range
- Zero backlash
- API offering

**Up to 3175 HP
@ 100 rpm**



L-Jaw Elastomeric Couplings

F3

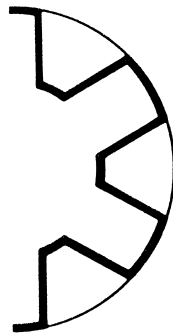

- 100% interchangeable with industry standard
- 3 Insert materials available
- 3 Hub materials available
- Large selection of sizes

Jaw Couplings

Selection

Determine the Prime Mover Classification

Prime Mover	Class
• Electric Motors (Standard duty), Hydraulic Motors, Turbines	A
• Gasoline or Steam Engines (4 or more cylinders)	B
• Diesel or Gas Engines, High Torque Electric Motors	C

Determine the Load Characteristics and the Service Factor

Typical Applications	Load	Characteristics	Prime Mover Class		
			A	B	C
Agitators (pure liquids), Blowers (centrifugal), Can and Bottle Filling Machines, Conveyors - uniformly loaded or fed (belt, chain, screw), Fans (centrifugal), Generators (uniform load), Pumps (centrifugal), Screens (air washing, water), Stokers (uniform load), Woodworking Machines (planers, routers, saws)	Uniform	Even loads – no shock – non reversing – infrequent starts (up to 10 per hour) – low starting torques – Up to 8 hours per day – Over 8 hours per day	1.0 1.5	1.5 2.0	2.0 2.5
Beaters, Blowers (lobe, vane), Compressors (centrifugal, rotary), Conveyors - non uniformly loaded or fed (belt, bucket, chain, screw), Dredge Pumps, Fans (forced draft, propeller), Kilns, Paper Mills (calendars, converting machines, conveyors, dryers, mixers, winders), Printing Presses, Pumps (gear, rotary), Shredders, Textile Machinery (dryers, dyers)	Moderate shock	Uneven loads – moderate shock – Infrequent reversing – moderate torques – Up to 8 hours per day – Over 8 hours per day	1.5 2.0	2.0 2.5	2.5 3.0
Cranes (bridge, hoist, trolley), Fans (cooling tower), Generators (welding), Hammer Mills, Mills (ball, pebble, rolling, tube, tumbling), Pumps (oil well), Wire Drawing Machines	Heavy shock	Uneven loads – heavy shock – frequent starts and stops – high starting torques – high inertia peak loads – Up to 8 hours per day – Over 8 hours per day	2.0 2.5	2.5 3.0	3.0 3.5

Note: The above applications depict generally accepted conditions encountered in industry. Extreme temperatures, abrasive dusts, corrosive liquids/dusts, excessively high starting torques, etc., must be considered as extra heavy shock loads. These conditions will increase service factors. Consult factory for these selections.

Calculate Design Horsepower or Design Torque

- If Prime Mover is a 1200, 1800, or 3600 RPM motor
Design HP = Prime Mover HP x Service Factor
Go to page F3—3 and reference the corresponding motor RPM column
- If Prime Mover is not one of the three speeds listed above
Design Hp @ 100 RPM = (Prime Mover HP x Service Factor x 100) / Coupling RPM
Go to page F3—3 and reference HP @ 100 RPM column
- If Using Prime Mover Torque
Design Torque = Prime Mover Torque x Service Factor
Go to page F3—3 and reference Torque column

Coupling Ratings

Hub	Max Bore	Max RPM	Buna-N Spider			Urethane Spider			Hytrek Spider		
			Spider	Torque (in. lbs)	HP @ 100 RPM	Spider	Torque (in. lbs)	HP @ 100 RPM	Spider	Torque (in. lbs)	HP @ 100 RPM
L035	3/8	31000	L035N	3.5	0.006						
L050, AL050	5/8	18000	L050N	26	0.042	L050U	39	0.06	L050H	50	0.08
L070, AL070	3/4	14000	L070N	43	0.069	L070U	65	0.10	L070H	114	0.18
L075, AL075, SS075	7/8	11000	L075N	90	0.14	L075U	135	0.21	L075H	227	0.36
L090, AL090	1	9000	L090N	144	0.23	L090U	216	0.35	L090H	401	0.64
L095, AL095, SS095 ①	1-1/8	9000	L090N	194	0.31	L090U	291	0.47	L090H	561	0.89
L099	1-3/16	7000	L099N	318	0.51	L099U	477	0.77	L099H	792	1.3
L100, AL100, SS100 ②	1-7/16 ④	7000	L099N	417	0.66	L099U	626	1.0	L099H	1134	1.8
L110, AL110, SS110	1-5/8	5000	L110N	792	1.3	L110U	1188	2.0	L110H	2268	3.6
L150, AL150, SS150 ③	1-7/8	5000	L150N	1240	2.0	L150U	1860	3.0	L150H	3708	5.9
L190	2-1/8	5000	L190N	1726	2.7	L190U	2589	4.1	L190H	4680	7.4
L225	2-5/8	4600	L225N	2340	3.7	L225U	3510	5.6	L225H	6228	9.9
L276	2-7/8	4200	L276N	4716	7.5						

① Uses L090 spiders ② Uses L099 spiders ③ AL150 - Use Buna-N spiders only ④ 1-3/8 for AL and SS hubs

Coupling HP @ RPM

Hub	Spider	Buna-N Spider			Spider	Urethane Spider			Spider	Hytrek Spider		
		HP @ RPM				HP @ RPM				HP @ RPM		
		1200	1800	3600		1200	1800	3600		1200	1800	3600
L035	L035N	0.07	0.10	0.20								
L050, AL050	L050N	0.50	0.75	1.5	L050U	0.75	1.1	2.3	L050H	0.95	1.4	2.9
L070, AL070	L070N	0.8	1.2	2.5	L070U	1.2	1.8	3.8	L070H	2.2	3.3	6.5
L075, AL075, SS075	L075N	1.7	2.6	5.1	L075U	2.6	3.9	7.7	L075H	4.3	6.5	13
L090, AL090	L090N	2.7	4.1	8.2	L090U	4.0	6.2	12	L090H	7.6	11	23
L095, AL095, SS095 ①	L090N	3.7	5.5	11	L090U	5.6	8.3	17	L090H	11	16	32
L099	L099N	6.0	9.1	18	L099U	9.0	14	27	L099H	15	23	45
L100, AL100, SS100 ②	L099N	7.9	12	24	L099U	12	18	36	L099H	22	32	65
L110, AL110, SS110	L110N	15	23	45	L110U	23	35	68	L110H	43	65	130
L150, AL150, SS150 ③	L150N	24	35	71	L150U	36	53	107	L150H	71	106	212
L190	L190N	33	49	99	L190U	50	74	149	L190H	89	134	267
L225	L225N	45	67	134	L225U	68	101	201	L225H	119	178	356
L276	L276N	90	135	269								

Spider Characteristics

Characteristics	Buna-N	Urethane	Hytrek
Oil Resistance	Good	Good	Excellent
Chemical Resistance	Poor	Good	Excellent
Flexibility	Excellent	Good	Fair
Temperature Range	F -40 to +212 C -40 to +100	-30 to +160 -35 to +71	-60 to +250 -51 to +121
Torsional Stiffness	Full Soft	Medium Soft	Hard
Avg Shore Hardness	80A	90A	55D
Max. Misalignment			
• Angular	1°	1°	1/2°
• Parallel	.015"	.015"	.015"
Color	Black	Blue	White

Order By Component – Example

	Part Number	Description
Driver Hub	L09958	L099 x 5/8
Driven Hub	L09912NK	L099 x 1/2 No Keyseat
Spider	L099N	L099 Buna-N

Stock Bores

Dimensions

Stock L-Jaw Inch Hubs

Bore Size	Bore Designation	L035	L050	L070	L075	L090	L095	L099	L100	L110	L150	L190	L225	L276
1/8	18	0												
3/16	3/16	0												
1/4	14	X	X	X	X	X								
5/16	5/16	0	0	X	0	X								
3/8	38	X	X	X	X	X								
7/16	7/16		X	X	X	X	X	X	X					
1/2	12		X	X	X	X	X	X	X					
9/16	9/16		1	1	X	1	1	1	X					
5/8	58		X	X	1	1	1	1	1	X	X			
11/16	11/16			1	1	1	1	1	1					
3/4	34			1	1	X	1	1	1	1	1	X	X	
7/8	78				1	1	1	1	1	1	1	1	1	0
15/16	15/16					1	1	1	1	1	1	1	1	
1	1					1	1	1	1	1	1	1	1	
1-1/16	1116						1		1	1	1		1	
1-1/8	118						1	1	1	1	1	1	1	1
1-3/16	1316							1	1	1	1	1	1	
1-1/4	114								1	1	1	1	1	1
1-5/16	1516								1	1				
1-3/8	138								1	1	1	1	1	1
1-7/16	1716								1	1	1	1	1	
1-1/2	112									1	1	1	1	
1-9/16	1916									1	1		1	
1-5/8	158									1	1	1	1	1
1-11/16	11116										1	1	1	
1-3/4	134										1	1	1	1
1-13/16	11316										1			
1-7/8	178										1	1	1	
1-15/16	11516											1	1	
2	2											1	1	1
2-1/8	218											1	1	1
2-3/16	2316												1	
2-1/4	214												1	1
2-3/8	238												1	
2-1/2	212												1	1
2-5/8	258												1	
2-7/8	278													1

0 No Keyseat 1 Standard Keyseat X No Keyseat or Standard Keyseat

Part Number Examples

L095118 L095 x 1-1/8" Hub
 L07512NK L075 x 1/2" No Keyseat Hub
 L09515/16 L095 x 15/16" Hub

Bore Tolerances

Bore Size	Tolerance
Up to and including 2"	+ .0005"
	+ .0015"
Over 2"	+ .0005"
	+ .0020"

Standard Keyseat Dimensions

Shaft Diameter	Width	Depth
1/2 to 9/16	1/8	1/16
5/8 to 7/8	3/16	3/32
15/16 to 1-1/4	1/4	1/8
1-5/16 to 1-3/8	5/16	5/32
1-7/16 to 1-3/4	3/8	3/16
1-13/16 to 2-1/4	1/2	1/4
2-5/16 to 2-3/4	5/8	5/16
2-13/16 to 3-1/4	3/4	3/8
3-5/16 to 3-3/4	7/8	7/16
3-13/16 to 4-1/2	1	1/2
4-9/16 to 5-1/2	1-1/4	5/8
5-9/16 to 6-1/2	1-1/2	3/4

Dimensions

Stock L-Jaw Metric Bore Hubs

Bore (mm)	Bore Designation	L035	L050	L070	L075	L090	L095	L099	L100	L110	L150	L190	L225
5	5MM	0											
6	6MM	0											
7	7MM		0										
8	8MM	0	0	0									
9	9MM		1										
10	10MM		X	1									
11	11MM		1		1								
12	12MM		1	1	1	1	1						
14	14MM		X	1	1	1	1	1	1				
15	15MM		1	1	1	1	1	1	1				
16	16MM		1	1	1	1	1	1	1				
17	17MM				1		1						
18	18MM				1	1	1	1	1	1			
19	19MM			1	1	1	1	1	1	1			
20	20MM				1	1	1	1	1	1	1		
22	22MM				1	1	1	1	1	1			
24	24MM					1	1	1	1	1	1		
25	25MM					1	1	1	1	1	1	1	
28	28MM						1	1	1	1	1	1	
30	30MM							1	1	1	1	1	
32	32MM								1	1	1	1	1
35	35MM								1	1	1	1	
38	38MM									1	1	1	1
40	40MM									1	1	1	1
42	42MM									1	1	1	1
45	45MM										1	1	1
48	48MM										1	1	1
50	50MM											1	1
55	55MM												1
60	60MM												1
65	65MM												1

0 No Keyseat 1 Standard Keyseat X No Keyseat or Standard Keyseat

Stock Aluminum L-Jaw Hubs

Bore Size	Bore Designation	AL050	AL070	AL075	AL090	AL095	AL100	AL110	AL150
1/4	14	0							
5/16	5/16	0							
3/8	38	0							
7/16	7/16	0	0						
1/2	12	0	0	X	0	0			
5/8	58	0	1	1	1	1			
3/4	34		1	1	1	1	1		
7/8	78			1	1	1	1		
1	1				1	1	1	1	
1-1/8	118					1	1	1	1
1-1/4	114						1	1	1
1-3/8	138						1	1	1
1-1/2	112							1	1
1-5/8	158							1	1
1-3/4	134								1
1-7/8	178								1

0 No Keyseat 1 Standard Keyseat X No Keyseat or Standard Keyseat

Stock Stainless Steel L-Jaw Hubs

Bore Size	Bore Designation	SS075	SS095	SS100	SS110	SS150
1/4	14	0				
1/2	12	1	1			
5/8	58	1	1			
3/4	34	1	1	1		
7/8	78	1	1	1		
1	1		1	1	1	1
1-1/8	118		1	1	1	1
1-3/8	138			1	1	1
1-1/2	112				1	1
1-5/8	158				1	1
1-3/4	134					1
1-7/8	178					1

0 No Keyseat
1 Standard Keyseat

Metric Bore Tolerances

Bore Size	Tolerance (mm)
5 to 6mm	+0.010 +0.022
7 to 10mm	+0.013 +0.028
11 to 18mm	0.016 +0.034
19 to 30mm	+0.020 +0.041
32 to 50mm	+0.025 +0.050
55 to 65mm	+0.030 +0.060

Metric Keyseat Dimensions

Shaft Diameter	Width (mm)	Depth (mm)
6mm	2	1.0
9 to 10mm	3	1.4
11 to 12mm	4	1.8
13 to 17mm	5	2.3
18 to 22mm	6	2.8
23 to 30mm	8	3.3
31 to 38mm	10	3.3
39 to 44mm	12	3.3
45 to 50mm	14	3.8
51 to 58mm	16	4.3
59 to 65mm	18	4.4

Part Number Examples

L09924MM L099 x 24mm Hub
AL09512NK AL095 x 1/2" No Keyseat Hub
SS150178 SS150 x 1-7/8" Hub

L-Jaw Couplings

Dimensions

AL, SS, L035 - L150

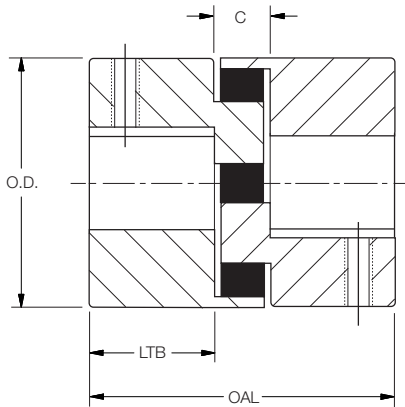

L190 - L276

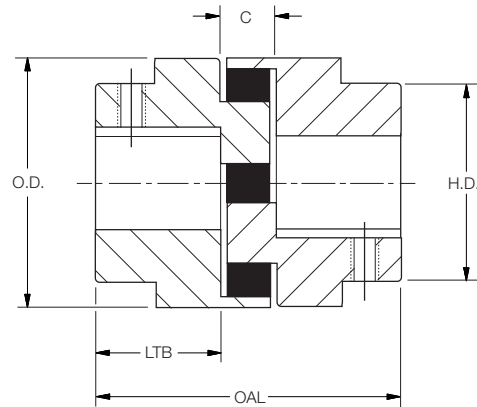

L-Jaw Dimensions

Coupling Size	Hub Material	Dimensions					Weight (Lbs)*		
		OD	HD	LTB	OAL	C	S.I.	AL	S.S.
L035	S.I.	0.63		0.27	0.81	0.28	0.1		
L050, AL050	S.I., AL	1.08		0.63	1.72	0.47	0.3	0.1	
L070, AL070	S.I., AL	1.36		0.75	2.00	0.50	0.6	0.2	
L075, AL075, SS075	S.I., AL, S.S.	1.75		0.81	2.13	0.50	1.0	0.4	1.2
L090, AL090	S.I., AL	2.11		0.81	2.13	0.50	1.5	0.6	
L095, AL095, SS095	S.I., AL, S.S.	2.11		1.00	2.50	0.50	1.8	0.7	2.2
L099	S.I.	2.53		1.06	2.88	0.75	2.5		
L100, AL100, SS100	S.I., AL, S.S.	2.53		1.38	3.50	0.75	3.5	1.4	4.1
L110, AL110, SS110	S.I., AL, S.S.	3.33		1.69	4.23	0.85	6.6	3.0	8.6
L150, AL150, SS150	S.I., AL, S.S.	3.75		1.75	4.50	1.00	9.1	4.2	12
L190	C.I.	4.50	4.00	1.94	4.88	1.00	17		
L225	C.I.	5.00	4.25	2.19	5.38	1.00	23		
L276	C.I.	6.19	5.00	3.13	7.88	1.63	47		

S.I. = Powdered metal • C.I. = Cast Iron • AL = Aluminum • S.S. = Stainless Steel

*Weight of coupling with minimum bore hubs

G-Flex Grid Couplings

The Original Bibby
Grid Coupling

F4



- Long Life
- Low Maintenance
- Design Flexibility

G-Flex Grid Couplings

Features

Principal of Operation

Positive protection against the damaging effects of shock loads, impact loads and vibration.

The grid is torsionally flexible. The circumferential flexibility is progressive due to the curved profile of the grooves – ‘state-of-the-art’ in resilient coupling design.

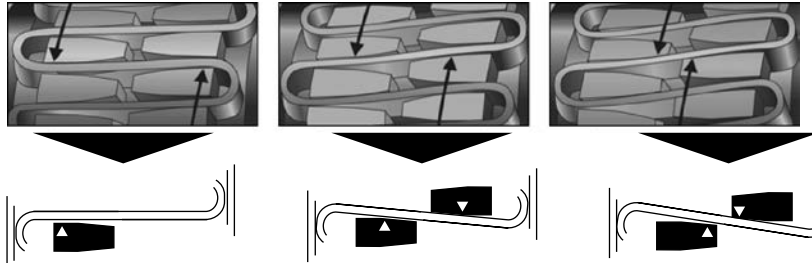

Accommodating Shaft Misalignment and End-Float

The grid will accommodate combinations of misalignments present at set-up or occurring during machine displacement, settlement, etc.

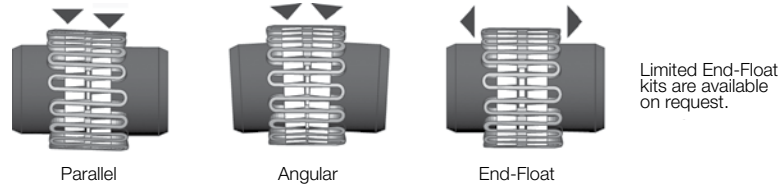

Effectiveness of Torsional Damping

As the grid coupling transmits torque, the flexing of the tapered grid spring damps vibrations and cushions shock loads.

This unique characteristic is due to the torsional flexibility of the coupling being proportionate to the unsupported length of each flexible grid rung. The resultant reduction in peak loading protects and extends the life of the transmission equipment.

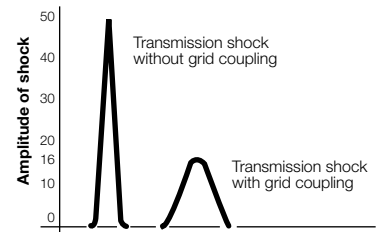

Versatile Design

Both 1000T10 and 1000T20 couplings feature identical hubs and grid springs, the different cover styles provide great versatility – one is horizontally split “T10”, the other is vertically split “T20”.

All coupling components are designed to be interchangeable with other taper grid couplings. The stock coupling can be used vertically or horizontally without modification.

Easy Installation and Maintenance

The grid springs are easily installed by hand or with a soft mallet. The cover fasteners can be tightened with standard wrenches. Every TB Wood’s coupling is delivered with detailed installation instructions. Periodic Lubrication of the coupling is required and each cover half is supplied with standard plugs which can be easily removed for re-lubrication.

Recommended Fits between Shafts and Hubs

Coupling bore tolerances for sizes up to and including 1090T can be specified to suit a clearance fit with the shaft. In these instances the hub is provided with set screws. Relative positions are given in the following table.

“S” Position from Hub Faces

1020 = 1.2”	1060 = 2.0”
1030 = 1.3”	1070 = 2.1”
1040 = 1.5”	1080 = 2.5”
1050 = 1.7”	1090 = 2.8”

For sizes above 1090T or where interference fits are preferred for smaller coupling sizes, bore tolerances will be consistent with AGMA standards.

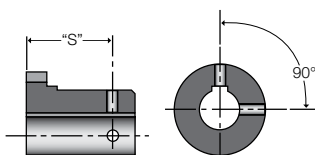

Taper Grid Resilient Couplings

Series 1000T10 And Series 1000T20

Dr. James Bibby originally invented the Resilient Coupling in 1917 and the 1000 Series is the latest level of this well accepted product. This Bibby Turboflex product has become universally accepted where reliable protection against shaft misalignment and vibration is desirable.

Since those early days refinements in design and material specifications have kept pace with advancing technology, achieving significant improvements in power/weight ratios.

TB Woods is proud to offer this proven product.



1000T10

- Horizontally Split Cover
- General Purpose
- Easy access to grid minimizes downtime
- Ideal for limited space applications
- Stop lug in cover prevents spinning during reversing service



1000T20

- Vertically Split Cover
- General purpose
- Ideal for higher running speeds

High Performance

The TB Wood's Taper Grid Coupling continues that tradition. The tapered grid is made from high tensile alloy steel which is carefully formed to the grid shape before hardening and tempering under controlled conditions. The grid surface is then shot-peened. This process leaves the grid spring with a residually stressed surface layer which is in compression and which impedes the propagation of cracks. Since nearly all fatigue and stress corrosion failures originate at the surface of a part, the layer of compressive stress induced by shot-peening produces a dramatic increase in the working life and fatigue strength of the grid. This technological improvement in manufacturing process coupled with precise monitoring of raw material specification and control of trapezoidal shape, permits TB Wood's to offer state of the art grid springs of high performance and reliability.

Scientific Design

The hub is precision manufactured from high quality materials, with the hub tooth profile scientifically designed to permit progressive loading under torsional shock conditions. The combination of tapered grid and precision manufactured hub provides easy assembly. The excellent shock absorption characteristics, and the ability to accommodate misalignment protects the connected equipment.

Long Life

While the coupling is designed for long life under tough conditions, maintenance and taper grid replacement can be performed quickly and easily without the need to move and realign connected equipment. Two cover design options are available in the TB Wood's range of couplings. Both designs have been carefully engineered to provide a shaft coupling which is highly reliable and easy to install.

Horizontally Split Cover Couplings

Series 1000T10

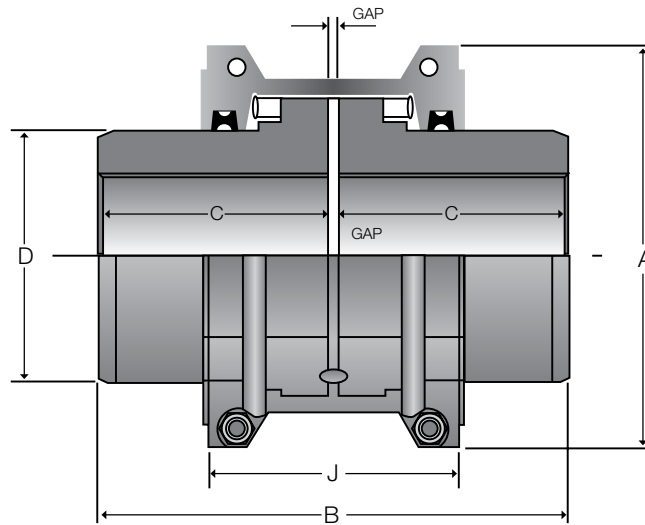

SIZE	COUPLING RATING (IN-LBS)	MAX SPEED	MIN BORE (IN)	MAX BORE (IN)**	CPLG WT (LBS)*	WR ² / (LB/FT ²)*	DIMENSIONS IN INCHES					
							A	B	C	D	J	GAP
1020	460	4500	0.50	1.13	4.0	4.8	4.02	3.86	1.87	1.56	2.64	0.13
1030	1,319	4500	0.50	1.38	5.3	7.5	4.37	3.86	1.87	1.94	2.68	0.13
1040	2,204	4500	0.50	1.63	7.1	11	4.65	4.13	2.00	2.25	2.76	0.13
1050	3,850	4500	0.50	1.88	12	24	5.43	4.88	2.37	2.63	3.11	0.13
1060	6,054	4350	0.75	2.13	16	41	5.94	5.12	2.50	3.00	3.62	0.13
1070	8,798	4125	0.75	2.50	22	62	6.38	6.14	3.00	3.44	3.74	0.13
1080	18,144	3600	1.06	3.00	39	154	7.64	7.13	3.50	4.13	4.57	0.13
1090	33,013	3600	1.06	3.50	54	269	8.39	7.87	3.87	4.87	4.80	0.13
1100	55,582	2440	1.63	4.00	91	615	9.88	9.69	4.75	5.59	6.14	0.19
1110	82,489	2250	1.63	4.50	118	923	10.63	10.20	5.00	6.31	6.42	0.19
1120	121,255	2025	2.38	5.00	174	1743	12.13	12.01	5.87	7.06	7.56	0.25
1130	176,129	1800	2.63	6.00	260	3383	13.66	12.99	6.37	8.56	7.68	0.25
1140	253,130	1650	2.63	7.25	388	6322	15.12	14.76	7.25	10.00	7.91	0.25

* Coupling weight and WR² with no bore

** Max bore is for hub with keyway for rectangular key

Vertically Split Cover Couplings

Series 1000T20

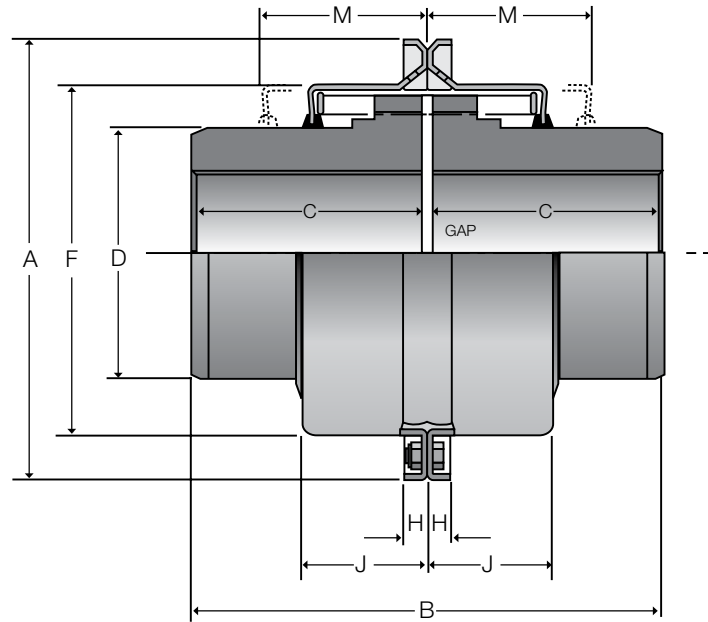

SIZE	COUPLING RATING (IN-LBS)	MAX RPM	MIN BORE (IN)	MAX BORE (IN)**	CPLG WT (LBS)*	WR2/ (LB/ FT2)*	DIMENSIONS IN INCHES								
							A	B	C	D	F	H	J	M	GAP
1020	460	6000	0.50	1.13	3.5	3.8	4.37	3.86	1.87	1.56	2.48	0.37	0.96	1.89	0.13
1030	1,319	6000	0.50	1.38	4.9	6.2	4.76	3.86	1.87	1.94	2.83	0.37	0.99	1.89	0.13
1040	2,204	6000	0.50	1.63	6.6	9.2	5.08	4.13	2.00	2.25	3.15	0.37	1.02	2.01	0.13
1050	3,850	6000	0.50	1.88	11	22	5.83	4.88	2.37	2.63	3.82	0.51	1.24	2.40	0.13
1060	6,054	6000	0.75	2.13	15	34	6.38	5.12	2.50	3.00	4.33	0.51	1.27	2.52	0.13
1070	8,798	5500	0.75	2.50	21	55	6.81	6.14	3.00	3.44	4.76	0.51	1.33	2.64	0.13
1080	18,144	4750	1.06	3.00	37	133	7.87	7.13	3.50	4.13	5.87	0.51	1.74	3.50	0.13
1090	33,013	4000	1.06	3.50	52	246	9.13	7.87	3.87	4.87	6.61	0.51	1.86	3.78	0.13
1100	55,582	3250	1.63	4.00	87	588	10.51	9.69	4.75	5.59	7.80	0.63	2.37	4.76	0.19
1110	82,489	3000	1.63	4.50	114	892	11.26	10.20	5.00	6.31	8.50	0.63	2.49	4.88	0.19
1120	121,255	2700	2.38	5.00	167	1709	12.56	12.01	5.87	7.06	9.69	0.63	2.91	5.63	0.25
1130	176,129	2400	2.63	6.00	254	3691	14.88	12.99	6.37	8.56	11.18	0.87	2.97	5.79	0.25
1140	253,130	2200	2.63	7.25	381	6475	16.38	14.76	7.25	10.00	12.68	0.87	3.09	6.14	0.25

* Coupling weight and WR² with no bore

** Max bore is for hub with keyway for rectangular key

Coupling Selection

Procedure

Use the Application Service Factor table, Torque Rating and Maximum Coupling Bore Sizes tables to assist you in the selection procedure for products listed in this catalog. Contact TB Wood's technical staff to discuss any special requirements.

1. Select Service Factor (SF).
From Table 1 (see page F4-8) and
Table 1A (see page F4-9)

2. Calculate required minimum
basic rating:

a) Normal Service (Nominal Torque)

$$\text{Basic Rating (in.lb.)} = \frac{\text{Transmitted Power (HP)} \times 63025 \times \text{SF}}{\text{RPM}}$$

b) Repetitive High Peak Torque Applications – See *Note

c) Non Reversing Duty

$$\text{Selection Torque (in.lb.)} = \text{Nominal Torque (from a. above)}$$

$$\text{Selection Torque (in.lb.)} = 2 \times \text{Nominal Torque (from a. above)}$$

3. Select coupling having a basic rating equal to or exceeding the calculated value.
4. Check that speed does not exceed the coupling maximum speed.
5. Use Maximum Coupling Bore Sizes Table to determine Maximum Coupling Bore suitable for respective driving and driven shafts.

***Note:**

- The system peak torque is the maximum load created by the driving or driven equipment.
- Occasional peak torques of twice the catalog rating can be accommodated providing they occur less than 1000 times during the life of the coupling.

Recommended fit between shafts and hubs

Stock bore hubs are supplied with a clearance fit on sizes VP to and including 1090. Larger sizes are supplied with an interference fit.

How To Select A Grid Coupling

The standard selection method can be used for most motor or engine driven applications. The following information is required to make a selection.

- 1 Power to be handled (HP) - P
- 2 (Alternative to Power is Torque (in.lb.) - T
- 3 Speed of operation (rpm) - N
- 4 Distance between the Shaft Ends - DBSE
- 5 Shaft Diameters for Driver & Driven Machines - D1 & D2

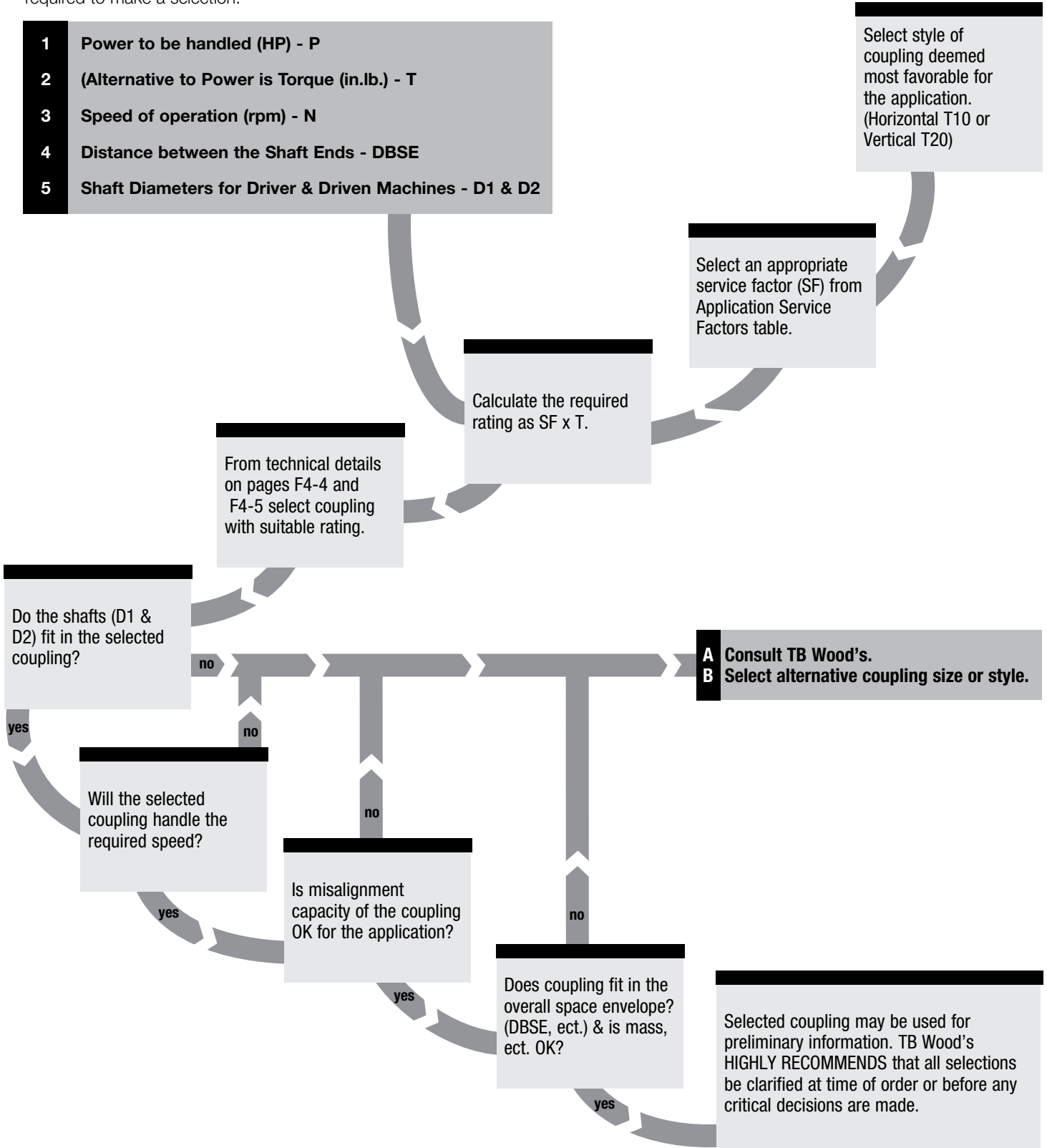

Application Service Factors

Table 1

Application	Service Factor	Application	Service Factor	Application	Service Factor
Agitators	1.0	Laundry Machines	2.0	Rubber Industry	
Blowers		Machine Tools		Extruder	1.75
Centrifugal	1.0	Main drives	1.5	Calender	2.0
Lobe/Vane	1.25	Notching press/Planer/Punch	1.75	Bunbury mixer/Cracker/Mixing	
Clay Working Machines		Auxiliary and traverse drives	2.0	mill/Plasticator/Refiner	2.5
Brick press, Pug mill, Briquette machine ..	1.75	Metalworking		Steel Industry	
Compressors		Presses	2.0	Soaking pit/Cover drive:	
Centrifugal	1.0	Hammers	2.0	Lift	1.0
Lobe/Rotary	1.25	Straighteners	2.0	Travel	2.0
Reciprocating		Bending	1.5	Coilers (up or down) cold mills only	1.5
1 to 3 cylinders	3.0	Shears	1.5	Coilers (up or down) hot mills only	2.0
4 or more cylinders	1.75	Punching	2.0	Coke Plants	
Conveyors		Mills (Rotary type)		Pusher rain drive	2.5
Uniformly fed horizontal:		Ball or pebble	2.0	Door opener	2.0
Screw, Apron, Assembly, Belt, Chain,		Rod or tube	2.0	Pusher and Lorry car traction drive	3.0
Flight, Oven	1.0	Dryer and cooler	1.75	Cold mills – Strip and temper mills	2.0
Heavy Duty:		Mixers		Hot mills – Strip and sheet mills	3.0
Dredge, Inclined belt and screw	1.5	Drum	1.5	Reversing, blooming or slabbing mills	
Reciprocating	3.0	Concrete (continuous or intermittent)	1.75	Refer to TB Wood's	
Cranes and Hoists		Grizzly	2.0	Edging mills	
Main hoist – medium duty/mine haulage	2.5	Oil Industry		Refer to TB Wood's	
Main hoist – heavy duty	3.0	Chiller	1.25	Cooling beds	1.5
Long or cross travel/Slew or luff skip		Oil well pumping		Wire drawing/Slitters, steel mills only	1.75
hoist/slope	1.75	(<than 150% peak torque)	2.0	Drawbench/Furnace pusher/hot	
Crushers	2.5	Paper Mills		and cold saws/Ingot curs/Reelers/	
Dredgers	2.0	Bleacher	1.0	Straighteners	2.0
Elevators		Felt stretcher	1.25	Seamless tube mills piercer/	
Centrifugal and gravity discharge	1.25	Stock chest/stock pump – rotary/winder	1.5	Rod mills/mill tables/Manipulators/ Feed	
Fans		Bleacher and pulper/Calender/Couch/		rolls-blooming mills	3.0
Centrifugal	1.0	Dryer/Fourdrinier/ Press/Pulp grinder/		Sugar Industry	
Forced draft	1.5	Suction roll	1.75	Cane carrier and leveller	1.75
Induced draft with damper	1.5	Jordan/Stock pump-reciprocating	2.0	Cane knife and crusher	2.0
Mine/Cooling tower	2.0	Barking drum/Chipper	2.5	Mill stands Turbine driven-Helical	
Induced draught without control	2.0	Plastic		or Herringbone gears	1.5
Food		Calenders/Crushers/Extruders/Mixers	1.5	Electric drive or steam driven with	
Beet slicer	1.75	Pulverizers		all Helical or Herringbone or spur	
Cereal cooker	1.25	Roller/Hammer mill, light duty	1.5	gears with any prime mover	1.75
Dough mixer	1.75	Hog/Hummer mill, heavy duty	1.75	Textiles	
Meat grinder	1.75	Pumps		Batcher	1.25
Bottling, can filling	1.00	Centrifugal	1.0	Dyeing machinery	1.25
Generators		Descaling with accumulators/ Rotary gear,		Calender/Card machine/Dry can/Loom	1.5
Even load	1.0	Lobe and Vane	1.25	Tobacco and Cigarette Machinery	1.5
Hoist and Railway service	1.5	Reciprocating		Water Waste Treatment	
Welder load	2.0	1 cylinder, single or double acting	3.0	Aerators	1.5
Kiln	2.0	2 cylinder, single acting	2.0	Screw pumps	1.5
		2 cylinders, double acting	1.75	Screens	1.5
		3 cylinders or more	1.5	Wind Turbines	1.25
				Wood Working Machinery	
				Trimmers, haulage, barkers, planes, saws	2.0

The above service factors are for general guidance only and should be considered as a minimum. They are complimentary to customers specialist knowledge for their own equipment.

Reciprocating Engines

Table 1A

Number of Cylinders	Service Factor
6 and over	0.5 + S.F. Table 1
4 or less	1.0 + S.F. Table 1
Less than 4	Refer to TB Wood's

For drives where the operation is near or actually passes through a major torsional natural frequency, a mass elastic analysis of the system is advised. When the Service Factor in Table 1 is greater than 2.0, consult your supplier or TB Wood's.

Rating – To determine the torque rating, calculate using the procedures given on page F4-6. Information may also be found on the nameplate of the motor, etc.

Service Factor – When selecting a coupling it is important to consider the characteristics of the drive and driven equipment. A figure known as the Service Factor has been calculated based on an average of a wide range of applications. This can be used as a guide in the selection process and is displayed in Table 1 on page F4-8.

Size – In making the decision from the following product groups which is most suited to the application, select a size equal to or higher than the rating calculated. Particular attention should be made to bore sizes, and guidance for this is in the Table related to Max Bore Sizes.

Speed – Ensure that the speed is compatible.

Should full information not be supplied to TB Wood's at the time of ordering, it will be the responsibility of the customer to ensure that the coupling has been correctly selected.

As our policy is one of continual improvement, this specification is not to be regarded as binding in any way, and is subject to alteration without notice. Certified drawings are available on request.

Stock Bores

Stock Grid Inch Hubs

BORE (IN.)	PRODUCT NO.	1020T	1030T	1040T	1050T	1060T	1070T	1080T	1090T	1100T	1110T	1120T	1130T	1140T
Solid-No bore	RB	X	X	X	X	X	X	X	X	X	X	X	X	X
1/2	12	X												
9/16	9/16	X												
5/8	58	X	X											
3/4	34	X	X	X	X									
7/8	78	X	X	X	X	X								
15/16	15/16	X	X	X	X									
1	1	X	X	X	X	X	X							
1-1/16	1116	X	X	X	X	X								
1-1/8	118	X	X	X	X	X	X							
1-3/16	1316		X	X										
1-1/4	114		X	X	X	X	X	X						
1-3/8	138		X	X	X	X	X	X	X					
1-7/16	1716			X	X	X	X	X	X					
1-1/2	112			X	X	X	X	X	X					
1-9/16	1916			X	X	X	X							
1-5/8	158			X	X	X	X	X	X					
1-11/16	11116				X		X	X						
1-3/4	134				X	X	X	X	X					
1-13/16	11316				X	X	X							
1-7/8	178				X	X	X	X	X					
1-15/16	11516					X	X	X	X					
2	2					X	X	X	X	X				
2-1/8	218					X	X	X	X	X				
2-3/16	2316						X	X						
2-1/4	214						X	X	X	X				
2-3/8	238						X	X	X	X				
2-7/16	2716						X	X	X	X				
2-1/2	212						X	X	X	X	X			
2-5/8	258							X	X	X				
2-11/16	21116							X						
2-3/4	234							X	X	X	X			
2-7/8	278							X	X	X	X			
2-15/16	21516							X	X	X				
3	3							X	X	X	X	X		
3-1/8	318								X	X				
3-1/4	314								X	X	X	X		
3-3/8	338								X	X	X			
3-7/16	3716								X	X	X			
3-1/2	312								X	X	X	X		
3-5/8	358								X	X	X			
3-3/4	334										X			
3-7/8	378									X	X	X		
3-15/16	31516									X	X	X		
4	4									X	X	X		
4-1/8	418										X			
4-3/16	4316										X			
4-7/16	4716										X			
4-1/2	412										X	X	X	
4-15/16	41516											X	X	
5	5											X		
5-7/16	5716												X	
Max Bore		1-1/8	1-3/8	1-5/8	1-7/8	2-1/8	2-1/2	3	3-5/8	4	4-1/2	5	6	7-1/4

Max bore is for hub w/ keyway for rectangular key

Example: Size 1020 coupling hub with 1-1/8" bore = 1020T118
 Size 1040 coupling hub with NO bore - for rebore = 1040TRB

Form-Flex® & Torsiflex-i Flexible Disc Couplings

F5



Table of Contents

Introduction

Product Features and Options	Page F5-3
Disc Coupling Advantages	Page F5-3
Typical Applications	Page F5-3
Coupling Application Types	Page F5-4
Coupling Selection Process	Page F5-5
Coupling Selection Guide	Page F5-6
Standard Bore Tolerances	Page F5-7
Industry Standard Reference	Page F5-8
Dynamic Balance Recommendations	Page F5-8
Disc Coupling Misalignment Discussion	Page F5-8
Product Differentiation	Page F5-9

Spacer Couplings

AP Series - Form-Flex®	Page F5-11
GP Series - Form-Flex®	Page F5-12, F5-13
TFI Series- Torsiflex-i - API610	Page F5-14, F5-15
TFI Series - Torsiflex-i - API610 with Torsi-Lock.....	Page F5-16, F5-17

Floating Shaft Couplings

A5 Series - Form-Flex®	Page F5-19
G5 Series - Form-Flex®	Page F5-20, F5-21
A5C Series (Composite) - Form-Flex®	Page F5-22, F5-23

Closed Coupled Couplings

AX Series - Form-Flex®	Page F5-25
AA Series - Form-Flex®	Page F5-26
AY Series - Form-Flex®	Page F5-27

Single Flex Couplings

AR Series - Form-Flex®	Page F5-29
GR Series - Form-Flex®	Page F5-30, F5-31

Heavy Duty Spacer Couplings

GCH Series - Form-Flex®	Page F5-33
GCF Series - Form-Flex®	Page F5-34
HSH Series - Form-Flex®	Page F5-35
FSH Series - Form-Flex®	Page F5-36
Coupling Repair Parts and Kits	Page F5-38, F5-39
Hub Options	Page F5-40, F5-41
Design Options.....	Page F5-42, F5-43
Bolt Thread Size	Page F5-44
Bolt/Nut Tightening Torque	Page F5-44
Application Data Sheet	Page F5-45, F5-46

Product Features and Options

Features	Form-Flex®						Torsiflex-i
	A-Series		G-Series				TFI
	AR, AP AX, AY, AA	A5, A6, A7	GP	G5	GR	GCH, GCF, HSH, FSH	
Standard Bore Fit:	Clearance		Interference				
Set Screws:	Standard		Optional				
Puller Holes:	Optional						Standard
Standard Flex Disc:	300 Series Stainless Steel ⁽¹⁾					Alloy Steel ⁽²⁾	300 Series SS
Balance Class:	AGMA 7	N/A	AGMA 8	N/A	AGMA 8	N/A	AGMA 9
Dynamic Balance:	Optional	Per TBW Commercial Standard	Optional	Per TBW Commercial Standard	Optional	N/A	Optional

(1) Stainless Steel is standard. Alloy Steel is optional.

(2) Alloy Steel is standard. Stainless Steel is optional.

Form-Flex® Disc Coupling Advantages

- Over 40 years experience in flexible disc couplings
- All metal Construction
- No Lubrication
- No Moving Parts
- Long Life
- High Torsional Stiffness
- Precise Positioning - Zero Backlash

Applications

Flexible Disc couplings can be used in a wide variety of applications from general industrial equipment to high speed precision machines. They are one of the most versatile coupling designs and can be customized to meet the demands of almost every application. Some of the applications in which Flexible Disc couplings can be used are:

- General Purpose & API610 Pumps
- Centrifugal & Screw Compressors
- Reciprocating Compressors
- Fans & Blowers
- Food Processing
- Machine Tools
- Cooling Towers
- Printing Presses
- Engine & Electric Motor Driven Applications
- Power Generation

Coupling Application Types Table

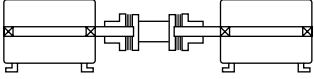
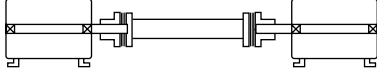
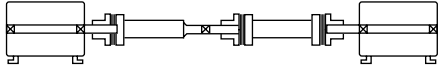
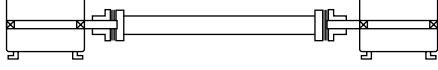
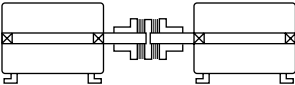
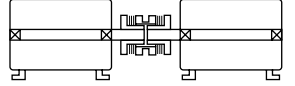
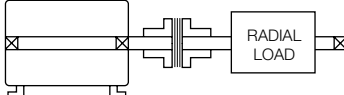
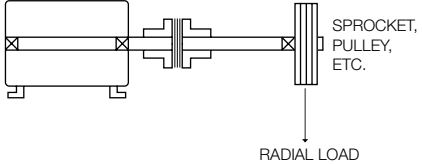
Coupling Type	Typical Applications	Series
<p>Spacer Couplings Double Flex</p>	<p>Spacer couplings are used to connect fully supported shafts with wider separations than can be reached with a close couple design. Spacer couplings allow room for installation and maintenance without moving the connected equipment. Shaft separations are generally in the range of 3 to 12 inches. These couplings accommodate angular, parallel and axial misalignment.</p>	 <p>AP, GP, TFI, GCF, GCH, FSH, HSH</p>
<p>Floating Shaft Coupling</p>	<p>Floating shaft couplings are spacer style couplings which are designed to connect widely separated shafts. The coupling spacers are fabricated. Both steel and TrueTube composite tubing options are available.</p> <p>Semi-floating shaft couplings are a special single flex version of the floating shaft coupling. These may be used alone for some applications or in combination with floating shaft couplings and pillow block bearings to span long distances.</p> <p>Composite floating shaft couplings should be considered as an alternative to multiple span applications with center bearings.</p>	   <p>A5, A5C, G5, B5C</p>
<p>Close Couple Double Flex</p>	<p>Close couple designs accommodate angular, parallel and axial misalignment types where two fully supported shafts are located very close together. Close shaft separations are generally in the range of 1/8 to 2 inches.</p>	  <p>AA, AX, AY</p>
<p>Single Flex</p>	<p>Single flexing couplings compensate for angular and axial misalignment only. Single couplings should only be used in a three bearing system with a self-aligning bearing as shown in the illustration. Single couplings may also be used in pairs to support a clutch, transducer or other system component. These arrangements are double flexing and must be used with two fully supported shafts as described below.</p>	  <p>AR, GR</p>

Coupling Selection Process

1) Select correct Service Factor (S.F.) from the chart below.

2) Calculate HP/100 RPM or Design Torque (lb-in).

$$\text{HP/100 RPM} = \frac{\text{HP} \times \text{S.F.} \times 100}{\text{coupling RPM}}$$

OR

$$\text{Design Torque (lb-in)} = \frac{63025 \times \text{HP} \times \text{S.F.}}{\text{coupling RPM}}$$

OR

$$\text{Design Torque} = \text{Torque (lb-in)} \times \text{S.F.}$$

Calculate kW/100 RPM or Design Torque (Nm)

$$\text{kW/100RPM} = \frac{\text{kW} \times \text{S.F.} \times 100}{\text{coupling RPM}}$$

$$\text{Design Torque (Nm)} = \frac{9550 \times \text{kW} \times \text{S.F.}}{\text{coupling RPM}}$$

$$\text{Design Torque} = \text{Torque (Nm)} \times \text{S.F.}$$

3) Compare this to the HP/100 RPM (kW/100 RPM) column or the Rated Torque column.

4) Check other limiting factors such as max bores, minimum DBSE, max speed and overall dimensions.

Unit Conversions: HP x .746 = kW or kW x 1.34 = HP

Nm x 8.851 = lb-in or lb-in x .113 = Nm

SERVICE FACTOR TABLE

These service factors assume a smooth motor or turbine type driver. The adders listed for other driver types must be added to the service factor shown for the driven equipment.







Adders For Driver Type		Driven Equipment	S.F.	Driven Equipment	S.F.	Driven Equipment	S.F.
DRIVER	ADD	CONVEYORS-Uniform load (Cont.)		FANS		PAPER MILLS-(Cont.)	
TURBINE	0	Flight	1.25	Centrifugal	1.00	Couch	1.75
AC MOTORS		Oven	1.50	Cooling Tower	2.00	Cutters, Platers	2.00
With Soft Start	0	Screw	1.25	FEEDERS		Cylinders	1.75
NEMA A or B, IEC N	0	CONVEYORS-Non-Uniform Load		Apron	1.25	Dryers	1.75
NEMA C or D, IEC H	1	Apron	1.50	Belt	1.25	Felt Stretchers	1.25
DC MOTORS		Assembly	1.25	Disc	1.25	Felt Whipper	2.00
Shunt Type	0	Belt	1.25	Reciprocating	2.50	Presses	2.00
Series or Compound	1	Bucket	1.50	Screw	1.25	Reel	1.50
I/C ENGINES		Chain	1.50	FOOD INDUSTRY		Stock Chests	1.50
8 or More Cylinders	1	Flight	1.50	Cereal Cookers	1.25	Suction Roll	1.75
4-6 Cylinders	1.5	Oven	1.50	Dough Mixers	1.75	Washers and Thickeners	1.50
1-3 Cylinders	2	Reciprocating	2.50	Meat Grinders	1.75	Winders	1.50
Driven Equipment	S.F.	Screw	1.50	Slicers	1.75	PRINTING PRESSES	1.50
AGITATORS		Shaker	2.50	LUMBER INDUSTRY		PUMPS	
Pure Liquids	1.00	CRANES AND HOISTS		Barkers-Drum Type	2.00	Centrifugal	1.00
Liquids and Solids	1.25	Main Cranes	2.00	Edger Feeders	2.00	Reciprocating	
Liquids-Variable Density	1.25	Reversing	2.00	Live Rolls	2.00	Double Acting	2.00
BLOWERS		Skip Hoists	1.75	Log Haul	2.00	Single Acting 1-2 Cylinders	2.25
Centrifugal	1.00	Trolley Drive	1.75	Off Bearing Rolls	2.00	Single Acting 3+ Cylinders	1.75
Lobe	1.50	Bridge Drive	1.75	Planers	1.75	Rotary-Gear, Lobe, Vane	1.50
Vane	1.25	Slope	1.50	Slab Conveyors	1.50	TEXTILE INDUSTRY	
BRIQUETTER MACHINE	1.00	DREDGES		Sorting Table	1.50	Batchers	1.25
CAN FILLING MACHINE	1.00	Cable Reels	1.75	Trimmer Feed	1.75	Calenders	1.75
COMPRESSORS		Conveyors	1.50	MACHINE TOOLS		Card Machines	1.50
Centrifugal	1.25	Maneuvering Winches	1.75	Bending Roll	2.00	Cloth Finishing Machines	1.50
Lobe	1.50	Pumps	1.75	Plate Planer	1.50	Dry Cans	1.75
Reciprocating	C/F	Screen Drives	1.75	Spindle Drives	1.50	Dryers	1.50
CONVEYORS-Uniform Load		Stracers	1.75	Table/Axis Drives	1.25	Dyeing Machinery	1.25
Apron	1.25	Utility Winches	1.50	Tapping Machines	2.50	Looms	1.50
Assembly	1.00	ELEVATORS		PAPER MILLS		Mangles	1.25
Belt	1.00	Bucket	1.75	Beater & Pulper	1.75	Nappers	1.25
Bucket	1.25	Centrifugal Discharge	1.50	Bleacher	1.00	Soapers	1.25
Chain	1.25	Freight	2.00	Calendars	2.00	Spinners	1.50
		Gravity Discharge	1.50	Converting Machines	1.50	Tinter Frames	1.50

Coupling Selection Guide

- 1) Consult factory for applications in shaded areas.
- 2) Torque ratings may vary by coupling series.
- 3) Use the 1.0 service factor column if a service factor was used in the HP/100 RPM calculation.

Consult Altra Couplings Engineering

Not Recommended for these Applications

Typical Application Conditions						
SMOOTH MOTOR OR TURBINE DRIVEN 	STEADY MOTOR OR TURBINE DRIVEN 	MODERATE MOTOR OR TURBINE DRIVEN 	MEDIUM MOTOR OR TURBINE DRIVEN 	HEAVY-HIGH TQ. MOTOR OR ENGINE DRIVEN 	EXTRA HEAVY ENGINE DRIVEN 	EXTREMELY HEAVY ENGINE DRIVEN 
SOFT START WITH STEADY LOAD	AVERAGE STARTING LOADS AND SLIGHT TORQUE VARIATIONS	ABOVE AVERAGE STARTING LOADS AND MODERATE LOAD VARIATIONS	HIGH STARTING TORQUES AND MEDIUM TO HEAVY LOAD VARIATIONS	MILD SHOCK LOADING ENGINES. DRIVING SMOOTH LOADS. EXTREME RELIABILITY	HEAVY SHOCK LOADING OR LIGHT REVERSING	EXTREME SHOCK LOADING. FREQUENT WIDE TORQUE VARIATIONS

Type/Size	Torque Rating				O.D. (in)	Service Factor						# of Bolts				
	HP / 100 RPM	Max Continuous (lb-in)	Peak Overload (lb-in)	Rated HP/100 RPM at Service Factor Shown												
				1.0		1.5	2.0	2.5	3.0	3.25	4.0					
Form-Flex® A-Series	05	0.48	300	600	2.65	0.48	0.32	0.24	0.19				4			
	10	1.27	800	1,600	3.19	1.27	0.85	0.63	0.51							
	15	2.50	1,575	3,150	3.65	2.50	1.67	1.25	1.00							
	20	3.49	2,200	4,400	4.08	3.49	2.33	1.75	1.40							
	25	6.03	3,800	7,600	4.95	6.03	4.02	3.01	2.41							
	30	11.00	6,930	13,860	5.63	11.00	7.33	5.50	4.40							
Form-Flex® G-Series	35	18.00	11,340	22,680	6.63	17.99	12.00	9.00	7.20				6			
	311	17.5	11,000	22,000	5.88	17.45	11.64	8.73	6.98					5.8	5.4	
	321	32.5	20,500	41,000	6.38	32.53	21.68	16.3	13.0					10.8	10	
	332	50.8	32,000	64,000	7.20	50.8	33.8	25	20					17	16	
	346	73.0	46,000	92,000	8.20	73.0	48.7	36	29					24	22	
	380	127	80,000	160,000	9.36	127	85	63	51					42	39	
	340	63.5	40,000	80,000	8.38	63.5	42.3	32	25					21	20	16
	412	190	120,000	240,000	11.00	190	127	95	76					63	59	48
	419	301	190,000	380,000	12.50	301	201	151	121					100	93	75
	424	476	300,000	600,000	15.00	476	317	238	190					159	146	119
	444	690	435,000	870,000	16.38	690	460	345	276					230	212	173
	456	889	560,000	1,120,000	18.00	889	592	444	355					296	273	222
	483	1317	830,000	1,660,000	19.44	1317	878	658	527					439	405	329
	511	1745	1,100,000	2,200,000	22.00	1745	1164	873	698					582	537	436
520	3173	2,000,000	4,000,000	24.88	3173	2116	1587	1269	1058	976	793					
525	3967	2,500,000	5,000,000	26.75	3967	2644	1983	1587	1322	1221	992					
530	4760	3,000,000	6,000,000	28.00	4760	3173	2380	1904	1587	1465	1190					
540	6347	4,000,000	8,000,000	33.50	6347	4231	3173	2539	2116	1953	1587					
Torsiflex-i TFI	17	2.4	1,504	2,632	2.87	2.39	1.59	1.19	0.95	0.80	0.73				6	
	27	3.8	2,390	4,183	3.35	3.79	2.53	1.90	1.52	1.26	1.17					
	38	5.3	3,363	5,885	4.21	5.34	3.56	2.67	2.13	1.78	1.64					
	140	19.7	12,391	21,684	5.00	19.66	13.1	9.83	7.86	6.6	6.0					
	260	36.5	23,031	40,304	6.06	36.54	24	18.3	14.6	12	11					
	400	56.2	35,404	61,957	6.93	56.2	37	28	22	19	17					
	750	105	66,383	116,170	7.99	105	70	53	42	35	32					
	1310	184	115,948	202,909	9.49	184	123	92	74	61	57					
	1900	267	168,169	294,296	10.98	267	178	133	107	89	82					
	2500	351	221,275	387,231	11.65	351	234	176	140	117	108					
	3300	463	292,083	511,145	12.84	463	309	232	185	154	143					
	6000	843	531,060	929,355	15.55	843	562	421	337	281	259					
	8500	1194	752,335	1,316,586	17.44	1194	796	597	477	398	367					
12000	1685	1,062,120	1,858,710	19.45	1685	1123	843	674	562	519						
Form-Flex® (HSH/FSH)	22	15.1	9,500	14,250	6.00	15.07	10.05	7.54	6.03	5.02	4.64	3.8				8
	26	25.4	16,000	24,000	6.87	25.39	16.9	12.7	10.2	8.5	7.8	6				
	31	38.1	24,000	36,000	8.12	38.08	25	19.0	15.2	13	12	10				
	35	69.8	44,000	66,000	9.12	69.8	47	35	28	23	21	17				
	37	95.2	60,000	90,000	10.06	95.2	63	48	38	32	29	24				
	42	116	73,000	109,500	11.00	116	77	58	46	39	36	29				
	45	157	99,000	148,500	11.44	157	105	79	63	52	48	39				
	50	203	128,000	192,000	13.00	203	135	102	81	68	62	51				
	55	300	189,000	283,500	15.00	300	200	150	120	100	92	75				
	60	414	261,000	391,500	16.00	414	276	207	166	138	127	104				
	70	658	415,000	622,500	18.50	658	439	329	263	219	203	165				
	75	846	533,000	799,500	20.00	846	564	423	338	282	260	211				
	80	1087	685,000	1,027,500	22.00	1087	725	543	435	362	334	272				
	85	1315	829,000	1,243,500	23.75	1315	877	658	526	438	405	329				
	92	1650	1,040,000	1,560,000	25.75	1650	1100	825	660	550	508	413				
92HT	2221	1,400,000	2,100,000	25.75	2221	1481	1111	889	740	683	555					

Standard Bore Tolerances

Imperial Standard Bore and Keyway Info

Recommended Bore Tolerance for Imperial Shafts (Inches)

Nominal Shaft Range		Shaft Tol.	Interference Fit Bore Tol.	Clearance Fit Bore Tol.
Over	To (Incl.)			
.4375	1.5	+.0000 / -.0010	-.0005 / -.0010	+.0010 / -.0000
1.5	2		-.0010 / -.0020	+.0010 / -.0000
2	3		-.0010 / -.0020	+.0015 / -.0000
3	4		-.0015 / -.0030	
4	5		-.0020 / -.0035	
5	7		-.0025 / -.0040	
7	8		-.0030 / -.0050	N/A
8	9		-.0035 / -.0055	N/A
9	10		-.0040 / -.0060	N/A

Reference AGMA 9002-B04

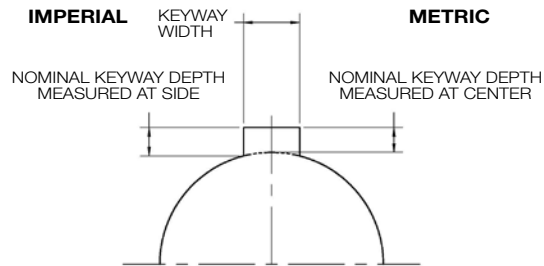

Recommended Hub Keyway Dimensions (Inches)

Nominal Bore Range		Key Dims.		
Over	To (Incl.)	Width	Depth Square Key	Depth Reduced Key
0.312	0.438	0.094	0.047	-
0.438	0.562	0.125	0.063	0.047
0.562	0.875	0.188	0.094	0.062
0.875	1.250	0.25	0.125	0.094
1.250	1.375	0.312	0.156	0.125
1.375	1.750	0.375	0.188	0.125
1.750	2.250	0.500	0.250	0.188
2.250	2.750	0.625	0.313	0.219
2.750	3.250	0.750	0.375	0.250
3.250	3.750	0.875	0.438	0.313
3.750	4.500	1.000	0.500	0.375
4.500	5.500	1.250	0.625	0.438
5.500	6.500	1.500	0.750	0.500
6.500	7.500	1.750	0.875	0.750
7.500	9.000	2.000	1.000	0.750
9.000	11.000	2.500	1.250	0.875

Standard keyway fit is Commercial Class per AGMA 9002-B04

Metric Standard Bore and Keyway Info

Recommended Bore Tolerance for Metric Shafts (mm)

Nominal Shaft Range		Shaft Tol.	Shaft Des.	Clearance Fit		Interference Fit	
Over	To (Incl.)			Bore Tol.	Bore Des.	Bore Tol.	Bore Des.
12	18	+.008 / -.003	j6	+.016 / +.034	F7	-.015 / -.004	M6
19	30			+.020 / +.041	F7	-.017 / -.004	M6
32	50	+.018 / +.002	k6	+.025 / +.050	F7	-.013 / +.003	K6
55	80			+.030 / +.060	F7	-.021 / +.009	K7
85	100	+.035 / +.013	m6	+.036 / +.071	F7	-.035 / +.000	M7
110	120					+.035 / +.013	-.059 / -.024
125	180	+.040 / +.015		+.043 / +.083	F7	-.068 / -.028	P7
190	200			+.046 / +.017	+.050 / +.096	F7	-.079 / -.033
210	225	-.109 / -.063					R7
230	250	-.113 / -.067					R7
260	280	+.052 / +.020		+.056 / +.108	F7	-.126 / -.074	R7

Reference AGMA 9112-A04

Recommended Hub Keyway Dimensions (mm)

Nominal Bore Range		Nominal Key Size	Hub Keyway		
Over	To (Incl.)		Width	Depth	
				Nominal	Nominal
10	12	4X4	4	1.8	
12	17	5X5	5	2.3	
17	22	6X6	6	2.8	
22	30	8X7	8	3.3	
30	38	10X8	10	3.3	
38	44	12X8	12	3.3	
44	50	14X9	14	3.8	
50	58	16X10	16	4.3	
58	65	18X11	18	4.4	
65	75	20X12	20	4.9	
75	85	22X14	22	5.4	
85	95	25X15	25	5.4	
95	110	28X16	28	6.4	
110	130	32X18	32	7.4	
130	150	36X20	36	8.4	
150	170	40X22	40	9.4	
170	200	45X25	45	10.4	
200	230	50X28	50	11.4	
230	260	56X32	56	12.4	
260	290	63X32	63	12.4	

Standard metric keyway width tolerance per Js9

Engineering Standards

INDUSTRY STANDARDS REFERENCED

AGMA 9002-B04 - BORES AND KEYWAYS FOR FLEXIBLE COUPLINGS (INCH SERIES)
 AGMA 9112-A04 - BORES AND KEYWAYS FOR FLEXIBLE COUPLINGS (METRIC SERIES)
 AGMA 922-A96 - LOAD CLASSIFICATION AND SERVICE FACTORS FOR FLEXIBLE COUPLINGS
 API610 / ISO 13709 - CENTRIFUGAL PUMPS FOR PETROLEUM, PETROCHEMICAL AND NATURAL GAS INDUSTRY, 11th Edition - Torsiflex-i meets the requirements of API610, 11th Edition when supplied with interference fit bores.
 API671 / ISO 10441 - SPECIAL PURPOSE COUPLINGS FOR PETROLEUM, CHEMICAL AND GAS INDUSTRY SERVICES, 4th Edition
 NEMA MG1 14.38, MG1 20.81 AND MG1 21.82 - All Form-Flex® & Torsiflex-i flexible disc couplings meet these standards without the addition of a limited end float device.

Certain tables and data in this catalog were extracted from the reference AGMA standards with the permission of the publisher, the American Gear Manufacturers Associations, 1901 North Meyer Drive, Arlington, VA 22209.

DYNAMIC BALANCING RECOMMENDATIONS

Use this graph to determine the appropriate balance class based on coupling weight and operating speed. The balance classes listed on the graph are for equipment with average sensitivity to coupling unbalance. The user should determine how sensitive the equipment train is to coupling unbalance. Use one balance class higher if your system has higher than average sensitivity to unbalance. Use one balance class lower if your system has lower than average sensitivity to unbalance. Use this guide to check your coupling selection against the recommended balance class for your operating conditions.

The following factors should be considered when determining a machine's sensitivity to coupling unbalance.

- 1) Shaft End Deflection: Machines having flexible shaft extensions are relatively sensitive to coupling unbalance.
- 2) Bearing Load Due to Coupling Weight Relative to Total Bearing Load: Machines having lightly loaded bearings, bearings that are primarily loaded by the weight of the coupling or other overhung weight are relatively sensitive to coupling unbalance.
- 3) Bearing, Bearing Support and Foundation Flexibility: Machines or systems with flexible foundations for supports for the rotating elements are relatively sensitive to coupling unbalance.
- 4) System Natural Frequencies: Machines operating at or near natural frequencies are sensitive to coupling unbalance.
- 5) Machine Separation: System having widely separated machines are relatively sensitive to coupling unbalance.
- 6) Shaft Extension Relative to Bearing Span: Machines having a short bearing span relative to their shaft extensions are sensitive to static unbalance.

BALANCE CLASS SELECTION CHART

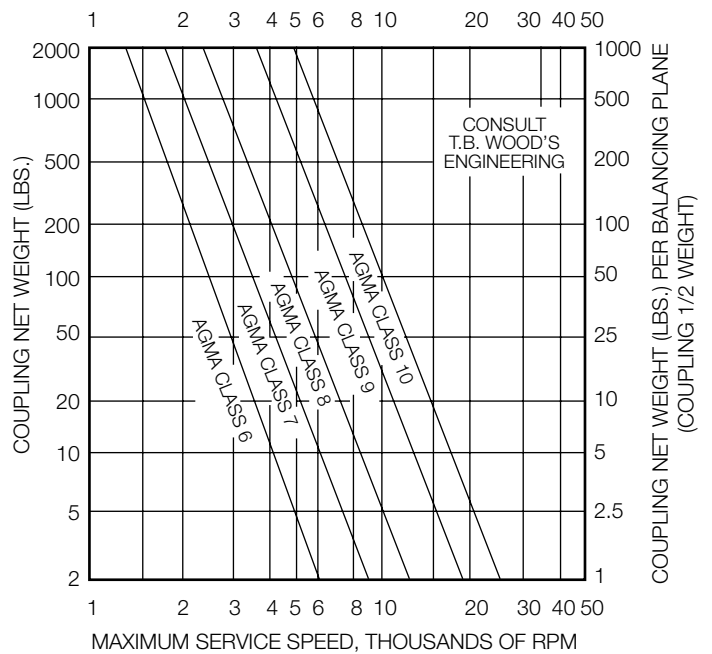

HOW FLEXIBLE DISC COUPLINGS ACCOMMODATE MISALIGNMENT

Double flexing metal disc couplings may be used to accommodate angular, parallel and axial misalignment. Single flexing couplings may only be used to accommodate angular and axial misalignment. A metal disc type coupling uses a double hinge effect through two flexible discs and the spacer to compensate for parallel offset misalignment between shafts. Parallel misalignment imposes the same angular deflection (A) on each flex disc. Angular misalignment of either connected shaft, (B), creates additional angular deflections which are added to the angular offset due to parallel misalignment. The total misalignment angle, (C), at the flex disc is equal to the angular offset due to parallel misalignment (A) plus the angular offset due to angular misalignment (B). The maximum misalignment angle (C) should never exceed the rated misalignment capacity of the coupling type being used. Machinery equipment changes in actual operation and over the life of the equipment. We recommend that the machinery misalignment be set as close to zero as possible when a coupling is installed. We recommend keeping the measured misalignment below 25% of the rated misalignment capacity of the coupling type used when the machinery is installed and aligned. The remaining coupling misalignment capacity will then be available to accommodate additional misalignment caused by foundation shifts, vibrations, thermal growth or other causes.

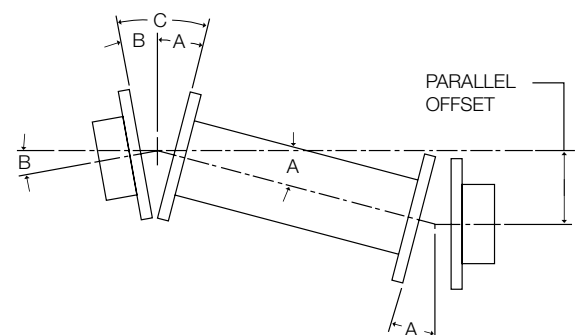

Product Differentiation

Form-Flex® A - Series	Form-Flex® G - Series	Torsiflex-i TFI - Series
Higher bore capacity in low torque range	Higher Torque Density	Higher Torque Density and large bore capacity
1 ° Misalignment	.3 - .5 ° Misalignment	.3 - .5 ° Misalignment
Clearance Fit is standard	Interference Fit is standard	Interference Fit is standard
AGMA 7 balance class	AGMA 8 balance class	AGMA 9 balance class
Non-Unitized Flex Pack	Unitized Flex Pack	Factory assembled Transmission Unit
ATEX Group II/ Cat 3	ATEX Group II/ Cat 3	ATEX Group II/ Cat 2 Anti-Sparking design is standard
Low to Moderate Speeds	Low to Moderate Speeds	High to Moderate speeds

DISC PACK DESIGN COMPARISON

**Form-Flex® G-Series
Sizes 311-380**

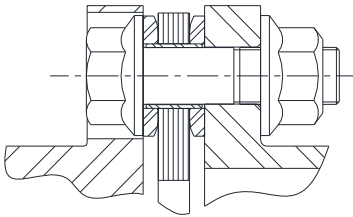

UNITIZED

- Disc pack force transferred to washer & hub interface
- Low bolt bending stress
- All torque transmitted through friction
- Higher torque capacity

**Form-Flex® G-Series
Sizes 340 & 412-511**

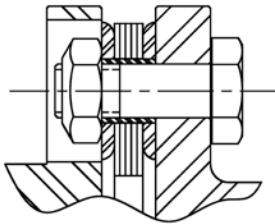

**Form-Flex® G-Series
Sizes 517-540**

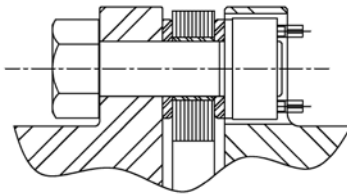

**Form-Flex®
A-Series
Sizes 5-35**

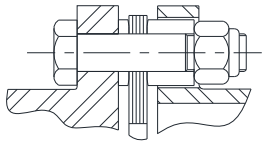

**Form-Flex®
HSH/FSH**

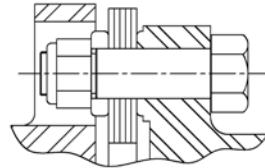

NON-UNITIZED

- Disc pack creates a bending moment on bolt
- High bolt bending stress
- Torque transmitted through shear and friction
- Lower torque capacity

UNITIZED DISC DESIGNS

**Form-Flex®
G-Series, Sizes 311-380
(excluding 340)**

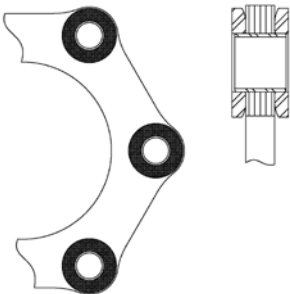

**Form-Flex®
G-Series, Sizes 340 & 412-540**

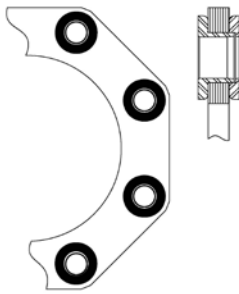

NON-UNITIZED DISC DESIGNS

**Form-Flex®
A-Series sizes 5-35**

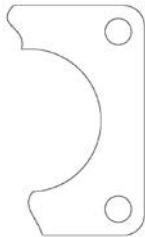

**Torsiflex-i
Sizes 27-1310**

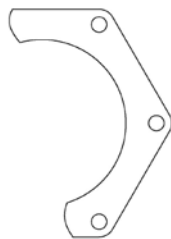

**Torsiflex-i
Sizes 1900-1200**



**Form-Flex®
HSH/FSH**

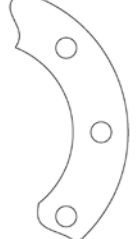

Spacer Couplings

PRODUCT DESCRIPTION

- Designed for moderate to higher speed applications
- Construction includes:
 - Two fully machined steel hubs
 - One fully machined steel spool spacer
 - Standard hardware and stainless steel disc packs
- Form-Flex® A-Series designs use non-unitized disc packs
- Form-Flex® G-Series designs use unitized disc packs
- Torsiflex-i designs use a drop out transmission unit with non-unitized disc packs
- Custom length spacer up to max DBSE
- Balancing and other modifications to suit your special system requirements
- Can be bored for any shaft configuration (F5-40 for hub design options)



TYPICAL APPLICATIONS

- Pumps
- Centrifugal and Screw Compressors
- Fans and Blowers
- Mixers
- Turbo Compressors

SPECIAL APPLICATIONS

- Test Stands
- Machine Tools / Positioning Systems
- Electrical Insulation

Spacer Coupling AP Series - Form-Flex®

Double Flex Spacer

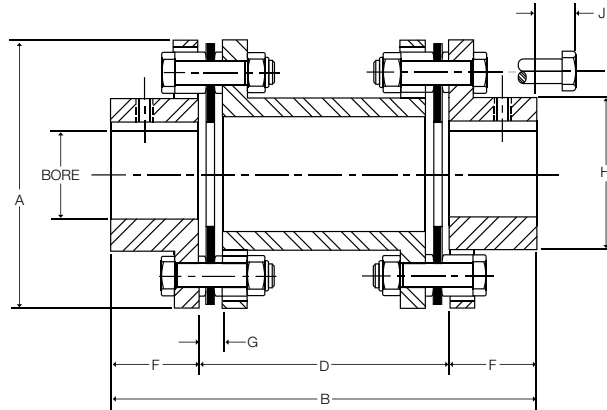

COUPLING CAN BE SUPPLIED TO API610 11TH EDITION

Size	Max Bore				Dimensions (in)								
	AJ		AZ		A	B		D DBSE		F	G	H	J
	(in)	(mm)	(in)	(mm)		Min	Max	Min	Max				
5	0.875	22	1.19	30	2.65	3.72	6.94	1.72	4.94	1.00	0.24	1.30	0.54
10	1.250	33	1.63	43	3.19	4.06	7.00	2.06	5.00	1.00	0.27	1.80	0.56
15	1.375	36	1.75	48	3.65	4.67	8.89	2.41	6.63	1.13	0.32	2.00	0.88
20	1.688	46	2.13	58	4.08	5.02	9.27	2.38	6.63	1.32	0.34	2.40	0.79
25	2.000	53	2.56	68	4.95	6.16	13.12	2.92	9.88	1.62	0.45	2.80	1.00
30	2.380	63	2.88	79	5.63	7.57	13.70	3.81	9.94	1.88	0.47	3.30	1.14
35	2.938	80	3.75	101	6.63	8.81	17.56	4.31	13.06	2.25	0.55	4.15	0.97

Dimensions are shown for standard AJ hubs unless otherwise specified.

Size	HP/100 RPM	Rated Torque (lb-in)	Peak O/L Torque (lb-in)	AGMA 7 Max RPM	Weight (lbs) (1)		WR ² (lb-in ²) (1)		Misalignment Capacity	
					at D Min	Add Per Inch of D	at D Min	Add Per Inch of D	Axial (+/-in)	Angular (Degrees/Disc Pack)
5	0.48	300	600	8,500	2.32	0.14	1.87	0.05	0.030	1°
10	1.27	800	1,600	7,500	3.62	0.22	4.48	0.11	0.040	
15	2.5	1,575	3,150	6,700	5.44	0.26	8.86	0.19	0.042	
20	3.49	2,200	4,400	6,200	6.96	0.32	13.8	0.34	0.055	
25	6.03	3,800	7,600	5,500	12.7	0.41	38.8	0.62	0.060	
30	11	6,930	13,860	5,000	19	0.46	77.7	0.92	0.065	
35	18	11,340	22,680	4,400	27.6	0.63	156	2.29	0.085	

1) Weight and WR² values shown are for AJ hubs at max inch bore and spacer length at D Min

STANDARD MATERIALS (CLASS A)

HUBS - CARBON STEEL
 SPACER - CARBON STEEL
 HARDWARE - ALLOY STEEL
 DISC PACK - STAINLESS STEEL

MATERIAL / FINISH OPTIONS

CLASS A - Steel hubs and spacer, alloy steel hardware, 300 series stainless steel disc pack
 CLASS B - Zinc plated steel hubs, and spacer, alloy steel hardware, 300 series stainless steel disc pack
 CLASS C - Zinc plated steel hubs, and spacer, stainless steel hardware, 300 series stainless steel disc pack
 CLASS E - 300 series stainless steel hubs and spacer, stainless steel hardware, 300 series stainless steel disc pack
 (Only available for sizes 15 thru 35)

ORDERING

AP SERIES COUPLINGS ARE SOLD AS COMPONENTS
 COUPLINGS CONSIST OF:
 2 - HUBS - Example (AJ25A x 1-3/4")
 1 - SPACER SUB-ASSEMBLY - Example for DBSE = 5.00"
 (AP25A500)

Spacer Coupling GP Series - Form-Flex®

Double Flex Spacer

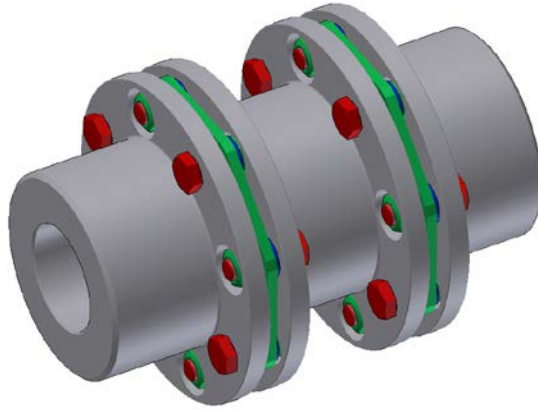

Size	Torque Rating			Max Speed (RPM)		Weight (lbs) (1)		WR ² (lb-in ²) (1)		Misalign-ment Capacity	
	HP / 100 (RPM)	Max Continuous (lb-in)	Peak Overload (lb-in)	AGMA 8	ABS. Max	at D Min	Add Per Inch of D	at D Min	Add Per Inch of D	Axial (+/- in)	Angular (Degrees/ Disc Pack)
311	17	11,000	22,000	5,400	13,000	16.20	0.62	66.70	2.09	0.028	0.5°
321	33	20,500	41,000	4,900	12,000	25.75	0.66	123.01	2.54	0.029	
332	51	32,000	64,000	4,400	11,500	40.27	0.94	242.39	4.27	0.030	
346	73	46,000	92,000	4,100	9,000	54.42	1.03	429.27	6.94	0.050	
380	127	80,000	160,000	3,800	7,000	79.30	1.20	792.67	8.75	0.080	
412	190	120,000	240,000	3,500	6,000	110.1	1.45	1607.6	13.29	0.080	0.33°
419	301	190,000	380,000	3,000	5,000	197.8	2.32	3660.0	27.92	0.100	
424	476	300,000	600,000	2,750	5,000	287.6	3.08	8127.6	62.49	0.100	
444	690	435,000	870,000	2,500	4,000	413.3	3.38	13587	87.03	0.110	
456	1015	640,000	1,280,000	2,350	3,500	539	4.73	21896	133.5	0.120	
483	1317	830,000	1,660,000	2,200	3,500	727	5.36	33653	195.1	0.130	
511	1904	1,200,000	2,400,000	2,050	3,000	978	6.75	60082	310.3	0.140	
520	3173	2,000,000	4,000,000	1,750	2,500	1752	10.14	114979	586.5	0.180	
525	3967	2,500,000	5,000,000	1,700	2,500	2113	11.07	185975	762.5	0.200	
530	4760	3,000,000	6,000,000	1,600	2,500	2533	15.43	243383	1160.9	0.200	
540	6347	4,000,000	8,000,000	1,450	2,000	3831	19.23	557906	2247.7	0.240	

1) Weight and WR² values shown are for standard hubs at max inch bore and spacer length at D Min

STANDARD MATERIALS

HUBS - CARBON STEEL

SPACER - CARBON STEEL

HARDWARE - ALLOY STEEL

DISC PACK - STAINLESS STEEL

MATERIAL / FINISH OPTIONS

DISC PACK - ALLOY STEEL (For cost reduction, available for sizes 412 to 540)

ZINC ELECTRO PLATING

ZINC PHOSPHATE COATING

ALLOY STEEL HUBS

Spacer Coupling GP Series - Form-Flex®

Double Flex Spacer

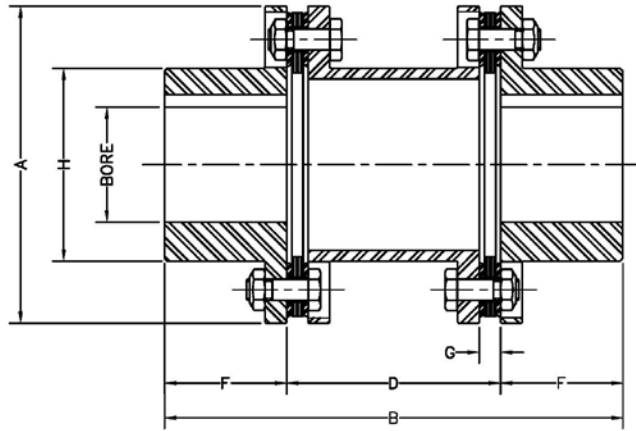

COUPLING CAN BE SUPPLIED TO API610 11TH EDITION

Size	Max Bore						Common Coupling Dimensions (in)								
	Standard Hub			Oversized/Large Hub			A	B		D DBSE		F	G	H	
	Square Key (in)	Rect. Key (in)	Rect. Key (mm)	Square Key (in)	Rect. Key (in)	Rect. Key (mm)		Min	Max	Min	Max			Std Hub	O/S Hub
311	2.813	3.063	78	3.125	3.313	86	5.88	8.06	17.75	3.06	12.75	2.50	0.40	3.91	4.30
321	3.000	3.250	83	3.250	3.438	90	6.38	10.13	19.06	4.13	13.06	3.00	0.55	4.25	4.57
332	3.188	3.313	87	3.438	3.688	95	7.20	11.00	19.19	5.00	13.19	3.50	0.61	4.50	4.95
346	3.750	4.000	107	4.250	4.500	117	8.20	11.00	25.19	5.00	19.19	3.75	0.62	5.42	5.95
380	3.750	4.000	105	4.250	4.500	118	9.36	15.00	28.00	6.75	19.75	4.13	0.89	5.65	6.30
412	4.500	4.500	120	4.750	5.125	135	11.00	14.19	27.94	5.69	19.44	4.25	0.75	6.51	7.20
419	4.500	4.875	130	5.500	5.625	150	12.50	17.69	29.94	7.69	19.94	5.00	0.98	7.32	8.07
424	6.625	6.880	190				15.00	20.19	32.44	7.69	19.94	6.25	0.98	9.57	
444	7.000	7.375	200				16.38	22.75	34.13	8.75	20.13	7.00	1.09	10.52	
456	8.000	8.000	220				18.00	24.31	35.13	9.81	20.63	7.25	1.32	11.63	
483	8.250	8.875	234				19.44	27.69	37.75	10.69	20.75	8.50	1.39	12.56	
511	10.000	10.125	280				22.00	29.69	39.06	11.69	21.06	9.00	1.56	14.50	
520	10.375	11.000	297				24.88	38.50	45.50	14.75	21.75	11.88	1.89	16.10	
525	11.000	12.000	322				26.75	39.38	45.88	15.38	21.88	12.00	1.95	17.35	
530	11.500	12.750	338				28.00	41.88	47.75	16.38	22.25	12.75	2.14	18.35	
540	15.750	17.000	448				33.50	49.00	54.13	19.00	24.13	15.00	2.58	22.63	

ORDERING

GP SERIES COUPLINGS ARE SOLD AS COMPLETE ASSEMBLIES
PLEASE SPECIFY BORE SIZES, DISC PACK MATERIAL AND DBSE.
A COUPLING WILL BE CONFIGURED TO MEET YOUR SPECIFICATIONS.

Pump Spacer Coupling TFI Series - Torsiflex-i

API610/ISO13709 | Double Flex Spacer

Torsiflex-i Disc Couplings Specifically designed for the process pump and general industrial markets.

The TFI coupling is specifically designed for the process pump and general industrial applications. It is comprised of two fully machined steel hubs, and a factory assembled drop out transmission unit. Standard spacer lengths are stock or it can be ordered for any custom spacing. This coupling is suitable for moderate to high speed operation on a wide range of general purpose motor and turbine driven equipment, including pumps, compressors and fans.



Advantages

- Standard coupling is fully compliant with the requirements of API610/ISO13709 & ISO14691
- Max bores matched to NEMA motor shafts, resulting in up to 60% weight savings per application
- Smaller diameter and lower weight per HP provide better inherent balance
- Plug-in spacer design allows installation and removal without disturbing the hubs
- Robust disc pack design allows for greater torque load in a smaller coupling, resulting in lower weight
- Large bolts for high clamp load, increasing frictional torque load, and reduced bolt bending stress
- ATEX compliance is standard — ExII 2GDc135degC(T4)
- Built-in Anti-Flail Feature
- Large hubs available on first three sizes
- Compliance with API 671/ISO 10441 is available

Standard Materials

Hubs - Carbon Steel
Adapters - Carbon Steel
Spacer - Carbon Steel
Disc Pack - Stainless Steel
Hardware - Alloy Steel
O/L Washers - High Strength
“Non-Sparking” Material

Standard Finish

Zinc phosphate coating on hubs, spacers and adapters.

Features

- Torsiflex-i couplings consist of 2 hubs and a factory assembled transmission unit. Installation involves fitting the hubs to the machinery shaft ends, introducing the transmission unit, then securing with the attachment screws
- MAXIMUM SPEEDS shown are for standard materials. When higher speeds are required please consult TB Woods Engineering.
- AGMA 9 BALANCE CLASS is met when hubs are bored for interference fit.
- PEAK TORQUE of 1.75 and MOMENTARY TORQUE of 2.7 times the stated ratings are accepted
- SPARK FREE overload protection is provided as a standard feature on all Torsiflex-i couplings, making them suitable for GAS ZONE environments
- STANDARD COUPLINGS are designed for general purpose applications and are suitable for the majority of process pump, fan, and compressors applications
- SPECIAL COUPLING versions available include:
 - Torque overload protection
 - Limited end float
 - Electrical Insulation
 - Bolted adapters suitable for high cyclic torques

Material / Finish Options

Disc Pack - Inconel
Zinc Electro Plating
Alloy Steel Hubs
Welded Tube Spacer for Longer Spans

Pump Spacer Coupling TFI Series - Torsiflex-i

API610/ISO13709 | Double Flex Spacer

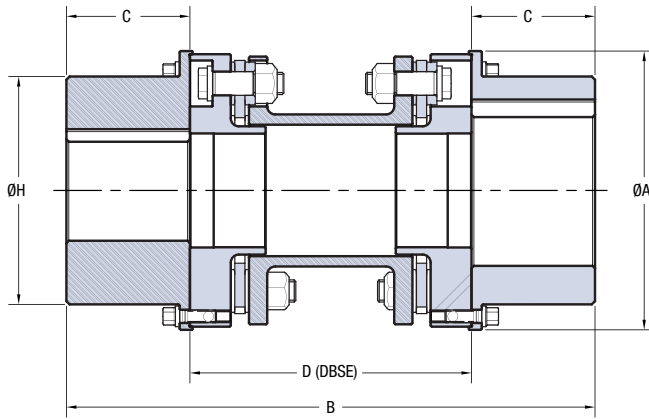

Standard Torsiflex-i Coupling

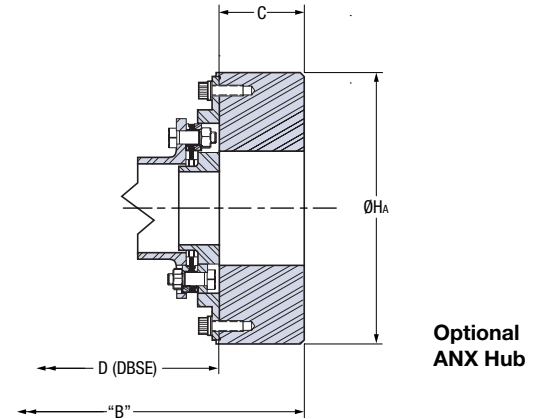

Optional ANX Hub

Size	Coupling Dimensions (in)						Max Bore						Stock Spacer Length (in) ⁽²⁾							
	A	B	C	H	HA	Min DBSE ⁽¹⁾	Square Key			Reduced Key			3.50	4.38	5.00	5.50	7.00	7.50	8.00	9.00
							Standard Hub (in)	Large Hub (in)	ANX Hub (in)	Standard Hub (in / [mm])	Large Hub (in / [mm])	ANX HUB (mm)								
27	3.35	5.91	1.57	2.143	4.776	2.76	1.56	2.25	3.00	1.69 [42]	2.25 [57]	82	S	S	S	S	S	O	O	O
38	4.21	6.30	1.77	2.891	5.647	2.76	2.19	3.00	3.75	2.25 [58]	3.00 [76]	104	S	S	S	S	S	O	O	O
140	5.00	9.84	2.95	3.757	6.526	3.94	2.75	-	4.50	2.94 [75]	-	121		S	S	S	S	O	O	O
260	6.06	11.42	3.35	4.662	7.589	4.72	3.44	-	5.25	3.69 [95]	-	145			S	S	S	O	O	O
400	6.93	13.78	4.13	5.568	8.874	5.51	4.19	-	6.00	4.50 [116]	-	165					S	S	S	O
750	7.99	16.14	4.72	6.46	10.09	6.69	4.63	-	6.50	5.00 [132]	-	192					S	S	S	O
1310	9.49	19.29	5.71	7.76	11.567	7.87	5.63	-	7.50	6.13 [162]	-	226							S	S
1900	10.98	19.69	5.91	9.17	13.064	7.87	6.75	-	9.00	7.00 [192]	-	260							S	S
2500	11.65	21.57	6.46	9.45	13.733	8.66	6.88	-	9.50	7.13 [197]	-	276								S
3300	12.84	23.78	7.17	10.63	-	9.45	7.63	-	-	8.25 [220]	-	-								
6000	15.55	28.35	9.06	12.68	-	10.24	9.00	-	-	9.88 [265]	-	-								
8500	17.44	33.07	10.24	14.37	-	12.60	10.63	-	-	11.25 [302]	-	-								
12000	19.45	36.38	11.50	16.02	-	13.39	11.50	-	-	12.75 [337]	-	-								

* For Large Hub H = A

(1) The inclusion of additional features such as packing rings, shims and/or electrical insulation will increase the minimum DBSE (Distance Between Shaft Ends)

(2) S = Stocked length ; O = Optional length

Size	Torque Rating		Max Speed RPM	Weight Transmission Unit (lb)			Weight Unbored Hub (lb) (3)			Angular Misalignment	Axial Deflection (in)
	HP / 100 RPM	(lb-in)		Mass @ Min DBSE	ANX Adder Per End	Extra Per (inch)	Standard	Large	ANX		
27	3.79	2,390	20,000	3.0	0.443	0.17	1.9	3.80	7.5	.5°	0.019
38	5.34	3,363	16,500	4.3	0.497	0.25	3.81	6.75	12		0.019
140	19.7	12,391	12,000	10.1	0.638	0.39	9.76	-	32.9		0.019
260	36.5	23,013	10,000	17.2	0.724	0.57	16.94	-	56.8		0.024
400	56.2	35,404	8,500	28.4	1.73	0.80	29.63	-	91.5		0.055
750	105	66,383	7,500	46.7	3.821	1.26	46.1	-	140.3		0.071
1310	184	115,948	6,500	80.7	3.948	1.49	80.2	-	213.7		0.087
1900	267	168,169	5,600	100	-5.178	1.84	109	-	310	.33°	0.059
2500	351	221,275	5,200	132	-6.983	2.24	133	-	375.5		0.067
3300	463	292,083	4,900	179	-	2.73	186	-	-		0.071
6000	843	531,060	4,000	273	-	4.10	333	-	-		0.094
8500	1194	752,335	3,600	439	-	5.39	485	-	-		0.11
12000	1685	1,062,120	3,000	569	-	6.64	686	-	-	0.118	

(3) For Finish Bore Hub weight = Weight Unbored hub - .222 * Hub Length * Bore Dia.^2

ORDERING

TF SERIES COUPLINGS ARE SOLD AS COMPONENTS

COUPLINGS CONSIST OF:

2 - HUBS - Example (TFI0038 x 2.00 mm)

1 - TRANSMISSION UNIT - Example for DBSE = 5.00" (TFI0038SA500MM)

Pump Spacer Coupling TFI Series w/ Torsi-Lock - Torsiflex-i

API610/ISO13709 | Double Flex Spacer

- All Torsi-Lock devices must be sized to transmit the actual application Peak Torque. The data table shows a comparison of the Torsi-Lock torque transmissibility to the coupling Peak Torque Rating as a reference. The table below does not show all possible Torsi-Lock sizes and ranges. For any Torsi-Lock requirement beyond those detailed here, please consult TB Woods Engineering (see the catalog back cover for contact information).
- To determine the actual transmissible torque, as well as the actual combined hub plus Torsi-Lock device weight, from the data table, linearly interpolate between the range of values given for min and max shaft diameter. See the example interpolation calculation to the right.
- The data table is applicable to keyless shaft applications only. For keyed shaft applications, either:
 - Use a half key in the shaft and deduct the transmissible torque value of the Torsi-Lock by 10%
 - Use a full height key and the overkey dimension as the Shaft Size (dw) to determine the correct Torsi-Lock size.



Torsi-Lock Size				20	22	24	30	36	40	44	48	50	55	62	68	75	80	90	100	
Shaft Size Range	DW	Min (over)	in	0.630	0.709	0.787	0.827	1.024	1.220	1.339	1.417	1.575	1.654	1.890	2.047	2.362	2.559	2.756	2.953	
			mm	16	18	20	21	26	31	34	36	40	42	48	52	60	65	70	75	
		Max (incl)	in	0.709	0.787	0.827	1.024	1.220	1.339	1.417	1.575	1.654	1.890	2.047	2.362	2.559	2.756	2.953	3.150	
			mm	18	20	21	26	31	34	36	40	42	48	52	60	65	70	75	80	
Transmissible Torque (x1000)		TMin	lb-in	1.15	1.50	1.86	1.71	3.45	4.96	6.28	6.46	9.29	10.3	15.5	17.7	22.1	28.3	42.0	61.1	
		TMax	lb-in	1.59	2.04	2.21	3.36	5.58	7.08	7.61	9.82	12.2	16.6	19.9	27.9	35.0	40.7	64.2	79.7	
Torsi-Lock Device Dims	O.A.L.	L1	in	0.89	0.89	0.91	0.98	1.07	1.11	1.18	1.18	1.26	1.36	1.38	1.38	1.50	1.50	1.75	1.95	
	O.D.	Ht	in	1.89	1.89	1.97	2.36	2.83	2.95	3.15	3.15	3.54	3.94	4.33	4.53	5.43	5.71	6.10	6.69	
	Weight	Wt	lb	0.44	0.44	0.44	0.66	1.10	1.10	1.32	1.21	1.76	2.43	2.87	3.09	5.29	5.51	7.28	10.4	
Coupling Size	TFI0027			1.48	1.47	1.46	1.77	2.24	2.19	2.44	2.40	2.87	3.69							
	TFI0038			1.44	1.43	1.44	1.64	2.07	2.08	2.36	2.21	2.76	3.33							
	TFI0140			1.47	1.47	1.49	1.57	1.65	1.69	1.76	1.76	1.84	1.94							
	TFI0260								3.79	4.04	3.99	4.46	5.29	5.76	6.08	8.23	8.40	10.8	14.8	
	TFI0400								3.67	3.95	3.80	4.35	4.92	5.48	5.47	7.78	7.91	10.2	14.1	
	TFI0750								1.69	1.76	1.76	1.84	1.94	1.96	1.96	2.08	2.08	2.33	2.53	
	TFI1310																	15.8	18.2	22.1
	TFI1900																	15.3	17.5	21.3
	TFI2500																	2.38	2.63	2.83
	TFI3300																		25.4	29.2
	TFI6000																		24.7	28.4
	TFI8500																		2.80	2.99
	TFI12000																			

Example (Coupling Size 1310):

90	100	110	115	125	140	155	165	175	185	195
25.4	29.2	33.1	33.5	33.2	38.4	41.0	48.9	54.7	63.0	79.3
24.7	28.4	32.1	31.4	30.8	33.1	36.4	47.1	50.8	58.8	74.3
2.80	2.99	3.29	3.45	3.35	3.35	3.35	3.80	3.80	3.80	4.19

Transmits less than Peak Starting Torque Rating of the Coupling. Therefore the actual Transmissible Torque must be compared against the Application Peak Torque.

Transmits more than Peak Starting Torque Rating of the Coupling.

Pump Spacer Coupling TFI Series w/ Torsi-Lock - Torsiflex-i

API610/ISO13709 | Double Flex Spacer

Example Interpolation Calculation

To interpolate Torsi-Lock table data for a TF 0260 with a size 115 Torsi-Lock for a bore of 3.625":

Y	Z	3.346	dw MIN (Min. Bore)	Target Weight $w = w1 + \frac{Z}{Y} (X)$
		3.625	B (Target Bore)	
		3.740	dw MAX (Max. Bore)	
X	W	21.3	w1 (Wt. @ dw MIN)	Where: Z = B - dw MIN Y = dw MAX - dw MIN X = w2 - w1
		19.3	w2 (Wt. @ dw MAX)	
		19.3	(Target Wt.)	

Note that the same method can be used to determine actual Torsiloc transmissible torque ratings for bores that are in between the min and max.

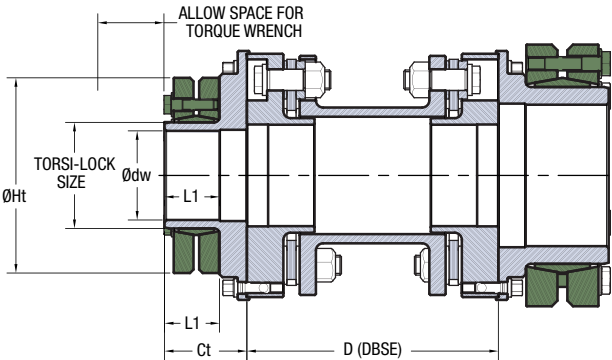

110	115	125	140	155	165	175	185	195	200	220	240	260	280	300	320	340	350	360	380	390
3.150	3.346	3.740	4.134	4.921	5.512	5.709	6.102	6.496	6.890	7.283	7.874	8.465	9.252	9.843	10.630	11.417	12.008	12.205	12.598	12.992
80	85	95	105	120	140	145	155	165	175	185	200	215	235	250	270	290	305	310	320	330
3.346	3.740	4.134	4.921	5.512	5.709	6.102	6.496	6.890	7.283	7.874	8.465	9.252	9.843	10.630	11.417	12.008	12.205	12.598	12.992	13.780
85	95	105	125	140	145	155	165	175	185	200	215	235	250	270	290	305	310	320	330	350
63.7	81.4	93.4	124	99	283	345	412	558	655	733	1,000	1,204	1,513	1,885	2,301	2,655	3,292	3,186	3,850	4,470
95.6	133	122	181	257	341	407	478	642	748	929	1,190	1,478	1,841	2,257	2,664	2,983	3,540	3,673	4,133	5,098
2.24	2.40	2.31	2.31	2.31	2.76	2.76	2.76	3.15	3.15	3.71	3.71	4.03	4.50	4.50	4.58	4.58	5.31	5.31	5.87	5.87
7.28	7.28	7.28	8.66	9.65	10.24	10.83	11.61	12.40	12.99	13.58	14.57	15.55	16.73	18.11	19.49	21.06	21.46	21.85	23.03	23.43
13.0	13.2	13.2	17.6	22.1	30.9	35.3	44.1	59.5	66.2	77.2	97.0	106	132	165	185	221	265	276	331	344
20.7	21.3																			
19.9	19.3																			
3.01	3.16																			
22.4	23.0	22.8	28.2																	
21.6	21.0	20.7	23.3																	
3.01	3.16	3.07	3.07																	
26.0	26.5	26.2	31.6	34.4																
25.1	24.4	24.0	26.5	30.0																
3.13	3.28	3.19	3.19	3.19																
33.1	33.5	33.2	38.4	41.0	48.9	54.7	63.0	79.3												
32.1	31.4	30.8	33.1	36.4	47.1	50.8	58.8	74.3												
3.29	3.45	3.35	3.35	3.35	3.80	3.80	3.80	4.19												
41.5	42.0	41.6	46.8	49.2	57.1	62.8	71.0	87.2	91.0	109										
40.6	39.8	39.2	41.3	44.5	55.1	58.8	66.7	82.2	85.7	98.9										
3.37	3.52	3.43	3.43	3.43	3.88	3.88	3.88	4.27	4.27	4.84										
	50.0	49.4	54.5	56.7	64.3	69.9	78.0	94.0	97.5	115	137									
	47.7	46.9	48.8	51.7	62.3	65.7	7.5	88.8	92.0	105	126									
	3.70	3.60	3.60	3.60	4.05	4.05	4.05	4.44	4.44	5.01	5.01									
			62.0	64.2	71.7	77.4	85.4	101	105	122	144	157								
			56.2	59.2	69.7	73.2	80.9	96.2	99.5	112	133	141								
			3.60	3.60	4.05	4.05	4.05	4.44	4.44	5.01	5.01	5.32								
				87.6	95.0	101	108	124	128	148	166	179	207	244	262					
				82.5	93.0	96.3	104	119	122	135	155	162	192	222	239					
				3.75	4.19	4.19	4.19	4.59	4.59	5.15	5.15	5.47	5.94	5.94	6.02					
					132	140	155	158	175	196	208	236	271	289	321	364	381			
					127	135	150	152	164	184	191	220	249	265	302	357	366			
					4.43	4.43	4.82	4.82	5.39	5.39	5.70	6.17	6.17	6.25	6.25	6.99	6.99			
								191	193	210	231	243	270	305	322	353	396	413	487	499
								185	187	199	219	225	254	282	297	334	389	397	470	463
								4.98	4.98	5.55	5.55	5.86	6.33	6.33	6.41	6.41	7.15	7.15	7.70	7.70

79.3 — Combined weight of the hub and Torsi-Lock device at the MIN shaft diameter.

74.4 — Combined weight of the hub and Torsi-Lock device at the MAX shaft diameter.

4.19 — Ct: Overall hub length thru bore (not including pilot lip)

Floating Shaft Couplings

PRODUCT DESCRIPTION

- Used for coupling spans that are greater than max catalog length for fully machined spacer designs
- Designed for moderate speed applications
- Construction includes:
 - Two fully machined steel hubs
 - One dynamically balanced welded or composite tube spacer
 - Standard hardware and stainless steel disc packs
- Form-Flex® A-Series designs use non-unitized disc packs
- Form-Flex® G-Series designs use unitized disc packs
- Spacers are configured for any custom length up to D-max shown per operating speed
- Can be bored for any shaft configuration (see page F5-40 for hub design options)

TYPICAL APPLICATIONS

- Fans
- Turbo Compressors
- Vertical Pumping
- Cooling Tower
- Printing Press
- Paper Machines

SPECIAL APPLICATIONS

- Mine Ventilation
- Dynamometers
- Test Stands
- Dredging Equipment
- Lift Tables

DESIGN VARIATIONS

- A5/G5 - Welded Steel Tube
- A6/G6 - Welded Steel Tube - Vertical
- A7/G7 - Welded Steel Tube - Semi-Floating Spacer
- A5C/G5C - Composite Tube
- A6C/G6C - Composite Tube - Vertical
- A7C/G7C - Composite Tube - Semi-Floating

Large tube designs are available for speeds greater than catalog limits or for torsional tuning. Consult TB Wood's engineering for more info.



Floating Shaft Spacer Coupling A5 Series - Form-Flex®

Double Flex Floating Shaft

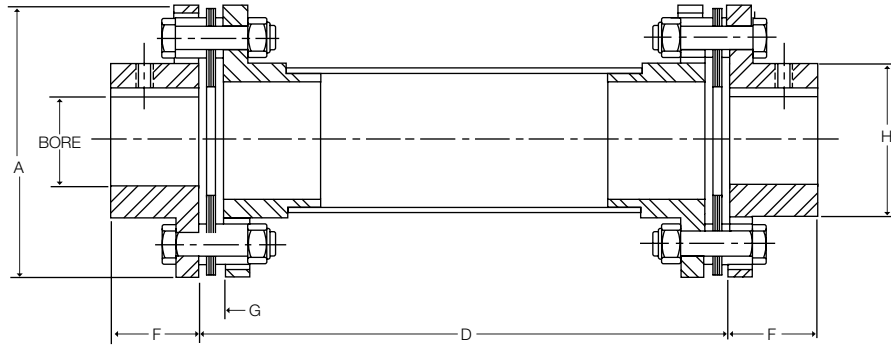

Size	Max Bore				Dimensions (in)					Max D (in) for RPM Shown					
	AJ		AZ		A	D Min	F	G	H	1800	1500	1200	900	750	600
	(in)	(mm)	(in)	(mm)											
5	0.875	22	1.19	30	2.65	4.94	1.00	0.24	1.30	51	56	62	71	78	87
10	1.250	33	1.63	43	3.19	5.00	1.00	0.27	1.80	62	69	76	88	96	107
15	1.375	36	1.75	48	3.65	6.63	1.13	0.32	2.00	64	71	79	91	99	111
20	1.688	46	2.13	58	4.08	6.63	1.32	0.34	2.40	73	81	90	103	113	126
25	2.000	53	2.56	68	4.95	9.88	1.62	0.45	2.80	79	87	97	112	122	137
30	2.380	63	2.88	79	5.63	9.94	1.88	0.47	3.30	85	94	102	120	132	147
35	2.938	80	3.75	101	6.63	13.06	2.25	0.55	4.15	97	107	119	137	150	168

Dimensions are shown for standard AJ hubs unless otherwise specified.

Size	HP/100 RPM	Rated Torque (lb-in)	Peak O/L Torque (lb-in)	Weight (lbs) (1)		WR ² (lb-in ²) (1)		Misalignment Capacity	
				at D min	Add Per Inch of D	at D min	Add Per Inch of D	Axial (+/-in)	Angular (Degrees/Disc Pack)
5	0.48	300	600	2.71	0.11	1.93	0.03	0.030	1°
10	1.27	800	1,600	4.14	0.10	4.83	0.07	0.040	
15	2.5	1,575	3,150	6.14	0.10	9.36	0.07	0.042	
20	3.49	2,200	4,400	8.69	0.21	15.36	0.22	0.055	
25	6.03	3,800	7,600	14.98	0.20	42.07	0.29	0.060	
30	11	6,930	13,860	22.78	0.29	84.97	0.56	0.065	
35	18	11,340	22,680	32.02	0.40	170.84	1.32	0.085	

1) Weight and WR² values shown are for AJ hubs at max inch bore and spacer length at D Min

STANDARD MATERIALS (CLASS A)

HUBS - CARBON STEEL

SPACER - CARBON STEEL

HARDWARE - ALLOY STEEL

DISC PACK - STAINLESS STEEL

ORDERING

A5 Series couplings are sold as complete assemblies. Please specify hub types and bore sizes, DBSE (D) dimension, speed for dynamic balancing, and material class. A coupling will be configured to meet your specifications.

MATERIAL / FINISH OPTIONS

CLASS A - Steel hubs and spacer, alloy steel hardware, 300 series stainless steel disc pack

CLASS B - Zinc plated steel hubs, and spacer, alloy steel hardware, 300 series stainless steel disc pack

CLASS C - Zinc plated steel hubs, and spacer, stainless steel hardware, 300 series stainless steel disc pack

CLASS E - 300 series stainless steel hubs and spacer, stainless steel hardware, 300 series stainless steel disc pack

(Only available for sizes 15 thru 35)

Floating Shaft Spacer Coupling G5 Series - Form-Flex®

Double Flex Floating Shaft



Size	Torque Rating			Weight (1) (lb)		WR ² (1) (lb-in ²)		Misalignment Capacity	
	HP / 100 (RPM)	Max Continuous (lb-in)	Peak Overload (lb-in)	at D Min	Add Per Inch	at D Min	Add Per Inch	Axial (+/- in)	Angular (Degrees/ Disc Pack)
311	17	11,000	22,000	22.67	0.39	86.75	1.28	0.028	0.5°
321	33	20,500	41,000	32.24	0.44	148.2	1.88	0.029	
332	51	32,000	64,000	47.06	0.47	271.2	2.24	0.030	
346	73	46,000	92,000	77.73	1.11	568.7	6.95	0.050	
380	127	80,000	160,000	102.5	1.17	944.6	8.04	0.080	
412	190	120,000	240,000	151.5	2.04	1,972.6	19.15	0.080	0.33°
419	301	190,000	380,000	248.2	2.21	4,137	24.24	0.100	
424	476	300,000	600,000	358.3	3.04	9,456	63.33	0.100	
444	690	435,000	870,000	502.2	3.38	15,621	86.52	0.110	
456	1015	640,000	1,280,000	633.6	4.89	24,595	147.92	0.120	
483	1317	830,000	1,660,000	880.0	5.11	37,972	169.02	0.130	
511	1904	1,200,000	2,400,000	1132	5.11	64,246	169.02	0.140	
520	3173	2,000,000	4,000,000	CONSULT TB WOOD'S				0.180	
525	3967	2,500,000	5,000,000					0.200	
530	4760	3,000,000	6,000,000					0.200	
540	6347	4,000,000	8,000,000					0.240	

1) Weight and WR² values shown are for standard at max inch bore and spacer length at D Min

STANDARD MATERIALS

HUBS - CARBON STEEL

SPACER - CARBON STEEL

HARDWARE - ALLOY STEEL

DISC PACK - STAINLESS STEEL

MATERIAL OPTIONS

DISC PACK - ALLOY STEEL (for cost reduction, only available on sizes 412 to 540)

ZINC ELECTRO PLATING

ZINC PHOSPHATE COATING

ALLOY STEEL HUBS

DESIGN VARIATIONS

- G5 - Welded Steel Tube
- G6 - Welded Steel Tube—Vertical
- G7 - Welded Steel Tube—Semi-Floating Spacer
- G5C - Composite Tube
- G6C - Composite Tube—Vertical
- G7C - Composite Tube— Semi-Floating

Floating Shaft Spacer Coupling G5 Series - Form-Flex®

Double Flex Floating Shaft

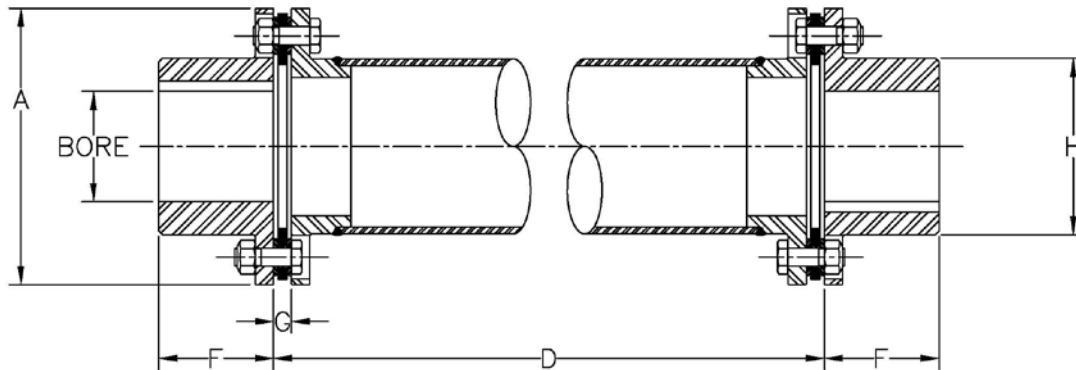

Size	Max Bore						Common Coupling Dimensions (in)								Max D (in) for RPM Shown					
	Standard Hub			Oversized/Large Hub			A	D Min	F	G	H		Tube		1800	1500	1200	900	750	600
	Square Key (in)	Rect. Key (in)	Rect. Key (mm)	Square Key (in)	Rect. Key (in)	Rect. Key (mm)					Std Hub	O/S Hub	OD	ID						
311	2.813	3.063	78	3.125	3.313	86	5.88	12.750	2.50	0.40	3.91	4.30	3.63	3.39	94	103	116	134	146	164
321	3.000	3.250	83	3.250	3.438	90	6.38	13.063	3.00	0.55	4.25	4.57	4.00	3.76	101	110	124	143	156	175
332	3.188	3.313	87	3.438	3.688	95	7.20	13.188	3.50	0.61	4.50	4.95	4.25	4.01	104	114	127	147	161	180
346	3.750	4.000	107	4.250	4.500	117	8.20	19.188	3.75	0.62	5.42	5.95	5.25	4.75	111	122	136	157	172	192
380	3.750	4.000	105	4.250	4.500	118	9.42	19.750	4.13	0.89	5.65	6.30	5.50	5.00	114	125	140	161	177	197
412	4.500	4.500	120	4.750	5.125	135	11.00	19.438	4.25	0.75	6.51	7.20	6.50	5.75	123	135	151	174	191	213
419	4.500	4.875	130	5.500	5.625	150	12.50	19.938	5.00	0.98	7.32	8.07	7.00	6.25	128	140	157	181	198	222
424	6.625	6.880	190				15.00	19.938	6.25	0.98	9.57		9.50	8.75	150	164	184	212	233	260
444	7.000	7.375	200				16.38	20.125	7.00	1.09	10.52		10.50	9.75	158	173	194	224	245	274
456	8.000	8.000	220				18.00	20.625	7.25	1.32	11.63		11.50	10.50	165	181	202	233	256	286
483	8.250	8.875	234				19.44	20.750	8.50	1.39	12.56		12.00	11.00	168	184	206	238	261	292
511	10.000	10.125	280				22.00	21.063	9.00	1.56	14.50		12.00	11.00	168	184	206	238	261	292
520	10.375	11.000	297				24.88	21.750	11.88	1.89	16.10									
525	11.000	12.000	322				26.75	21.875	12.00	1.95	17.35									
530	11.500	12.750	338				28.00	22.250	12.75	2.14	18.35									
540	15.750	17.000	448				33.50	24.125	15.00	2.58	22.63									

ORDERING

G5 SERIES COUPLINGS ARE SOLD AS COMPLETE ASSEMBLIES
 PLEASE SPECIFY BORE SIZES, DISC PACK MATERIAL AND DBSE.
 A COUPLING WILL BE CONFIGURED TO MEET YOUR SPECIFICATIONS.

Floating Shaft Spacer Coupling A5C/B5C Composite Series - Form-Flex®

Double Flex Spacer

Form-Flex® flexible couplings may be mated to composite tubes for use as long floating shaft couplings. All types and most sizes of Form-Flex® couplings can be mated to composite tubes. Common combinations are shown below.

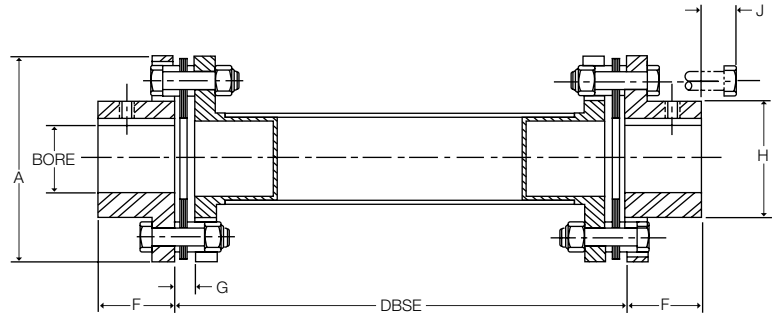

Type	Rated Torque*** lb-in	HP/ 100 RPM	Coupling Product No.	Maximum DBSE (in)			Maximum Bore			
				Max	@1800 RPM	@1500 RPM	Std Hub		AZ Hub	
							Square Key (in)	Reduced Key (in[mm])	Square Key (in)	Reduced Key (in[mm])
A5C20	2,200	3.49	A5C20_2G	84	72	79	1.625	1.75 [45]	2.125	2.188 [57]
			A5C20_2R	84	84*	84*				
A5C25	3,800	6.03	A5C25_2G	83	71	78	2.00	2.063 [52]	2.500	2.750 [68]
			A5C25_2R	83	83*	83*				
A5C30	6,930	11	A5C30_3R	130	107	117	2.375	2.438 [61]	2.875	3.063 [78]
			A5C30_3B	130	122	130*				
A5C35	11,340	18	A5C35_4R	147	123	135	2.875	3.125 [80]	3.750	3.75 [100]
			A5C35_4B	147	140	147*				
			A5C35_6R	152	149	152*				
			A5C35_6B	181	170	181*				
			A5C35_6BL	196	-	187				
			A5C35_8R	196	184	196*				
			A5C35_8B	196	196	196*				
			A5C35_8BL	236	-	215				
A5C40	18,270	29	A5C40_4R	147	123	135	3.250	3.375 [88]	4.000	4.375 [113]
			A5C40_4B	147	140	147*				
B5C58	34,000	54	B5C58_6R	181	149	151	4.000	4.250 [110]	5.000	5.500 [143]
			B5C58_6B	181	170	181*				
			B5C58_6BL	196	-	187				
			B5C58_6X	196	174	190				
			B5C58_8R	197	184	197*				
			B5C58_8B	197	196	197*				
			B5C58_8BL	237	-	215				
			B5C58_10B**	237	213	237*				
			B5C58_12B**	237	237*	237*				

Type	Coupling Product No.	Dimensions (in) (1)					Misalignment Capacity	
		A	F	G	H	J	Axial (+/- in)	Angular (Degrees/ Disc Pack)
A5C20	A5C20_2G	4.08	1.32	0.34	2.40	2.30	0.055	1°
	A5C20_2R					2.30		
A5C25	A5C25_2G	4.95	1.62	0.45	2.80	2.30	0.060	1°
	A5C25_2R					2.30		
A5C30	A5C30_3R	5.63	1.88	0.47	3.30	3.25	0.065	1°
	A5C30_3B					3.25		
A5C35	A5C35_4R	6.63	2.25	0.55	4.15	4.25	0.085	1°
	A5C35_4B					4.25		
	A5C35_6R					6.30		
	A5C35_6B					6.30		
	A5C35_6BL					6.30		
	A5C35_8R					8.31		
	A5C35_8B					8.31		
	A5C35_8BL					8.31		
A5C40	A5C40_4R	7.63	2.50	0.60	4.65	4.25	0.100	1°
	A5C40_4B					4.25		
B5C58	B5C58_6R	8.98	2.75	0.56	5.81	6.30	0.118	0.7°
	B5C58_6B					6.30		
	B5C58_6BL					6.30		
	B5C58_6X					6.30		
	B5C58_6XL					6.30		
	B5C58_8R					8.31		
	B5C58_8B					8.31		
	B5C58_8BL					8.31		
	B5C58_10B**					10.31		
	B5C58_12B**					12.31		

* Length is restricted by available mandrels for winding composite tubes.

Consult factory for longer lengths.

** Tube diameter is larger than coupling "A" diameter. Consult factory for coupling drawing.

*** Peak Overload Torque Rating is 1.5 times Rated Torque

1) Dimensions are shown with standard hubs

Floating Shaft Spacer Coupling A5C/B5C Composite Series - Form-Flex®

QUICK SELECTION GUIDE FOR COOLING TOWER APPLICATIONS

1800 RPM				Coupling Model	1500 RPM			
DBSE		Max Power			Max Power		Max DBSE	
mm	in	Kw	HP		Kw	HP	mm	in
1828	72	23	31	A5C20_2G	20	26	2004	79
1802	71	40	54	A5C25_2G	34	45	1980	78
2133*	84*	23	31	A5C20_2R	20	26	2133*	84*
2108*	83*	40	54	A5C25_2R	34	45	2108*	83*
2723	107	74	99	A5C30_3R	62	82	2985	117
3101	122	74	99	A5C30_3B	62	82	3302*	130*
3130	123	121	161	A5C35_4R	100	134	3431	135
3129	123	194	260	A5C40_4R	162	217	3431	135
3564	140	121	161	A5C35_4B	100	134	3734*	147*
3563	140	194	260	A5C40_4B	162	217	3734*	147*
3799	149	121	161	A5C35_6R	100	134	3862*	152*
3807	149	362	485	B5C58_6R	302	404	3854	151
4327	170	121	161	A5C35_6B	100	134	4597*	181*
4337	170	362	485	B5C58_6B	302	404	4592*	181*
-	-	121	161	A5C35_6BL	100	134	4746	187
-	-	362	485	B5C58_6BL	302	404	4754	187
4423	174	362	485	B5C58_6X	302	404	4849	190
4671	184	121	161	A5C35_8R	100	134	4975*	196*
4682	184	362	485	B5C58_8R	302	404	5004*	197*
4975*	196*	121	161	A5C35_8B	100	134	4975	196
4974	196	362	485	B5C58_8B	302	404	5004*	197*
-	-	121	161	A5C35_8BL	100	134	5459	215
-	-	362	485	B5C58_8BL	302	404	5456	215
5414	213	362	485	B5C58_10B	302	404	6020*	237*
6020*	237*	362	485	B5C58_12B	302	404	6020*	237*

All sections use a 2.0 service factor

ORDER CODE

A5C35_6B

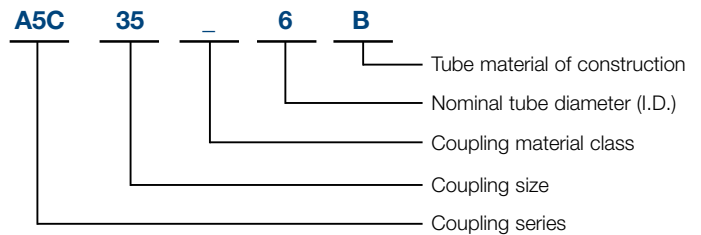

COMPOSITE TUBE CONSTRUCTION

Model Code	Tube Material of Construction
G	GLASS
R	CARBON/GLASS HYBRID
B	STANDARD CARBON
X,Z	HIGH MODULUS CARBON

Material Class	Material Used		
	Hub	Hardware	Spacer Flanges
A	STEEL	STEEL	COMPOSITE OR STEEL
B	STEEL, ZINC PLATE	STEEL	COMPOSITE OR ZINC PLATED STEEL
C		304SS	
E	304SS	304SS	COMPOSITE OR 304SS

Metal spacer flanges used if composite is not available.

* Length is restricted by available mandrels for winding composite tubes. Consult factory for longer lengths.

** Tube diameter is larger than coupling "A" diameter. Consult factory for coupling drawing.

Close Coupled Couplings

PRODUCT DESCRIPTION

- Used for close shaft spacing where traditional spacer couplings cannot be used
- Designed for moderate speed applications
- Construction includes:
 - Two fully machined steel hubs
 - One flat bar or machined block style spacer
 - Standard hardware and stainless steel disc packs
- Form-Flex® designs use non-unitized disc packs

Spacers are configured for minimal shaft separation. Shorter shaft separation is possible by allowing the shafts to extend through the disc packs into the center of the coupling. The shaft diameter must be less than the flex pack I.D. listed in the dimensional table.



TYPICAL APPLICATIONS

- Machine Tools
- Ball Screws
- Pumps
- Printing Machines

SPECIAL APPLICATIONS

- Elastomeric Coupling Replacement
- Cranes
- Gear Coupling Replacement

Close Coupled Coupling AX Series - Form-Flex®

General Use - Double Flex Short Spacer

The AX series close coupling is made up of two hubs, a steel spacer block, two stainless steel disc packs and AX hardware. A special bolting arrangement supports the spacer between the flex discs. The AX is an economical design that is well suited to many general purpose applications. The AX accommodates close shaft separations when it is installed with the shafts extending through the flex discs into the center of the coupling. The shaft diameter must be less than the disc pack I.D. listed in the dimensional table.

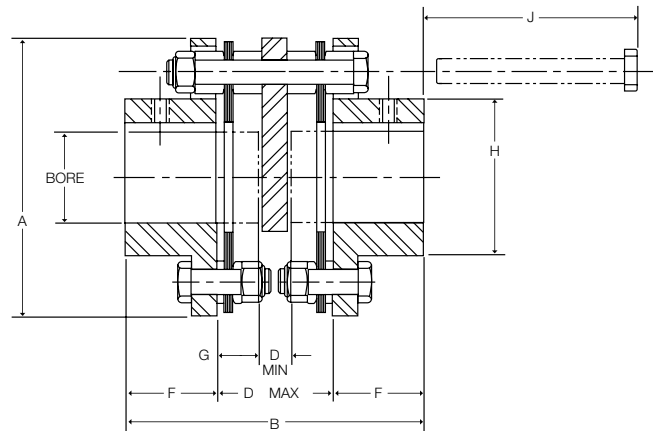

Size	Max Bore				Dimensions (in)*								
	AJ		AZ		A	B	DBSE		F	G	H	J	DISC PACK I.D.**
	(in)	(mm)	(in)	(mm)			D** Min	D Max					
5	0.875	22	1.19	30	2.65	3.34	0.38	1.34	1.00	0.48	1.30	1.68	1.00
10	1.250	33	1.63	43	3.19	3.40	0.44	1.40	1.00	0.48	1.30	1.79	1.17
15	1.375	36	1.75	48	3.65	3.80	0.63	1.54	1.13	0.44	2.00	1.85	1.28
20	1.688	46	2.13	58	4.08	4.22	0.63	1.58	1.32	0.48	2.40	1.66	1.65
25	2.000	53	2.56	68	4.95	5.36	0.75	2.12	1.62	0.69	2.80	2.39	1.78
30	2.380	63	2.88	79	5.63	6.30	1.00	2.54	1.88	0.77	3.30	3.18	2.01
35	2.938	80	3.75	101	6.63	7.17	1.13	2.67	2.25	0.77	4.15	2.81	2.71

* Dimension shown are for AJ hubs unless otherwise specified.

** Shaft O.D. must be less than Disc Pack I.D. in order to extend shafts into the coupling to meet D Min dimensions.

Size	HP/100 RPM	Rated Torque (lb-in)	Peak O/L Torque (lb-in)	Max RPM	Weight (lbs) (1)	WR ² (lb-in ²) (1)	Misalignment Capacity	
							Axial (+/-in)	Angular (Degrees/Disc Pack)
5	0.48	300	450	8,500	1.63	1.26	0.030	1°
10	1.27	800	1,200	7,500	2.48	2.9	0.040	
15	2.5	1,575	2,363	6,700	3.84	5.8	0.042	
20	3.49	2,200	3,300	6,200	5.1	9.16	0.055	
25	6.03	3,800	5,700	5,500	9.13	26.1	0.060	
30	11	6,930	10,395	5,000	13.8	51.7	0.065	
35	18	11,340	17,010	4,400	21.1	108	0.085	

1) Weight and WR² values shown are for AJ hubs at max inch bore.

STANDARD MATERIALS (CLASS A)

HUBS - CARBON STEEL

SPACER - CARBON STEEL

HARDWARE - ALLOY STEEL

DISC PACKS - STAINLESS STEEL

ORDERING

AX SERIES COUPLINGS ARE SOLD AS COMPONENTS
COUPLINGS CONSIST OF:

2 - HUBS - Example (AJ25A x 1-3/4")

1 - SPACER SUB-ASSEMBLY - Example (AX25SAA)

STANDARD MATERIALS (CLASS A)

CLASS A - Mild steel hubs and spacer, alloy steel hardware, 300 series stainless steel disc packs

CLASS B - Zinc plated steel hubs, and spacer, alloy steel hardware, 300 series stainless steel disc packs

Close Coupled Coupling AA Series - Form-Flex®

General Use with Shorter Bolt Removal - Double Flex

The AA series close coupling is made up of two hubs, a cast iron block type spacer and two sets of standard hardware. Stainless steel disc packs are standard. The AA accommodates close shaft separations when it is installed with the shafts extending through the disc pack into the center of the coupling. The shaft diameter must be less than the disc pack I.D. listed in the dimensional table. This coupling is recommended when the bolt removal length (J) makes the AX coupling impractical.

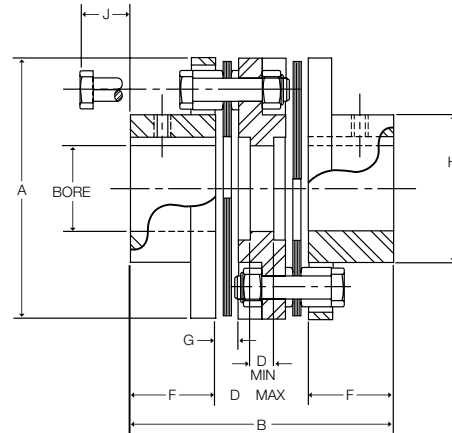

Size	Max Bore				Dimensions (in)*									Disc Pack I.D.**
	AJ		AZ		A	B	DBSE		F	G	H	J		
	(in)	(mm)	(in)	(mm)			D** Min	D Max						
5	0.875	22	1.19	30	2.65	3.23	0.25	1.23	1.00	0.24	1.30	0.54	1.00	
10	1.250	33	1.63	43	3.19	3.73	0.25	1.73	1.00	0.27	1.80	0.56	1.17	
15	1.375	36	1.75	48	3.65	3.82	0.31	1.56	1.13	0.32	2.00	0.88	1.28	
20	1.688	46	2.13	58	4.08	4.38	0.41	1.74	1.32	0.34	2.40	0.79	1.65	
25	2.000	53	2.56	68	4.95	5.26	0.41	2.02	1.62	0.45	2.80	1.00	1.78	
30	2.380	63	2.88	79	5.63	6.24	0.56	2.48	1.88	0.47	3.30	1.14	2.01	
35	2.938	80	3.75	101	6.63	6.91	0.66	2.41	2.25	0.55	4.15	0.97	2.71	

* Dimension shown are for AJ hubs unless otherwise specified.

** Shaft O.D. must be less than Disc Pack I.D. in order to extend shafts into the coupling to meet D Min dimensions.

Size	HP/100 RPM	Rated Torque (lb-in)	Peak O/L Torque (lb-in)	Max RPM	Weight (lbs) (1)	WR ² (lb-in ²) (1)	Misalignment Capacity	
							Axial (+/-in)	Angular (Degrees/Disc Pack)
5	0.48	300	450	3,600	1.76	1.4	0.030	1°
10	1.27	800	1,200	3,500	2.77	3.35	0.040	
15	2.5	1,575	2,363	3,450	4.24	6.66	0.042	
20	3.49	2,200	3,300	3,350	5.48	10.2	0.055	
25	6.03	3,800	5,700	3,200	9.81	29.4	0.060	
30	11	6,930	10,395	3,000	15.0	59.0	0.065	
35	18	11,340	17,010	2,800	22.4	121	0.085	

1) Weight and WR² values shown are for AJ hubs at max inch bore.

STANDARD MATERIALS (CLASS A)

HUBS - CARBON STEEL

SPACER - CARBON STEEL

HARDWARE - ALLOY STEEL

DISC PACK - STAINLESS STEEL

ORDERING

AA SERIES COUPLINGS ARE SOLD AS COMPONENTS

COUPLINGS CONSIST OF:

2 - HUBS - Example (AJ25A x 1-3/4")

1 - SPACER SUB-ASSEMBLY - Example (AA25SAA)

MATERIAL / FINISH OPTIONS

CLASS A - Steel hubs and spacer, alloy steel hardware, 300 series stainless steel disc pack

CLASS B - Zinc plated steel hubs, and spacer, alloy steel hardware, 300 series stainless steel disc pack

CLASS C - Zinc plated steel hubs, and spacer, stainless steel hardware, 300 series stainless steel disc pack

Close Coupled Coupling AY Series - Form-Flex®

Positioning Applications - Double Flex Short Spacer

The AY series is specifically designed for positioning applications where a servo or stepper drive is C flange mounted and connects to a ball screw. The AY accommodates the small amounts of angular and parallel misalignment with an absolute minimum size package, zero backlash and high torsional stiffness. The AY is made up of two hubs, a steel spacer block, two stainless steel disc packs and AY hardware. The coupling must be installed as an assembled unit. The spacer is not service removable.

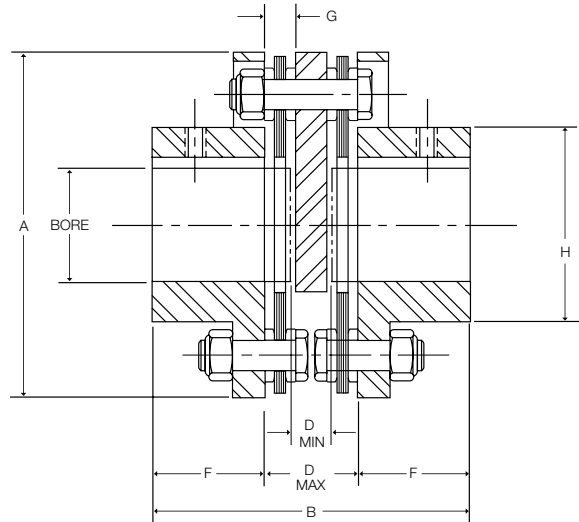

Size	Max Bore				Dimensions (in)*							
	AJ		AZ		A	B	DBSE		F	G	H	Disc Pack I.D.**
	(in)	(mm)	(in)	(mm)			D** Min	D Max				
5	0.875	22	1.19	30	2.65	2.85	0.49	0.85	1.00	0.24	1.30	1.00
10	1.250	33	1.63	43	3.19	2.91	0.50	0.91	1.00	0.27	1.80	1.17
15	1.375	36	1.75	48	3.65	3.33	0.56	1.07	1.13	0.32	2.00	1.28
20	1.688	46	2.13	58	4.08	3.76	0.56	1.12	1.32	0.34	2.40	1.65
25	2.000	53	2.56	68	4.95	4.77	0.87	1.53	1.62	0.45	2.80	1.78

* Dimension shown are for AJ hubs unless otherwise specified.

** Shaft O.D. must be less than Disc Pack I.D. in order to extend shafts into the coupling to meet D Min dimensions.

Size	HP/100 RPM	Rated Torque (lb-in)	Peak O/L Torque (lb-in)	Max RPM	Weight (lbs) (1)	WR ² (lb-in ²) (1)	Misalignment Capacity	
							Axial (+/-in)	Angular (Degrees/Disc Pack)
5	0.48	300	600	8,500	1.64	1.24	0.030	1°
10	1.27	800	1,600	7,500	2.68	3.08	0.040	
15	2.5	1,575	3,150	6,700	4.23	6.41	0.042	
20	3.49	2,200	4,400	6,200	5.49	9.92	0.055	
25	6.03	3,800	7,600	5,500	9.78	27.6	0.060	

1) Weight and WR2 values shown are for AJ hubs at max inch bore.

STANDARD MATERIALS (CLASS A)

HUBS - CARBON STEEL

SPACER - CARBON STEEL

HARDWARE - ALLOY STEEL

DISC PACK - STAINLESS STEEL

ORDERING

AY SERIES COUPLINGS ARE SOLD AS COMPONENTS
COUPLINGS CONSIST OF:

2 - HUBS - Example (AJ25A x 1-3/4")

1 - SPACER SUB-ASSEMBLY - Example (AY25SAA)

MATERIAL / FINISH OPTIONS

CLASS A - Mild steel hubs and spacer, alloy steel hardware, 300 series stainless steel disc pack

CLASS B - Zinc plated steel hubs, and spacer, alloy steel hardware, 300 series stainless steel disc pack

Single Flex Couplings

PRODUCT DESCRIPTION

- Single Flex Couplings accommodate angular and axial misalignment only
- Construction includes:
 - Two fully machined steel hubs
 - Standard hardware and stainless steel disc packs
- Form-Flex® A-Series designs use non-unitized disc packs
- Form-Flex® G-Series designs use unitized disc packs
- Not intended for elastomeric coupling replacement
- Hubs can be single plane balanced for higher speed applications
- Can be bored for any shaft configuration (see page F5-40 for hub design options)

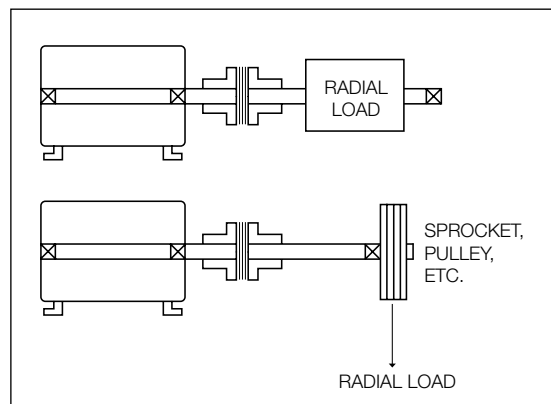

TYPICAL APPLICATIONS

- Should only be used in three bearing system
- Used in pairs for floating shaft arrangement
- Can be used in pairs to support other components
 - Clutches
 - Brakes
 - Sheaves
- Mixers
- Single coupling can be used to support a component when a self-aligning bearing is used

SPECIAL APPLICATIONS

- Torque Monitoring Equipment

Single Flex Coupling AR Series - Form-Flex®

Single Flex Short Spacing

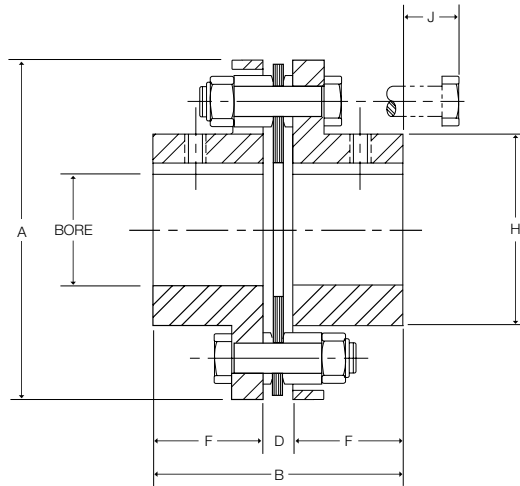

Size	Max Bore				Dimensions (in)*					
	AJ		AZ		A	B	D	F	H	J
	(in)	(mm)	(in)	(mm)			DBSE			
5	0.875	22	1.19	30	2.65	2.24	0.24	1.00	1.30	0.54
10	1.250	33	1.63	43	3.19	2.27	0.27	1.00	1.80	0.59
15	1.375	36	1.75	48	3.65	2.58	0.32	1.13	2.00	0.88
20	1.688	46	2.13	58	4.08	2.98	0.34	1.32	2.40	0.79
25	2.000	53	2.56	68	4.95	3.69	0.45	1.62	2.80	1.00
30	2.380	63	2.88	79	5.63	4.23	0.47	1.88	3.30	1.14
35	2.938	80	3.75	101	6.63	5.05	0.55	2.25	4.15	0.97

* Dimension shown are for AJ hubs unless otherwise specified.

Size	HP/100 RPM	Rated Torque (lb-in)	Peak O/L Torque (lb-in)	AGMA 7 Max RPM	Max Radial Load (lbs)	Weight (1) (lbs)	WR ² (1) (lb-in ²)	Misalignment Capacity	
								Axial (+/-in)	Angular (Degrees/Disc Pack)
5	0.48	300	600	8,500	34	1.24	0.96	0.015	1°
10	1.27	800	1,600	7,500	56	1.96	2.35	0.020	
15	2.5	1,575	3,150	6,700	125	2.98	4.62	0.021	
20	3.49	2,200	4,400	6,200	183	4.07	7.48	0.027	
25	6.03	3,800	7,600	5,500	275	7.01	20.4	0.030	
30	11	6,930	13,860	5,000	400	10.8	41.5	0.032	
35	18	11,340	22,680	4,400	600	17.2	88.3	0.042	

1) Weight and WR² values shown are for AJ hubs at max inch bore.

STANDARD MATERIALS (CLASS A)

HUBS - CARBON STEEL

SPACER - CARBON STEEL

HARDWARE - ALLOY STEEL

DISC PACKS - STAINLESS STEEL

ORDERING

AR SERIES COUPLINGS ARE SOLD AS COMPONENTS

COUPLINGS CONSIST OF:

2 - HUBS - Example (AJ25A x 1-3/4")

1 - REPAIR KIT - Example (A25RKA)

MATERIAL / FINISH OPTIONS

CLASS A - Steel hubs, alloy steel hardware, 300 series stainless steel disc packs

CLASS B - Zinc plated steel hubs and spacer, alloy steel hardware, 300 series stainless steel disc pack

CLASS C - Zinc plated steel hubs, stainless steel hardware, 300 series stainless steel disc packs

CLASS E - 300 series stainless steel hubs, stainless steel hardware, 300 series stainless steel disc packs

Single Flex Coupling GR Series - Form-Flex®

Single Flex Short Spacing



Size	Torque Rating			Max Speed (RPM)		Max Radial Load (lbs)	Weight (lbs) (1)	WR ² (lb-in ²) (1)	Misalignment Capacity	
	HP / 100 (RPM)	Max Continuous (lb-in)	Peak Overload (lb-in)	AGMA 8	ABS. Max				Axial (+/- in)	Angular (Degrees/ Disc Pack)
311	17	11,000	22,000	8,000	13,000	360	11.0	41.5	0.014	0.5°
321	33	20,500	41,000	7,400	12,000	800	17.8	77.6	0.0145	
332	51	32,000	64,000	6,600	11,500	1,300	26.2	143	0.015	
346	73	46,000	92,000	6,100	9,000	1,300	38.1	271	0.025	
380	127	80,000	160,000	5,500	7,000	2,400	53.1	469	0.040	
412	190	120,000	240,000	5,200	6,000	2,400	72.5	935	0.040	0.33°
419	301	190,000	380,000	4,600	5,000	4,200	129.3	2092	0.050	
424	476	300,000	600,000	4,200	5,000	4,200	195.8	4936	0.050	
444	690	435,000	870,000	3,800	4,000	5,300	291.5	8422	0.055	
456	1015	640,000	1,280,000	3,600	3,500	6,700	364.0	13226	0.060	
483	1317	830,000	1,660,000	3,300	3,500	8,200	512.0	20843	0.065	
511	1904	1,200,000	2,400,000	3,100	3,000	9,800	677.2	37076	0.070	
520	3173	2,000,000	4,000,000	2,800	2,500	15,700	1208	71849	0.090	
525	3967	2,500,000	5,000,000	2,700	2,500	17,900	1473	113939	0.100	
530	4760	3,000,000	6,000,000	2,500	2,500	21,000	1752	148626	0.100	
540	6347	4,000,000	8,000,000	2,300	2,000	23,000	2662	346946	0.120	

1) Weight and WR² values shown are for standard hubs at max inch bore.

STANDARD MATERIALS

HUBS - CARBON STEEL

SPACER - CARBON STEEL

HARDWARE - ALLOY STEEL

DISC PACKS - STAINLESS STEEL

MATERIAL / FINISH OPTIONS

DISC PACKS - ALLOY STEEL (For cost reduction, available for sizes 412 to 540)

ZINC ELECTRO PLATING

ZINC PHOSPHATE COATING

ALLOY STEEL HUBS

Single Flex Coupling GR Series - Form-Flex®

Single Flex Short Spacing

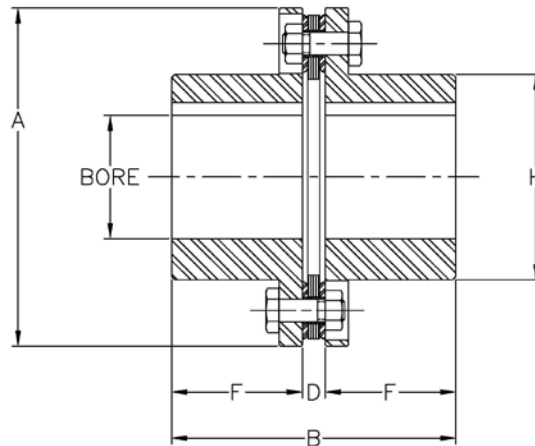

Size	Max Bore						Dimensions (in)					
	Standard Hub			Oversized/Large Hub			A	B	D DBSE	F	H	
	Square Key (in)	Rect. Key (in)	Rect. Key (mm)	Square Key (in)	Rect. Key (in)	Rect. Key (mm)					Std Hub	O/S Hub
311	2.813	3.063	78	3.125	3.313	86	5.88	5.40	0.40	2.50	3.91	4.30
321	3.000	3.250	83	3.250	3.438	90	6.38	6.55	0.55	3.00	4.25	4.57
332	3.188	3.313	87	3.438	3.688	95	7.20	6.62	0.62	3.50	4.50	4.95
346	3.750	4.000	107	4.250	4.500	117	8.20	6.62	0.62	3.75	5.42	5.95
380	3.750	4.000	105	4.250	4.500	118	9.42	9.14	0.89	4.13	5.65	6.30
412	4.500	4.500	120	4.750	5.125	135	11.00	9.25	0.75	4.25	6.51	7.20
419	4.500	4.875	130	5.500	5.625	150	12.50	10.98	0.98	5.00	7.32	8.07
424	6.625	6.880	190				15.00	13.48	0.98	6.25	9.57	
444	7.000	7.375	200				16.38	15.09	1.09	7.00	10.52	
456	8.000	8.000	220				18.00	15.82	1.32	7.25	11.63	
483	8.250	8.875	234				19.44	18.39	1.39	8.50	12.56	
511	10.000	10.125	280				22.00	19.56	1.56	9.00	14.50	
520	10.375	11.000	297				24.88	25.64	1.89	11.88	16.10	
525	11.000	12.000	322				26.75	25.95	1.95	12.00	17.35	
530	11.500	12.750	338				28.00	27.64	2.14	12.75	18.35	
540	15.750	17.000	448				33.50	32.58	2.58	15.00	22.63	

ORDERING

GR SERIES COUPLINGS ARE SOLD AS COMPONENTS

COUPLINGS CONSIST OF:

2 - HUBS - Example (GH346 x 2-1/2")

1 - REPAIR KIT - Example (G346SF)

Heavy Duty Spacer Coupling

PRODUCT FEATURES

- Designed for low to medium speed equipment
- Standard designs for applications requiring shaft-to-shaft or shaft to flywheel connection.
- Construction
 - Fully machined steel hubs are standard
 - Ductile Iron or Class 30 Grey Iron spacer/spyder
 - Ductile Iron or Class 30 Grey Iron flywheel adapter
 - Alloy steel hardware and High Carbon steel disc packs
- Form-Flex® HSH/FSH Series designs use non-unitized disc packs
- Form-Flex® GCH/GCF Series designs use unitized disc packs
- Industry standard length spacer
- Can be bored for any shaft configuration (see page F5-41 for hub design options)
- Special flange mountings are also available to bolt custom flanges on any equipment.



TYPICAL APPLICATIONS

- Reciprocating Compressors
- Metal Shredders
- Rock Crushers
- Engine Driven Equipment
- Mixer

SPECIAL APPLICATIONS

- Can be modified for API671 with exceptions
- Added inertia to torsionally tune system
- Altered stiffness for torsional tuning
- Custom designs for demanding applications

SPECIAL APPLICATIONS

Example: Coupling shown was specially designed for a high torque, low speed (10000HP @ 290RPM) application to torsionally tune the system. This is a 10 bolt disc pack design and the coupling is rated for 10,000,000 lb-in with an OD measuring 44.50". Flange mounted on both ends with a custom adapter hub on the motor's keyless shaft.



Heavy Duty Spacer Coupling GCH Series - Form-Flex®

Double Flex Spacer

Size	Spacer	Max Bore		Dimensions (in)					
		(in)	(mm)	A	B	D	F	G	H
340	31	3.75	100	8.38	9.89	4.14	2.88	0.57	5.44
	35				10.46	4.71			
412	42	4.50	120	11.00	14.07	5.57	4.25	0.75	6.51
	45				14.57	6.07			
	50				15.69	7.19			
424	55	6.88	190	15.00	19.95	7.45	6.25	0.98	9.57
	60				20.95	8.45			
456	70	8.00	220	18.00	24.13	9.63	7.25	1.32	11.63
	75				25.20	10.70			
511	80	10.00	280	22.00	29.39	11.39	9.00	1.56	14.50
	85				30.39	12.39			
	92				31.89	13.89			

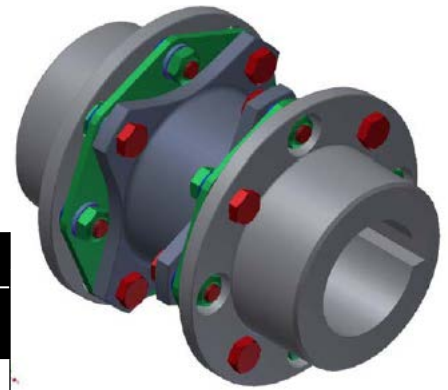
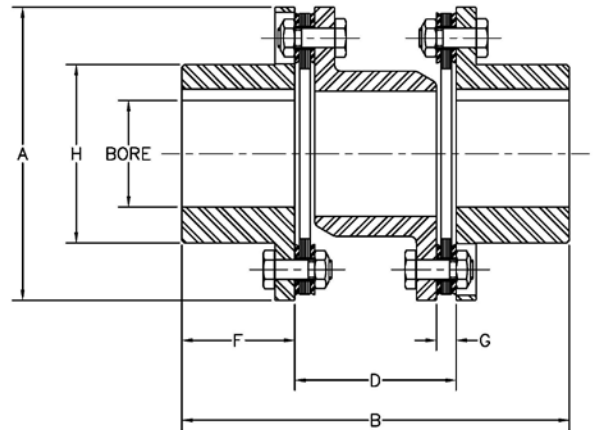

Size	Spacer	Rated Torque		Peak Overload (lb-in)	Max RPM	Weight (1) (lbs)	WR ² (1) (lb-in ²)	Misalignment Capacity	
		HP/100 RPM	(lb-in)					Axial +/- in	Angular (Degrees/Disc Pack)
340	31	64	40,000	60,000	3,400	43	344	0.06	0.33°
	35					44	349		
412	42	190	120,000	180,000	2,500	106	1,371	0.08	
	45					108	1,385		
	50					112	1,416		
424	55	380	240,000	360,000	1,800	278	7,141	0.10	
	60					284	7,259		
456	70	889	560,000	840,000	1,500	527	19,517	0.12	
	75					538	19,793		
511	80	1,746	1,100,000	1,650,000	1,200	964	54,373	0.14	
	85					980	55,013		
	92					1,108	64,414		

Note: Couplings available for torque capacity up to 1129815 Nm. Contact Altra Couplings engineering with application details for coupling selection.

STANDARD MATERIALS

HUBS - CARBON STEEL

SPACER - DUCTILE IRON

HARDWARE - ALLOY STEEL

DISC PACKS - HIGH CARBON STEEL

MATERIAL / FINISH OPTIONS

DISC PACKS - STAINLESS STEEL

ZINC PHOSPHATE COATING

ALLOY STEEL HUBS

STEEL SPACER

NOTES:

- 1) Weight and WR² are calculated with hubs at maximum inch bore size.
- 2) Consult factory for torsional stiffness and alternating torque limits.

ORDERING

GCH SERIES COUPLINGS ARE SOLD AS COMPLETE ASSEMBLIES

- 1) Specify coupling size and spacer option

Example: GCH424-60 5" x 6-1/4"

- 2) Specify hub bore size and tolerance, keyway size or keyless, special hub length, etc. Please specify for each hub.

Heavy Duty Spacer Coupling GCF Series - Form-Flex®

Double Flex Spacer

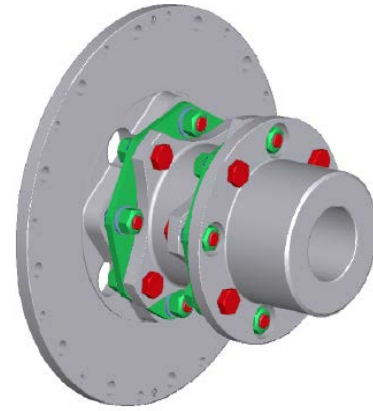
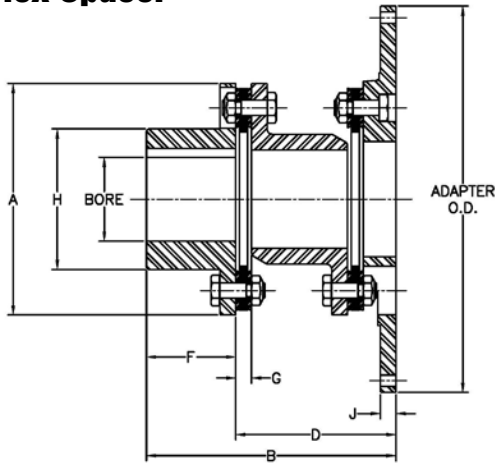

Size	Spacer	Max Bore		Dimensions (in)							Adapter O.D. / Standard Bolt Pattern											
		(in)	(mm)	A	B	D	F	G	H	J	Size	12.375	13.875	18.375	20.375	22.500	26.500	28.875				
340	31	3.75	100	8.38	8.19	5.31	2.88	0.57	5.44	0.5	12	14	18	20	22	26	28					
	8.76				5.88	Order												SAE	SAE	Order	SAE	
412	42	4.50	120	11.00	11.39	7.14	4.25	0.75	6.51	0.57	18	20	22	26	28	SAE/HD	SAE/HD					
	45				11.89	7.64												SAE	Order	SAE	SAE/HD	SAE/HD
	50				13.01	8.76												SAE/HD	Order	SAE/HD	SAE/HD	SAE/HD
424	55	6.88	190	15.00	16.14	9.89	6.25	0.98	9.57	1.00	20	22	26	28	SAE/HD	SAE/HD						
	60				17.14	10.89											SAE/HD	Order	SAE/HD	SAE/HD	SAE/HD	
456	70	8.00	220	18.00	19.69	12.44	7.25	1.32	11.63	1.13	22	26	28	SAE/HD	SAE/HD							
	75				20.76	13.51										SAE/HD	SAE/HD	SAE/HD				
511	80	10.00	280	22.00	23.76	14.76	9.00	1.56	14.5	1.38	26	28	SAE/HD	SAE/HD								
	85				24.76	15.76									SAE/HD	SAE/HD						
	92				26.26	17.26									SAE/HD	SAE/HD						
SAE Bolting																						
BC	11.625	13.125	17.25	19.25	21.375	25.25	27.25															
Hole Qty	8	8	8	8	6	12	12															
Hole Dia	0.41	0.41	0.53	0.53	0.65	0.65	0.78															
HD Bolting																						
BC	11.5	12.5	16.75	18.5	20.5	24.5	26.875															
Hole Qty	8	8	8	8	8	12	12															
Hole Dia	0.53	0.65	0.78	0.91	1.03	1.03	1.03															
Speed Limit by Adapter O.D. (2b)																						
RPM	3,400	3,400	2,900	2,600	2,400	2,000	1,800															

Size	Spacer	Rated Torque		Peak Overload	Max RPM (2a)	Weight (1)	WR ² (1)	Misalignment Capacity			
		HP/100 RPM	(lb-in)					(lb-in)	Axial (+/- in)	Angular (Degrees/Disc Pack)	
340	31	64	40,000	60,000	3,400	46	567	0.06	0.33°		
	35									47	572
412	42	190	120,000	180,000	2,500	127	3,267	0.08	0.33°		
	45									129	3,281
	50									132	3,312
424	55	380	240,000	360,000	1,800	261	8,346	0.10	0.33°		
	60									268	8,464
456	70	889	560,000	840,000	1,500	491	22,549	0.12	0.33°		
	75									502	22,825
511	80	1,746	1,100,000	1,650,000	1,200	870	58,863	0.14	0.33°		
	85									885	59,503
	92									1014	68,905

- 1) Weight and WR2 calculated with hub at maximum inch bore size and minimum available adapter size.
- 2) a) Max RPM shown for smallest available adapter size, do not exceed this speed for any given coupling size.
b) Verify that adapter speed limit is adequate for application speed, do not exceed coupling MAX RPM (See note 2a).
- 3) Flywheel mounting hardware is not supplied with coupling.
- 4) Consult factory for torsional stiffness and alternating torque limits.

ORDERING

- 1) Specify coupling size and spacer option
Example: GCF424-60
- 2) Specify adapter size code. Specify bolting pattern for items noted as drilled per order.
Example: GCF424-60-26 or GCF424-60-22HD
- 3) Specify hub bore size and tolerance, keyway size or keyless, special hub length, etc.

STANDARD MATERIALS

HUB - CARBON STEEL
 SPACER - DUCTILE IRON
 FLYWHEEL ADAPTER - DUCTILE IRON
 HARDWARE - ALLOY STEEL
 DISC PACKS - HIGH CARBON STEEL

Heavy Duty Spacer Coupling HSH Series - Form-Flex®

Double Flex Spacer

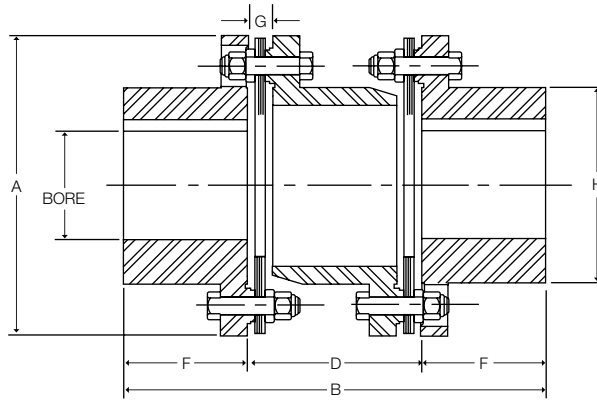

STANDARD MATERIALS

HUBS - CARBON STEEL
 SPACER - GREY OR DUCTILE IRON
 HARDWARE - ALLOY STEEL
 DISC PACKS - HIGH CARBON STEEL

MATERIAL / FINISH OPTIONS

DISC PACKS - STAINLESS STEEL
 ZINC PHOSPHATE COATING
 ALLOY STEEL HUBS
 CAST IRON HUBS
 (Sizes 31-45)

Size	Dimensions (in)									
	Max Bore				A (2)	B	D DBSE	F	G	H
	Iron		Steel							
(in)	(mm)	(in)	(mm)							
22	-	-	2.75	79	5.88	8.02	3.02	2.50	0.43	3.87
26	-	-	3.25	92	6.88	9.25	3.50	2.88	0.55	4.50
31	3.12	82	4.13	113	8.12	10.87	4.12	3.37	0.62	5.50
35	3.62	97	4.50	125	9.12	12.06	4.57	3.75	0.66	6.12
37	3.75	100	4.63	130	10.06	13.12	5.14	4.00	0.81	6.50
42	4.25	114	5.00	142	11.00	13.93	5.43	4.25	0.81	7.00
45	4.50	120	5.50	150	11.87	14.75	5.75	4.50	0.87	7.43
50	-	-	6.13	170	12.90	16.81	6.81	5.00	1.06	8.37
55	-	-	6.88	193	15.00	18.68	7.68	5.50	1.25	9.50
60	-	-	7.50	212	16.00	20.93	8.43	6.25	1.34	10.50
70	-	-	8.50	233	18.50	23.62	9.56	7.00	1.50	11.75
75	-	-	9.00	261	20.00	25.00	10.50	7.25	1.53	13.00
80	-	-	9.12	275	22.00	26.87	11.37	7.75	1.56	13.75
85	-	-	10.38	290	23.75	28.62	12.12	8.25	1.62	14.50
92	-	-	11.00	320	25.75	31.00	13.01	9.00	1.75	15.87
92HT	-	-	10.50	307	25.75	31.00	13.01	9.00	1.75	15.87

Size	HP/ 100 RPM	Rated Torque (lb-in)	Peak O/L Torque (lb-in)	Max RPM	Weight (lbs) (1)	WR ² (lb-in ²) (1)	Misalignment Capacity	
							Axial (+/- in)	Angular (Degrees/ Discpack)
22	15.1	9,500	14,250	3,800	19.7	75.6	0.036	0.33°
26	25.4	16,000	24,000	3,300	28.8	152	0.044	
31	38.1	24,000	36,000	2,800	51.4	390	0.052	
35	69.8	44,000	66,000	2,600	76.7	738	0.056	
37	95.2	60,000	90,000	2,500	92.4	1,090	0.062	
42	116	73,000	109,500	2,400	125	1,710	0.067	
45	157	99,000	148,500	2,250	154	2,510	0.072	
50	203	128,000	192,000	2,000	218	4,570	0.082	
55	300	189,000	283,500	1,800	288	7,400	0.092	
60	414	261,000	391,500	1,600	403	13,100	0.102	
70	659	415,000	622,500	1,400	624	25,800	0.115	
75	846	533,000	799,500	1,300	788	37,900	0.125	
80	1,087	685,000	1,027,500	1,200	1,030	58,700	0.136	
85	1,316	829,000	1,243,500	1,100	1,230	79,000	0.140	
92	1,651	1,040,000	1,560,000	1,000	1,630	129,000	0.156	
92HT	2,221	1,400,000	2,100,000	1,000	1,680	137,000	0.156	

- 1) Weight and WR² are calculated with steel hubs at maximum inch bore size.
- 2) Consult factory for torsional stiffness and alternating torque limits.

ORDERING

HSH SERIES COUPLINGS ARE SOLD AS COMPLETE ASSEMBLIES (Components and repair kits are available for repairs)

- 1) Specify coupling
- 2) Specify hub bore size and tolerance, keyway size or specify for each hub.
- 3) Specify disc pack material

Heavy Duty Spacer Coupling FSH Series - Form-Flex®

Double Flex Spacer

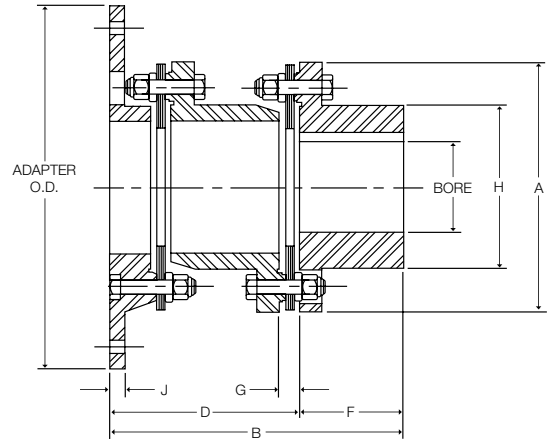

Adapter O.D. / Standard Bolt Pattern

	12.375	13.875	18.375	20.375	22.500	26.500	28.875
	12	14	18	20	22	26	28
SAE Bolting							
BC	11.625	13.125	17.25	19.25	21.375	25.25	27.25
Hole Qty	8	8	8	8	6	12	12
Hole Dia	0.41	0.41	0.53	0.53	0.65	0.65	0.78
HD Bolting							
BC	11.50	12.50	16.75	18.50	20.50	24.50	26.875
Hole Qty	8	8	8	8	8	12	12
Hole Dia	0.53	0.65	0.78	0.91	1.03	1.03	1.03

STANDARD MATERIALS

HUBS - CARBON STEEL
 SPACER - DUCTILE IRON OR CAST IRON
 FLYWHEEL ADAPTER - DUCTILE IRON OR CAST IRON
 HARDWARE - ALLOY STEEL
 DISC PACKS - HIGH CARBON STEEL

Size	Max Bore				Dimensions (in)							Available Adapter Sizes							
	Iron		Steel		A	B	D DBSE	F	G	H	J	X = Stock Size 0 = MTO							
	(in)	(mm)	(in)	(mm)								10	12	14	18	20	22	26	28
31	3.12	82	4.13	113	8.12	8.68	5.31	3.37	0.62	5.50	0.50	0	0	X	X	0	0		
35	3.62	97	4.50	125	9.12	9.62	5.87	3.75	0.66	6.12	0.50	0	0	X	X	0	0		
37	3.75	100	4.63	130	10.06	10.62	6.62	4.00	0.81	6.50	0.56			0	0	0	0		
42	4.25	114	5.00	142	11.00	11.37	7.12	4.25	0.81	7.00	0.63			0	X	0	X	X	0
45	4.50	120	5.50	150	11.87	12.00	7.50	4.50	0.87	7.43	0.69			0	X	0	X	X	0
50	-	-	6.13	170	12.90	13.75	8.75	5.00	1.06	8.37	0.75				X	0	X	X	X
55	-	-	6.88	193	15.00	15.31	9.81	5.50	1.25	9.50	0.88				X	0	X	X	X
60	-	-	7.50	212	16.00	17.12	10.87	6.25	1.34	10.50	1.00				X	0	X	X	X
70	-	-	8.50	233	18.50	19.43	12.43	7.00	1.50	11.75	1.00					X	X	X	X
75	-	-	9.00	261	20.00	20.75	13.50	7.25	1.53	13.00	1.13					0	0	0	X
80	-	-	9.12	275	22.00	22.50	14.75	7.75	1.56	13.75	1.25							0	X
85	-	-	10.38	290	23.75	24.00	15.75	8.25	1.62	14.50	1.25								X
92	-	-	11.00	320	25.75	26.25	17.27	9.00	1.75	15.87	1.38								X
92HT	-	-	10.50	307	25.75	26.25	17.26	9.00	1.75	15.87	1.38								X

Size	HP/ 100 RPM	Rated Torque (lb-in)	Peak O/L Torque (lb-in)	Max RPM (2)	Weight (lbs) (1)	WR ² (lb-in ²) (1)	Misalignment Capacity	
							Axial +/- in	Angular (Degrees/ Disc Pack)
31	38.1	24,000	36,000	2,800	41	399	0.052	0.33°
35	69.8	44,000	66,000	2,600	59	643	0.056	
37	95.2	60,000	90,000	2,500	82	1,280	0.062	
42	116	73,000	109,500	2,400	107	1,770	0.067	
45	157	99,000	148,500	2,250	127	2,370	0.072	
50	203	128,000	192,000	2,000	189	5,320	0.082	
55	300	189,000	283,500	1,800	241	7,590	0.092	
60	414	261,000	391,500	1,600	325	11,800	0.102	
70	659	415,000	622,500	1,400	523	25,000	0.115	
75	846	533,000	799,500	1,300	675	35,000	0.125	
80	1,087	685,000	1,027,500	1,200	905	58,400	0.136	
85	1,316	829,000	1,243,500	1,100	1060	79,400	0.140	
92	1,651	1,040,000	1,560,000	1,000	1,400	120,000	0.156	
92HT	2,221	1,400,000	2,100,000	1,000	1,450	129,000	0.156	

- 1) Weight and WR² calculated with steel hubs at maximum inch bore size and minimum available adapter size.
- 2) a) Max RPM shown for smallest available adapter size, do not exceed this speed for any given coupling size.
 b) Verify that adapter speed limit is adequate for application speed, do not exceed coupling MAX RPM (See note 2a).
- 3) Flywheel mounting hardware is not supplied with coupling.
- 4) Consult factory for torsional stiffness and alternating torque limits.

ORDERING

FSH SERIES COUPLINGS ARE SOLD AS COMPLETE ASSEMBLIES (Components and repair kits are for repairs)

- 1) Specify coupling size and adapter size
- 2) Specify hub bore size and tolerance, keyway keyless, special hub length, etc.
- 3) Specify disc pack material

Coupling Repair Parts and Kits

Notes:

- 1) Single Repair Kits include 1 disc pack and all bolts, nuts and washers for use with 1 disc pack
- 2) Single hardware Kits include all bolts, nuts and washers for use with 1 disc pack
- 3) Double Repair Kits include 2 disc packs and all hardware for one coupling
- 4) Double hardware kits include all bolt, nuts and washers for one coupling

Form-Flex® (A Series)

Kit Type	Repair				Hardware				Disc Pack	Rough Bore Hub							
SGL/DBL	Single								Double	Double	AJ (Std)			AZ (O/S)			
Used On	AA, AP, AR, A5, A6, A7								AX	AY	All	All	All	All	All	All	All
Mat'l Class	A,B	C,E	A,B	C,E	A,B	A,B	A,B	A,B	A,B	All	A	B,C	E	A	B,C	E	
5	A05RKA	***	A05HKA	***	AX05RKA	AX05HKA	AY05RKA	AY05HKA	A005-4101	AJ05RBA	AJ05RBB	***	AZ05RBA	AZ05RBB	***		
10	A10RKA	***	A10HKA	***	AX10RKA	AX10HKA	AY10RKA	AY10HKA	A010-4101	AJ10RBA	AJ10RBB	***	AZ10RBA	AZ10RBB	***		
15	A15RKA	A15RKE	A15HKA	A15HKE	AX15RKA	AX15HKA	AY15RKA	AY15HKA	A015-4101	AJ15RBA	AJ15RBB	AJ15RBE	AZ15RBA	AZ15RBB	AZ15RBE		
20	A20RKA	A20RKE	A20HKA	A20HKE	AX20RKA	AX20HKA	AY20RKA	AY20HKA	A020-4101	AJ20RBA	AJ20RBB	AJ20RBE	AZ20RBA	AZ20RBB	AZ20RBE		
25	A25RKA	A25RKE	A25HKA	A25HKE	AX25RKA	AX25HKA	AY25RKA	AY25HKA	A025-4101	AJ25RBA	AJ25RBB	AJ25RBE	AZ25RBA	AZ25RBB	AZ25RBE		
30	A30RKA	A30RKE	A30HKA	A30HKE	AX30RKA	AX30HKA	***	***	A030-4101	AJ30RBA	AJ30RBB	AJ30RBE	AZ30RBA	AZ30RBB	AZ30RBE		
35	A35RKA	A35RKE	A35HKA	A35HKE	AX35RKA	AX35HKA	***	***	A035-4101	AJ35RBA	AJ35RBB	AJ35RBE	AZ35RBA	AZ35RBB	AZ35RBE		

Form-Flex® (A5C/B5C Series)

Kit Type	Repair				Hardware				Disc Pack
SGL/DBL	Single								Double
Used On	A5C, B5C								All
Mat'l Class	A,B	C,E	A,B	C,E	A,B	C,E	A,B	C,E	All
15	A5C15RKA	A5C15RKE	A5C15HKA	A5C15HKE	A5C15RKA-DF	A5C15RKE-DF	A5C15HKA-DF	A5C15HKE-DF	A015-4101
20	A5C20RKA	A5C20RKE	A5C20HKA	A5C20HKE	A5C20RKA-DF	A5C20RKE-DF	A5C20HKA-DF	A5C20HKE-DF	A020-4101
25	A5C25RKA	A5C25RKE	A5C25HKA	A5C25HKE	A5C25RKA-DF	A5C25RKE-DF	A5C25HKA-DF	A5C25HKE-DF	A025-4101
30	A5C30RKA	A5C30RKE	A5C30HKA	A5C30HKE	A5C30RKA-DF	A5C30RKE-DF	A5C30HKA-DF	A5C30HKE-DF	A030-4101
35	A5C35RKA	A5C35RKE	A5C35HKA	A5C35HKE	A5C35RKA-DF	A5C35RKE-DF	A5C35HKA-DF	A5C35HKE-DF	A035-4101
58	B5C58RKA	B5C58RKE	B5C58HKA	B5C58HKE	B5C58RKA-DF	B5C58RKE-DF	B5C58HKA-DF	B5C58HKE-DF	B058-4101

Torsiflex-i (TF Series)

Kit Type	Repair Kit (4)	Hardware Kit (1)	Disc Pack (2)	TF Hub Attachment Screw Kit (3)	TFI Hub Attachment Screw Kit (3)	Rough Bore Hub	
Cplg Size			300 Series S.S			Std	Override
0017	TF0017EK	TF0017HK	TF0017-5-SS	TF0017HAS	TFI0017HAS	TFI0027AH	TFI0017LAH
0027	TF0027EK	TF0027HK	TF0027-5-SS	TF0027HAS	TFI0027HAS	TFI0027AH	TFI0027LAH
0038	TF0038EK	TF0038HK	TF0038-5-SS	TF0038HAS	TFI0038HAS	TFI0038AH	TFI0038LAH
0140	TF0140EK	TF0140HK	TF0140-5-SS	TF0140HAS	TFI0140HAS	TFI0140AH	-
0260	TF0260EK	TF0260HK	TF0260-5-SS	TF0260HAS	TFI0260HAS	TFI0260AH	-
0400	TF0400EK	TF0400HK	TF0400-5-SS	TF0400HAS	TFI0400HAS	TFI0400AH	-
0750	TF0750EK	TF0750HK	TF0750-5-SS	TF0750HAS	TFI0750HAS	TFI0750AH	-
1310	TF1310EK	TF1310HK	TF1310-5-SS	TF1310HAS	TFI1310HAS	TFI1310AH	-
1900	TF1900EK	TF1900HK	TF1900-5-SS	TF1900HAS	TFI1900HAS	TFI1900AH	-
2500	TF2500EK	TF2500HK	TF2500-5-SS	TF2500HAS	TFI2500HAS	TFI2500AH	-
3300	TF3300EK	TF3300HK	TF3300-5-SS	TF3300HAS	TFI3300HAS	TFI3300AH	-
6000	TF6000EK	TF6000HK	TF6000-5-SS	TF6000HAS	TFI6000HAS	TFI6000AH	-
8500	TF8500EK	TF8500HK	TF8500-5-SS	TF8500HAS	TFI8500HAS	TFI8500AH	-
12000	TF12000EK	TF12000HK	TF12000-5-SS	TF12000HAS	TFI12000HAS	TFI12000AH	-

- 1) Contains bolts, nuts and washers for 1 disc pack, 2 required for a complete coupling
- 2) Includes 1 complete disc pack, 2 required for a complete coupling
- 3) Contains all fasteners for 1 hub, 2 required for a complete coupling
- 4) Repair Kits include 1 disc pack and all disc pack bolts, nuts and washers for one end of a coupling, 2 kits required for a complete coupling.

Coupling Repair Parts and Kits (Cont.)

Form-Flex® (G Series)

Kit Type	Repair Kits				Hardware Kit	Disc Pack		Rough Bore Hub	
Used On	Double		Single		Single (1)	SS	CS	Std	Oversize
Mat'l Class	Disc Pack SS	Disc Pack CS	Disc Pack SS	Disc Pack CS					
311	G311-DF-SS	-	G311-SF-SS	-	G311-HK	G311-5-SS	-	G311-3ST	G311-3LST
321	G321-DF-SS	-	G321-SF-SS	-	G321-HK	G321-5-SS	-	G321-3ST	G321-3LST
332	G332-DF-SS	-	G332-SF-SS	-	G332-HK	G332-5-SS	-	G332-3ST	G332-3LST
346	G346-DF-SS	-	G346-SF-SS	-	G346-HK	G346-5-SS	-	G346-3ST	G346-3LST
380	G380-DF-SS	-	G380-SF-SS	-	G380-HK	G380-5-SS	-	G380-3ST	G380-3LST
412	G412-DF-SS	G412-DF	G412-SF-SS	G412-SF	G412-HK	G412-5-SS	G412-5	G412-3ST	G412-3LST
419	G419-DF-SS	G419-DF	G419-SF-SS	G419-SF	G419-HK	G419-5-SS	G419-5	G419-3ST	G419-3LST
424	G424-DF-SS	G424-DF	G424-SF-SS	G424-SF	G424-HK	G424-5-SS	G424-5	G424-3ST	-
444	G444-DF-SS	G444-DF	G444-SF-SS	G444-SF	G444-HK	G444-5-SS	G444-5	G444-3ST	-
456	G456-DF-SS	G456-DF	G456-SF-SS	G456-SF	G456-HK	G456-5-SS	G456-5	G456-3ST	-
483	G483-DF-SS	G483-DF	G483-SF-SS	G483-SF	G483-HK	G483-5-SS	G483-5	G483-3ST	-
511	G511-DF-SS	G511-DF	G511-SF-SS	G511-SF	G511-HK	G511-5-SS	G511-5	G511-3ST	-
520	G520-DF-SS	G520-DF	G520-SF-SS	G520-SF	G520-HK	G520-5-SS	G520-5	G520-3ST	-
525	G525-DF-SS	G525-DF	G525-SF-SS	G525-SF	G525-HK	G525-5-SS	G525-5	G525-3ST	-
530	G530-DF-SS	G530-DF	G530-SF-SS	G530-SF	G530-HK	G530-5-SS	G530-5	G530-3ST	-
540	G540-DF-SS	G540-DF	G540-SF-SS	G540-SF	G540-HK	G540-5-SS	G540-5	G540-3ST	-

Form-Flex® (HSH/FSH Series)

Kit Type	Repair Kits				Hardware Kit	Disc Pack		Rough Bore Hub	
Cplg Size	Double		Single (1)		Single (2)	SS	CS	STL	Cast Iron
	Disc Pack SS	Disc Pack CS	Disc Pack SS	Disc Pack CS					
22	D22-DF-SS	D22-DF	D22-SF-SS	D22-SF	D22-BNW	D22-5-SS	D22-5	D22-3ST	-
26	D26-DF-SS	D26-DF	D26-SF-SS	D26-SF	D26-BNW	D26-5-SS	D26-5	D26-3ST	-
31	D31-DF-SS	D31-DF	D31-SF-SS	D31-SF	D31-BNW	D31-5-SS	D31-5	D31-3ST	D31-3
35	D35-DF-SS	D35-DF	D35-SF-SS	D35-SF	D35-BNW	D35-5-SS	D35-5	D35-3ST	D35-3
37	D37-DF-SS	D37-DF	D37-SF-SS	D37-SF	D37-BNW	D37-5-SS	D37-5	D37-3ST	D37-3
42	D42-DF-SS	D42-DF	D42-SF-SS	D42-SF	D42-BNW	D42-5-SS	D42-5	D42-3ST	D42-3
45	D45-DF-SS	D45-DF	D45-SF-SS	D45-SF	D45-BNW	D45-5-SS	D45-5	D45-3ST	D45-3
50	D50-DF-SS	D50-DF	D50-SF-SS	D50-SF	D50-BNW	D50-5-SS	D50-5	D50-3ST	-
55	D55-DF-SS	D55-DF	D55-SF-SS	D55-SF	D55-BNW	D55-5-SS	D55-5	D55-3ST	-
60	D60-DF-SS	D60-DF	D60-SF-SS	D60-SF	D60-BNW	D60-5-SS	D60-5	D60-3ST	-
70	D70-DF-SS	D70-DF	D70-SF-SS	D70-SF	D70-BNW	D70-5-SS	D70-5	D70-3ST	-
75	D75-DF-SS	D75-DF	D75-SF-SS	D75-SF	D75-BNW	D75-5-SS	D75-5	D75-3ST	-
80	D80-DF-SS	D80-DF	D80-SF-SS	D80-SF	D80-BNW	D80-5-SS	D80-5	D80-3ST	-
85	D85-DF-SS	D85-DF	D85-SF-SS	D85-SF	D85-BNW	D85-5-SS	D85-5	D85-3ST	-
92	D92-DF-SS	D92-DF	D92-SF-SS	D92-SF	D92-BNW	D92-5-SS	D92-5	D92-3ST	-
92HT	D92HT-DF-SS	D92HT-DF	D92HT-SF-SS	D92HT-SF	D92HT-BNW	D92-5-SS	D92-5	D92HT-3ST	-

Form-Flex® (GCH/GCF Series)

Kit Type	Repair Kits				Hardware Kit	Disc Pack		Rough Bore Hub
Cplg Size	Double		Single (1)		Single (2)	SS	CS	STL
	Disc Pack SS	Disc Pack CS	Disc Pack SS	Disc Pack CS				
340	G340-DF-SS	G340-DF	G340-SF-SS	G340-SF	G340-BN	G340-5-SS	G340-5	G340-3ST
412	G412-DF-SS	G412-DF	G412-SF-SS	G412-SF	G412-BN	G412-5-SS	G412-5	G412-3ST
424	G424-DF-SS	G424-DF	G424-SF-SS	G424-SF	G424-BN	G424-5-SS	G424-5	G424-3ST
456	G456-DF-SS	G456-DF	G456-SF-SS	G456-SF	G456-BN	G456-5-SS	G456-5	G456-3ST
511	G511-DF-SS	G511-DF	G511-SF-SS	G511-SF	G511-BN	G511-5-SS	G511-5	G511-3ST

Form-Flex® A-Series Hub Options

TO ORDER A COMPLETE COUPLING, ORDER TWO HUBS OF ANY TYPE AND A COUPLING (SPACER) SUB ASSEMBLY FOR THE REQUIRED COUPLING TYPE. ALL DIMENSIONS SHOWN IN INCHES.

AJ STANDARD HUBS - PROVIDED WITH STRAIGHT BORE AND KEYWAY - SOLID HUBS AVAILABLE FROM STOCK

Size	Max Bore		A	B	F	H	J	Std Set Screw Size
	(in)	(mm)						
05	0.875	22	2.65	0.25	1.00	1.30	0.38	#10-24 UNC
10	1.250	33	3.19	0.30	1.00	1.80	0.38	1/4-20 UNC
15	1.375	36	3.65	0.35	1.13	2.00	0.41	1/4-20 UNC
20	1.688	46	4.08	0.35	1.32	2.40	0.50	1/4-20 UNC
25	2.000	53	4.95	0.45	1.62	2.80	0.63	5/16-18 UNC
30	2.380	63	5.63	0.55	1.88	3.30	0.69	5/16-18 UNC
35	2.938	80	6.63	0.55	2.25	4.15	0.88	1/2-13 UNC

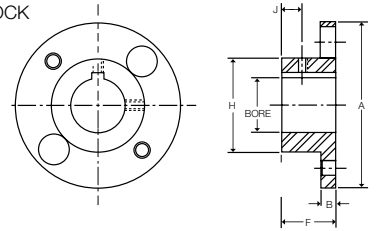

AZ OVERSIZE BORE HUBS - PROVIDED WITH STRAIGHT BORE AND KEYWAY

Size	Max Bore		A	B	F	H	J	Std Set Screw Size
	(in)	(mm)						
05	1.188	30	2.65	0.25	1.00	1.88	0.38	#10-24 UNC
10	1.625	43	3.19	0.30	1.00	2.37	0.38	1/4-20 UNC
15	1.750	48	3.65	0.35	1.13	2.69	0.41	1/4-20 UNC
20	2.125	58	4.08	0.35	1.32	3.13	0.50	1/4-20 UNC
25	2.563	68	4.95	0.45	1.62	3.75	0.63	5/16-18 UNC
30	2.875	79	5.63	0.55	1.88	4.25	0.69	5/16-18 UNC
35	3.750	101	6.63	0.55	2.25	5.25	0.88	1/2-13 UNC

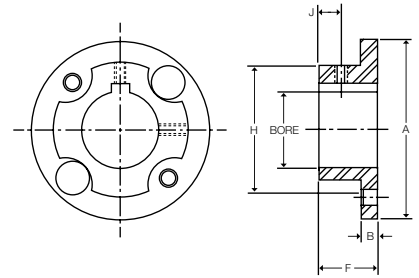

QD BORED HUBS - MATERIAL CLASS A OR B ONLY

Size	Bush Size	Bush TQ. (lb-in)	Max Bore		B	C	F	H	Bolt Size
			(in)	(mm)					
15	JA	1000	1.250	28	1.17	1.00	0.56	2.00	#10-24 UNC
20	JA	1000	1.250	28	1.17	1.00	0.56	2.40	#10-24 UNC
25	SH	3500	1.688	35	1.50	1.25	0.75	2.80	1/4-20 UNC
30	SD	5000	2.000	42	2.06	1.81	1.25	3.30	1/4-20 UNC
35	SK	7000	2.625	55	2.19	1.87	1.25	4.15	5/16-18 UNC
40	SF	11000	2.938	65	2.38	2.06	1.37	4.65	3/8-16 UNC

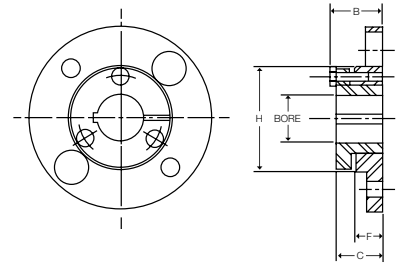

HUBS FOR TAPER LOCK BUSHINGS - AVAILABLE MTO ONLY

Size	Regular Mount					Reverse Mount				
	Bush Size	Bush TQ. (lb-in)	Max Bore		F (in)	Bush Size	Bush TQ. (lb-in)	Max Bore		F (in)
			(in)	(mm)				(in)	(mm)	
15	N/A	-	-	-	-	1108	1300	1.12	25	0.87
20	1108	1300	1.12	25	0.87	1215	3550	1.25	32	1.50
25	1215	3550	1.25	32	1.50	1310	3850	1.37	35	1.00
30	1310	3850	1.37	35	1.00	1615	4300	1.62	42	1.50
35	2012	7150	2.00	48	1.25	2517	11600	2.50	65	1.75
40	2525	11300	2.50	65	2.50	2525	11300	2.50	65	2.50

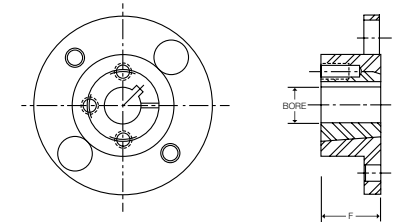

AC/AD CLAMPING HUBS - AC HUBS PROVIDED WITHOUT KEYWAY - AD HUBS PROVIDED WITH KEYWAY - MATERIAL CLASS A OR B ONLY

Size	Max Bore				A	F	G	H	Clamp Screw Size
	AC		AD						
	(in)	(mm)	(in)	(mm)					
5	1.00	25	0.87	20	2.65	1.13	0.50	2.06	1/4-20 UNC
10	1.00	25	0.87	20	3.19	1.18	0.50	2.06	1/4-20 UNC
	1.50	38	1.25	30		1.36	0.69	2.75	5/16-18 UNC
15	1.00	25	0.87	20	3.65	1.27	0.50	2.06	1/4-20 UNC
	1.75	44	1.37	24		1.46	0.69	3.00	5/16-18 UNC
20	1.31	33	1.00	24	4.08	1.32	0.55	2.38	1/4-20 UNC
	2.13	53	1.62	42		1.52	0.75	3.50	3/8-16 UNC
25	2.13	53	1.62	42	4.95	1.62	0.64	3.50	5/16-18 UNC
	2.50	63	1.87	50		1.86	0.88	4.00	3/8-16 UNC

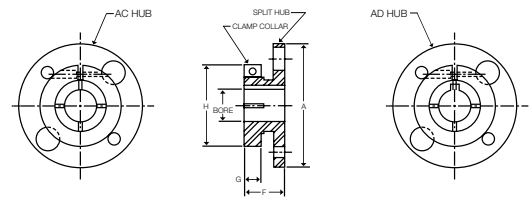

AL LOCK ELEMENT HUBS - THESE HUBS USE RINGFEDER TAPERED LOCKING ELEMENTS - MATERIAL CLASS A OR B ONLY

Size	Hub Type	Bore Size				B	F	G	Screw Size
		Min		Max					
		(in)	(mm)	(in)	(mm)				
5	AJ	0.24	6	0.51	13	1.00	1.32	0.32	#10-32 UNF
	AZ	0.55	14	0.75	19	1.00	1.42	0.42	1/4-28 UNF
10	AJ	0.47	12	0.71	18	1.00	1.42	0.42	1/4-28 UNF
	AZ	0.75	19	1.18	30	1.00	1.42	0.42	1/4-28 UNF
15	AJ	0.47	12	0.87	22	1.13	1.55	0.42	1/4-28 UNF
	AZ	0.94	24	1.38	35	1.13	1.55	0.42	1/4-28 UNF
20	AJ	0.87	22	1.18	30	1.32	1.78	0.42	1/4-28 UNF
	AZ	1.26	32	1.65	42	1.32	1.83	0.51	5/16-24 UNF
25	AJ	0.87	22	1.26	32	1.63	2.05	0.42	1/4-28 UNF
	AZ	1.38	35	1.97	50	1.63	2.23	0.60	3/8-24 UNF

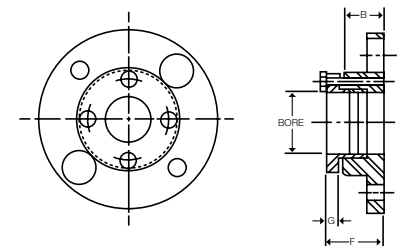

NOTE: AC and AL Hubs do not carry full torque capacity. Please consult engineering.

Form-Flex® G-Series and Torsiflex-i Hub Options

CLAMP HUB

PROVIDED WITH STRAIGHT BORE AND KEYWAY

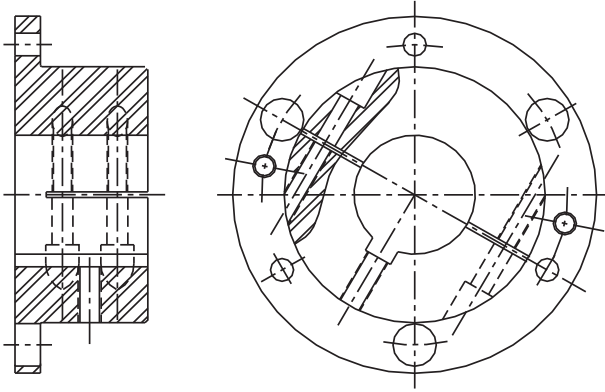

EXTERNAL LOCKING ELEMENT

USED WITH KEYLESS SHAFTS

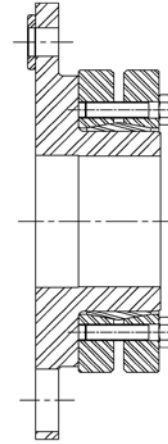

INTERNAL LOCKING ELEMENT

USED WITH KEYLESS SHAFTS

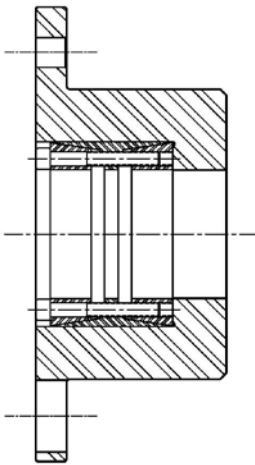

TAPER BORE WITH HYDRAULIC REMOVAL

USED WITH KEYLESS TAPERED SHAFTS

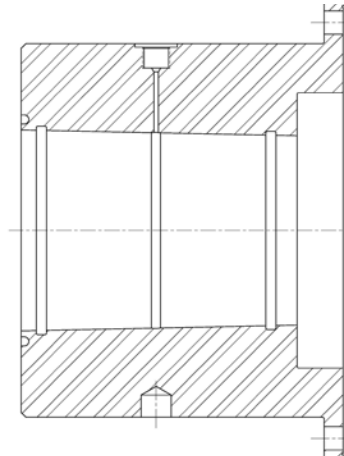

SPECIAL FLANGE ADAPTERS

DESIGNED TO MATE WITH ANY CUSTOM FLANGE

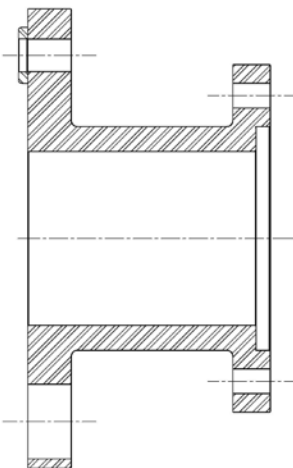

OVERSIZE HUB DESIGN

FOR INCREASED BORE CAPACITY

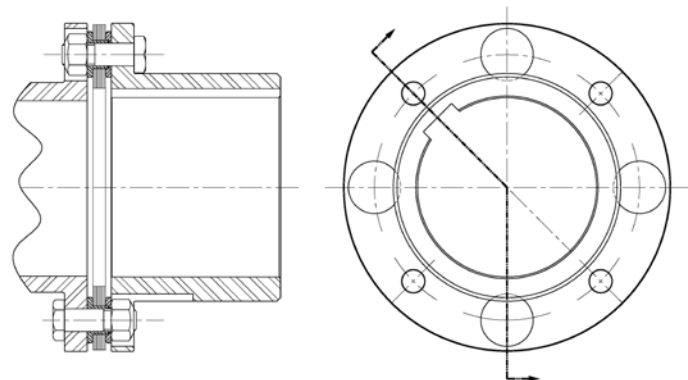

Coupling Design Options and Special Applications

ELECTRICAL INSULATION SPACER WITH SPLINE BORE AND EXTERNAL LOCKING ELEMENT

Two piece spacer design with e-glass composite tube separating the steel halves.

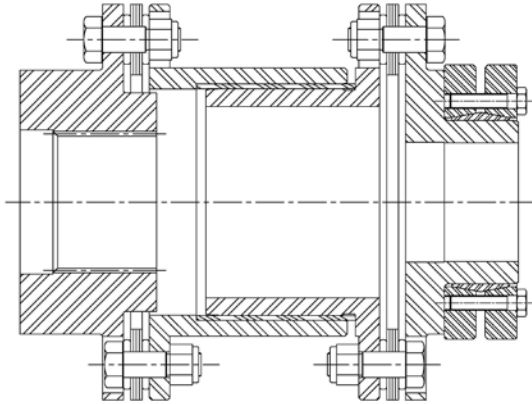

INERTIA RING ADDED TO TORSIONALLY TUNE COMPRESSOR SYSTEM

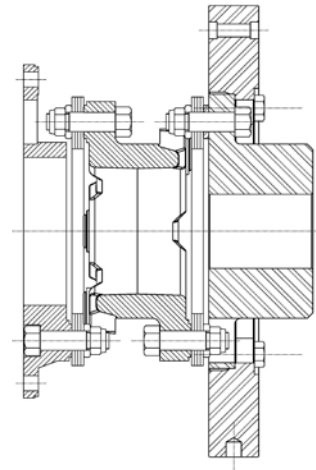

MODIFIED TORSIFLEX-i DESIGN WITH FLANGE TO FLANGE MOUNTING

Flanges designed to bolt to customer pilot and bolt pattern for test stand application.

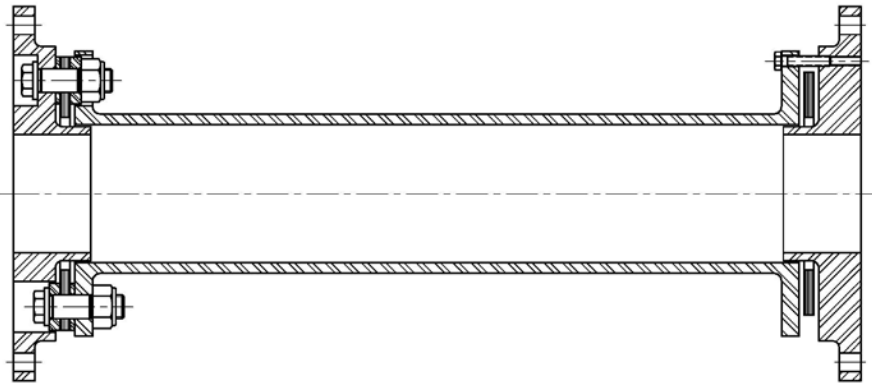

FLOATING SHAFT COUPLING WITH OVER SIZED TUBE FOR INCREASED STIFFNESS AND CRITICAL SPEED WITH CUSTOM FLANGE ADAPTER

Special features include oversize steel tube welded to bolted adapters for easy assembly, motor hub with integral brake disc, custom flange.

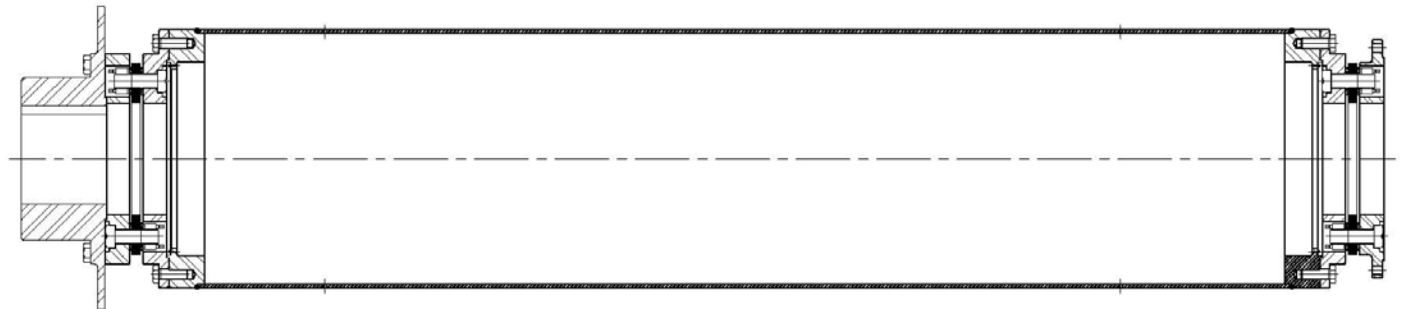

Coupling Design Options and Special Applications

MULTI-SHAFT ASSEMBLY FOR VERICAL PUMPING STATIONS USING COMPOSITE TUBE TECHNOLOGY

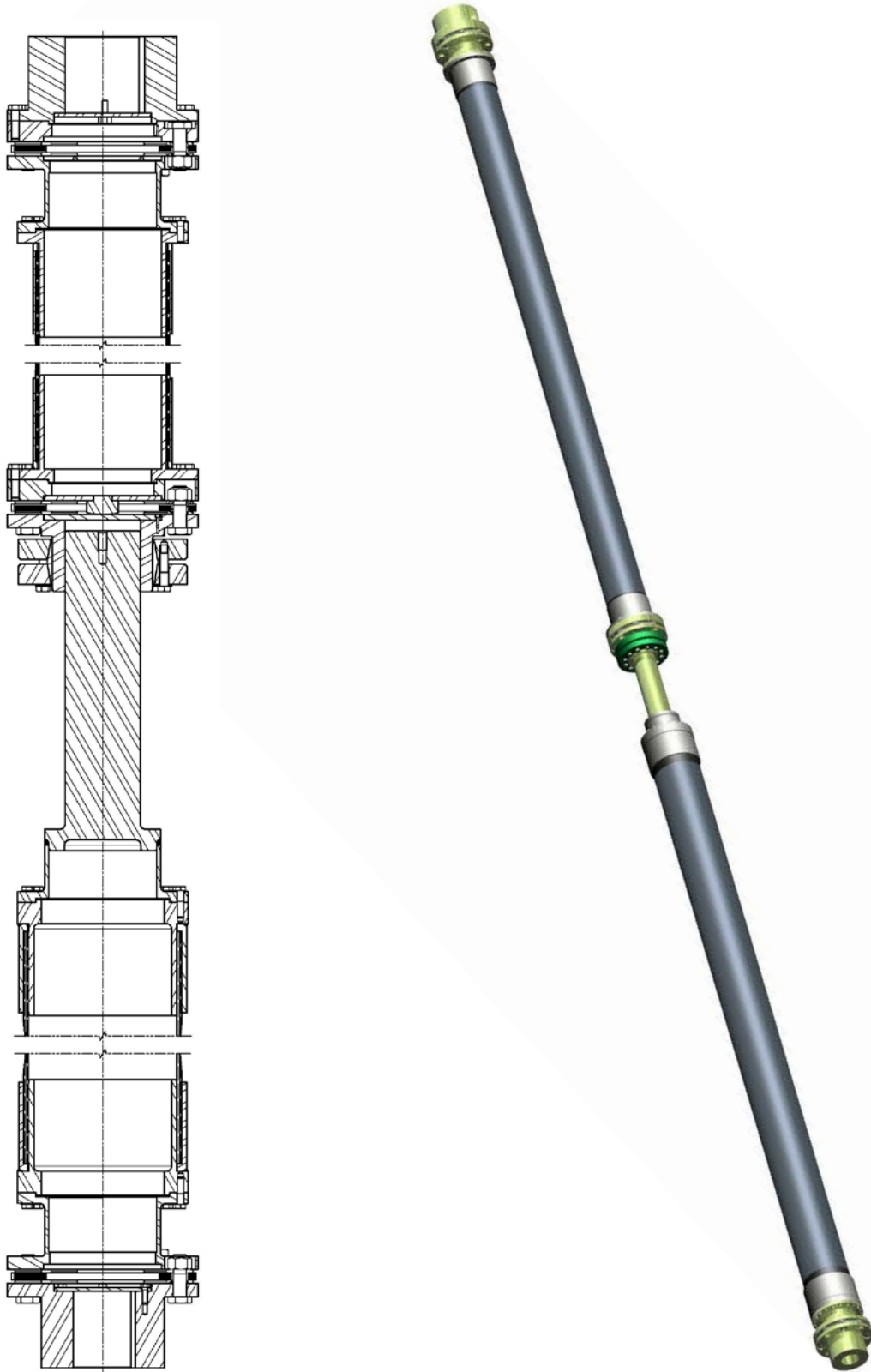

Disc, Bolt Thread and Tool Size Identification Chart

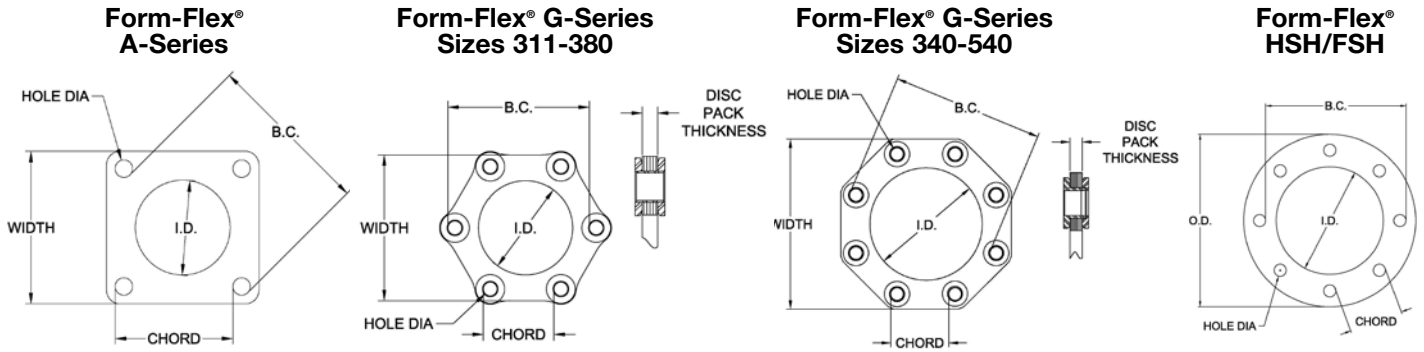

Coupling Series	Disc Size	Disc Dimensions (in)						Bolt				Nut	
		Width/OD	ID	Hole Dia.	B.C. Dia.	Chord	Disc Pack Thickness	Thread Dia. (in)	Thread Pitch	Thread Designation	HEX WAF (in)	HEX WAF (in)	Wrench Torque (lb-ft)
Form-Flex A-Series	5	1.83	1.00	0.25	1.88	1.31	0.06	0.250	28	1/4-28	0.438	0.438	8
	10	2.19	1.17	0.25	2.37	1.69	0.09	0.250	28	1/4-28	0.438	0.438	8
	15	2.54	1.28	0.31	2.69	1.88	0.12	0.313	24	5/16-24	0.500	0.500	17
	20	2.84	1.65	0.31	3.12	2.19	0.14	0.313	24	5/16-24	0.500	0.500	17
	25	3.52	1.78	0.44	3.75	2.63	0.15	0.438	20	7/16-20	0.625	0.625	40
	30	4.01	2.01	0.50	4.25	3.00	0.21	0.500	20	1/2-20	0.750	0.750	58
Form-Flex G-Series	35	4.71	2.71	0.50	5.25	3.69	0.27	0.500	20	1/2-20	0.750	0.750	58
	311	4.78	3.58	0.39	4.86	2.44	0.20	0.313	24	5/16-24	0.500	0.500	22
	321	5.38	3.72	0.51	5.25	2.63	0.25	0.438	20	7/16-20	0.625	0.688	55
	332	6.00	3.87	0.64	5.81	2.88	0.32	0.563	18	9/16-18	0.813	0.813	120
	346	6.93	4.75	0.64	6.81	3.38	0.32	0.563	18	9/16-18	0.813	0.813	120
	380	8.05	5.06	0.87	7.48	3.75	0.39	0.750	16	3/4-16	1.125	1.125	288
	340	7.50	4.91	0.63	6.75	2.56	0.24	0.500	20	1/2-20	0.875	0.875	75
	412	9.61	6.10	1.00	8.50	3.25	0.39	0.750	16	3/4-16	1.250	1.250	250
	419	11.01	7.00	1.14	9.75	3.75	0.50	1.000	14	1-14	1.625	1.625	450
	424	13.49	8.89	1.20	12.01	4.63	0.50	1.000	14	1-14	1.625	1.625	450
	444	15.06	9.60	1.44	13.19	5.06	0.57	1.125	12	1 1/8-12	1.813	1.813	840
	456	16.57	10.66	1.56	14.57	5.56	0.69	1.250	12	1 1/4-12	2.000	2.000	1,095
	483	17.90	11.54	1.67	15.75	6.00	0.77	1.375	12	1 3/8-12	2.188	2.188	1,240
	511	20.35	13.50	1.74	18.06	6.94	0.93	1.500	12	1 1/2-12	2.375	2.364	1,640
Form-Flex HSH/FSH	520	23.19	14.59	2.21	20.20	7.75	1.14	1.875	12	1 7/8-12	3.000	0.438	108
	525	24.95	15.64	2.35	21.70	8.31	1.20	2.000	12	2-12	3.125	0.438	124
	530	26.12	16.34	2.50	22.70	8.69	1.26	2.125	12	2 1/8-12	3.375	0.438	141
	540	31.21	21.15	2.65	28.05	10.75	1.58	2.250	10	2 1/4-12	3.750	0.563	196
	22	5.625	3.855	0.3275	4.7505	1.81	0.18	0.313	24	5/16-24	0.500	0.500	25
	26	6.565	4.400	0.4055	5.5010	2.13	0.22	0.375	24	3/8-24	0.563	0.563	30
	31	7.750	5.250	0.4680	6.5000	2.50	0.25	0.438	20	7/16-20	0.625	0.625	40
	35	8.625	5.750	0.5315	7.2500	2.75	0.29	0.500	20	1/2-20	0.813	0.750	70
	37	9.625	6.312	0.6265	8.0000	3.06	0.33	0.563	18	9/16-18	0.938	0.875	95
	42	10.500	6.750	0.6885	8.6250	3.31	0.31	0.625	18	5/8-18	1.063	0.938	125
	45	11.250	7.250	0.7505	9.2500	3.56	0.38	0.625	18	5/8-18	1.125	1.063	150
	50	12.813	8.500	0.8755	10.5000	4.00	0.47	0.750	16	3/4-16	1.250	1.250	210
	55	14.375	9.000	1.0005	11.7500	4.50	0.54	0.875	14	7/8-14	1.375	1.438	320
	60	15.938	9.938	1.1270	13.0000	5.00	0.59	1.000	14	1-1/4	1.625	1.625	450
70	18.125	11.125	1.3120	14.7500	5.63	0.78	1.125	12	1 1/8-12	1.750	1.813	575	
75	19.720	12.000	1.4380	16.0000	6.13	0.80	1.250	12	1 1/4-12	1.938	2.000	830	
80	21.438	13.125	1.5630	17.3760	6.63	0.81	1.375	12	1 3/8-12	2.125	2.188	1000	
85	22.875	14.000	1.7505	18.5000	7.06	0.88	1.500	12	1 1/2-12	2.500	2.375	1400	
92	24.875	15.000	1.8760	20.0000	7.63	1.01	1.500	12	1 1/2-12	2.500	2.375	1400	
92HT	24.875	15.000	1.8760	20.0000	7.63	1.01	1.750	12	1 3/4-12	2.500	2.750	2400	

Application Data Sheet

Project Ref: _____
 Company: _____ Date: _____
 Contact: _____ Email: _____
 Replacing: _____ Phone #: _____

SECTION I - DRIVER	Electric Motor <input type="checkbox"/> ; Engine <input type="checkbox"/> - # Cylinders _____ ; Turbine <input type="checkbox"/> ; Other _____
HP: _____	KW: _____ Normal Torque: _____ Lb-in[] Nm[]
Rated Speed: _____	Max Torque: _____ Lb-in[] Nm[]
Operating Speed: _____	Breakdown Torque: _____ Lb-in[] Nm[]

SECTION II - DRIVEN	Description: _____
Load Application: Non-Pulsating <input type="checkbox"/> Medium Pulsating <input type="checkbox"/> Heavy Pulsating <input type="checkbox"/> Smooth <input type="checkbox"/> Light Shock <input type="checkbox"/> Heavy Shock <input type="checkbox"/>	

SECTION III - COUPLING APPLICATION	Min Service Factor: _____
Temperature Range: _____ to _____ °C <input type="checkbox"/> or °F <input type="checkbox"/>	Hydraulic Removal: Yes <input type="checkbox"/> No <input type="checkbox"/>
Specification: API671 <input type="checkbox"/> Edition _____ ; API610 <input type="checkbox"/> Edition _____ ; Other _____	
Balance: Cplg <input type="checkbox"/> Hubs <input type="checkbox"/> Spacer <input type="checkbox"/>	Balance Specification _____

SECTION IV - DIMENSIONAL DATA	Distance Between Shaft Ends (DBSE): _____ IN <input type="checkbox"/> MM <input type="checkbox"/>
Taper Shaft & Keyway Data	
Driver	Driven
Shaft Dia (Straight): _____	_____
Shaft Dia L.E. (Taper): _____	_____
Taper Ratio _____	_____
Keyway Size: Width _____ Depth _____	Width _____ Depth _____
KW Depth Across Bore: _____	_____

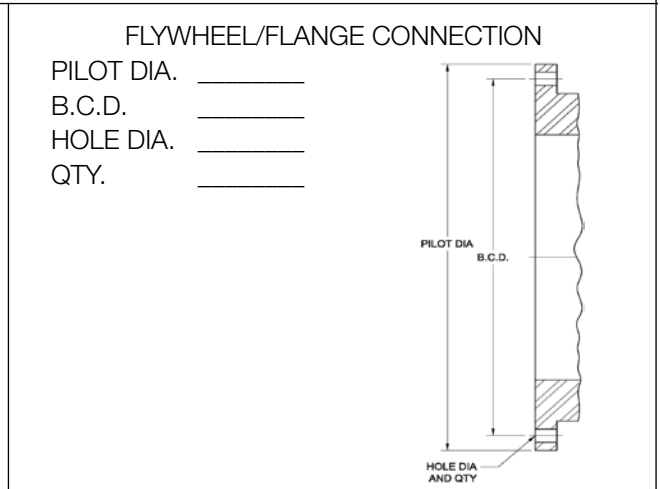
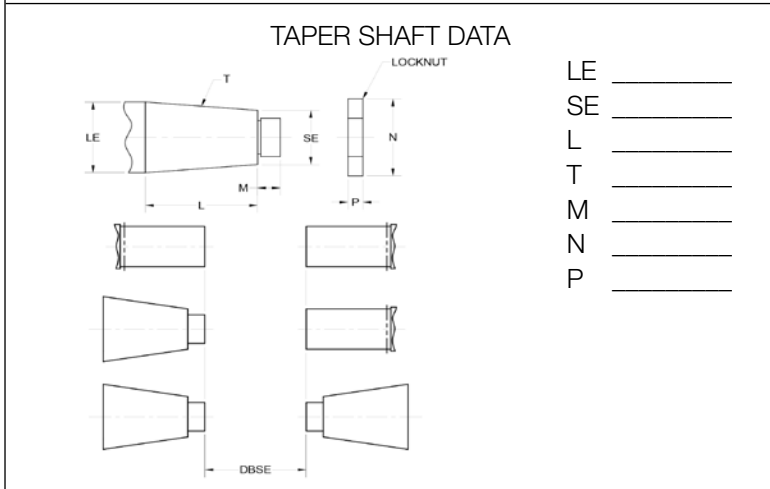

STANDARD ADAPTER SIZES

Size	O.D. (in)	SAE Bolting			HD Bolting		
		P.C.D. (in)	Hole Qty.	Hole Size (in)	P.C.D. (in)	Hole Qty.	Hole Size (in)
10	10.375	9.625	6	0.406	9.500	8	0.469
12	12.375	11.625	8	0.406	11.500	8	0.531
14	13.875	13.125	8	0.406	12.500	8	0.656
18	18.375	17.250	8	0.531	16.750	8	0.781
20	20.375	19.250	8	0.531	18.500	8	0.906
22	22.500	21.375	6	0.656	20.500	8	1.031
26	26.500	25.250	12	0.656	24.500	12	1.031
28	28.875	27.250	12	0.781	26.875	12	1.031

Application Data Sheet

Additional Comments: _____

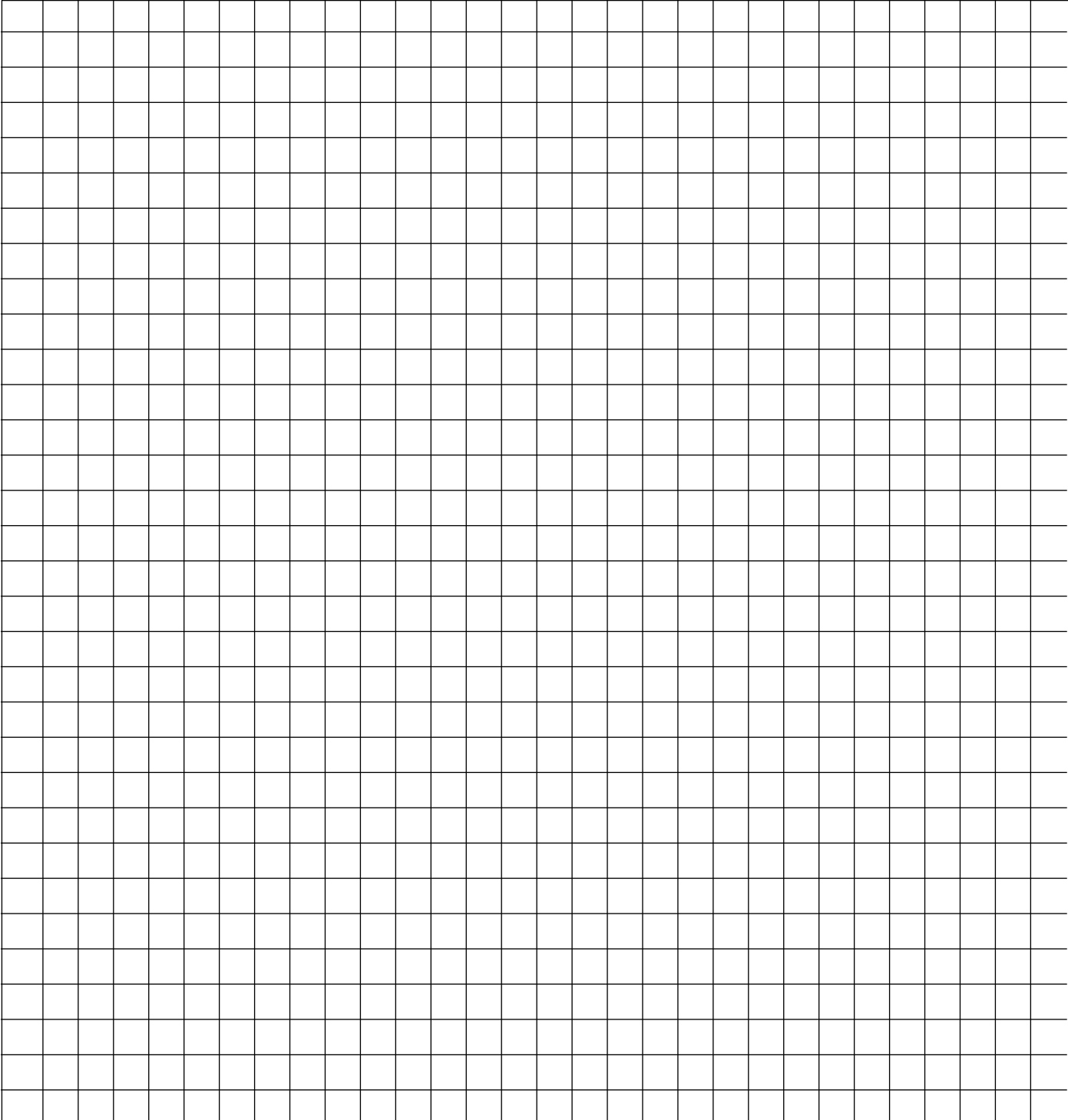

Sketch Area

Rigid Couplings

F7

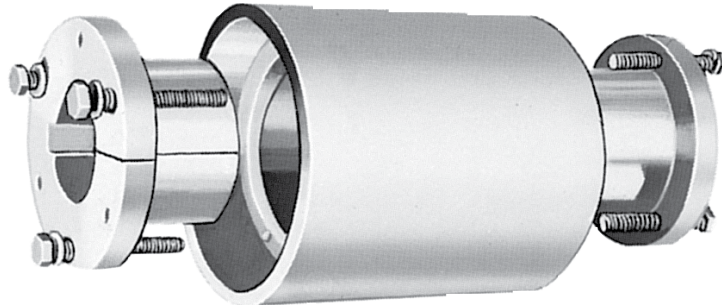
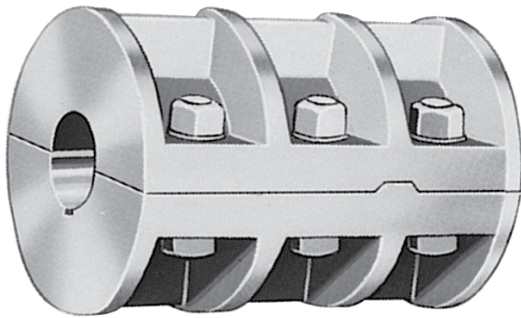

AVS Series Couplings

AVS Series (Adjustable Vertical Spacer)

- Coupling used for vertical turbine pumps
- No flexible element
- Integral “nut” used for infinite adjustment of pump turbine spacing

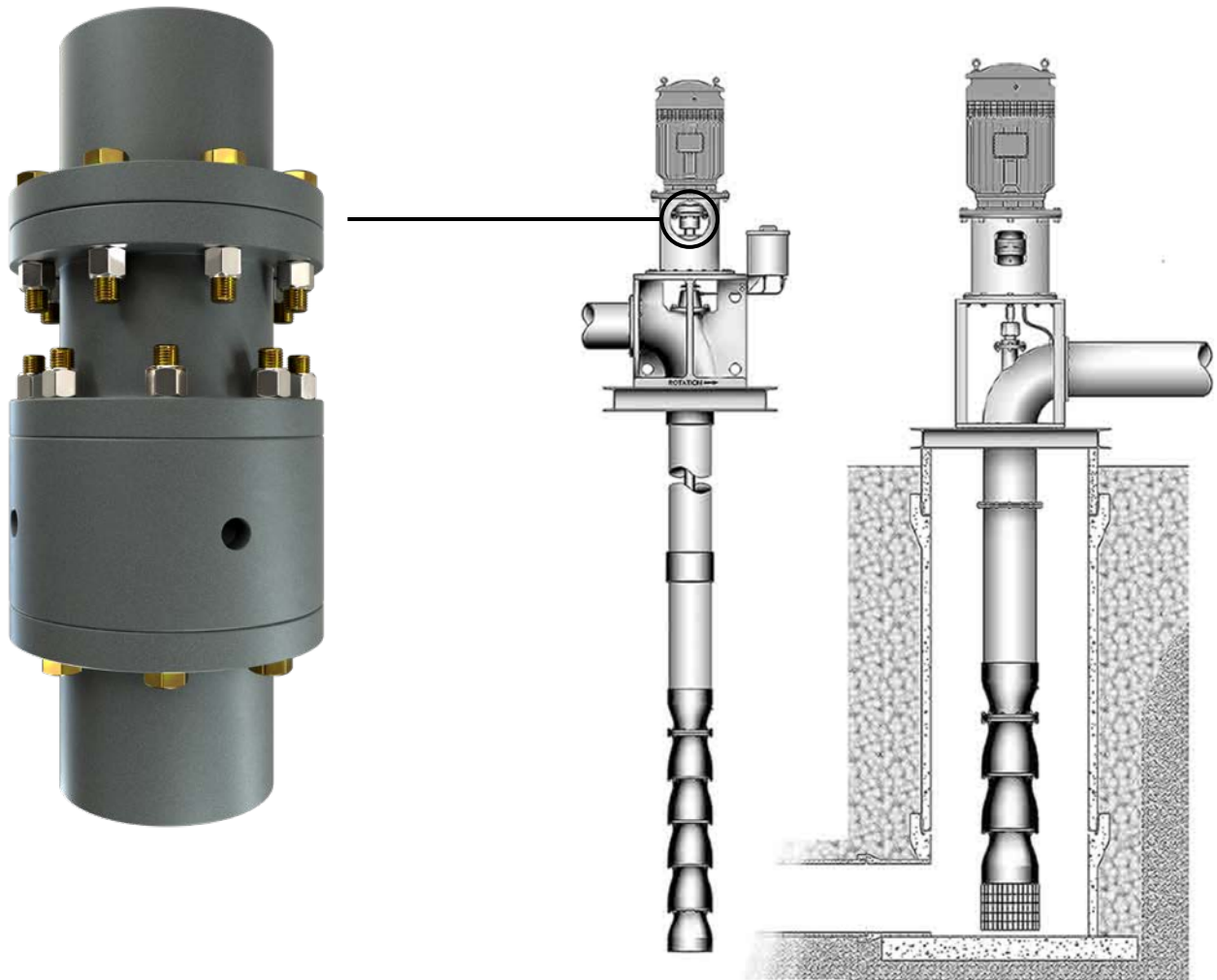

Vertical Adjustable Rigid Coupling AVS Series

Dimensions



- Major components are AISI 1045 steel
- Grade 8, Zinc Plated Hardware
- Meets AGMA 8 balance
- Component balance is optional
- Zinc Phosphate coated hubs, spacer and adjuster nut

DIMENSIONS						
NEMA SIZE	N	V	U	EU	G	M
182HP 184HP	.25	3.00	1.125	0.875	.377 .375	.75
213HP 215HP	.25	3.00	1.125	0.875	.377 .375	.75
254HP 256HP	.25	3.00	1.125	0.875	.377 .375	.75
284HP 286HP	.25	3.00	1.125	0.875	.377 .375	.75
324HP 326HP	.38	4.75	1.625	1.250	.377 .375	.75
364HP 365HP	.375	4.50	1.625	1.250	.377 .375	.75

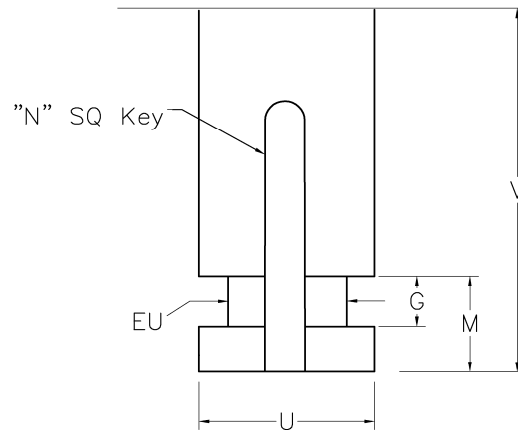

SIZE	RATED TORQUE		PEAK O/L TORQUE (LB-IN)	THRUST CAPACITY (LBS)	WEIGHT (LBS) (1)		WR ² (LB/IN ²) (1)		BOLT TIGHTEN TORQUE (FT-LB)	BOLT PER FLANGE	BOLT LENGTH (IN)		BOLT DIA. (IN)
	TORQUE (LB-IN)	HP/100 RPM			D MIN.	PER INCH ADDER	D MIN.	PER INCH ADDER			PUMP END	MOTOR END	
114	1,701	2.7	3,403	4,500	6.69	0.26	7.18	0.16	11	4	2.50	1.25	0.25
134	5,042	8.0	10,084	11,000	14.13	0.61	27.5	0.74	24	6	3.00	1.50	0.31
214	11,281	17.9	21,209	28,500	28.7	1.06	93.6	1.95	75	6	4.00	2.13	0.50
234	21,302	33.8	37,279	28,500	49.4	1.66	223	4.71	84	6	5.75	2.13	0.50
318	27,983	44.4	55,966	28,500	62.4	1.92	338	7.12	97	6	6.00	2.38	0.50
338	35,924	57	63,586	38,000	73.9	2.42	438	9.67	97	8	6.00	2.38	0.50
414	68,697	109	137,395	66,000	139	3.43	1,456	23.03	300	6	7.00	2.88	0.75
512	195,378	310	293,066	159,000	260	5.78	4,484	62.49	733	8	6.50	3.50	1.00
612	254,621	404	509,242	199,000	374	7.11	8,174	115.58	733	10	6.25	4.00	1.00
778	448,738	712	897,476	278,000	714	9.62	21,558	226.01	733	14	9.75	6.00	1.00
918	723,527	1,148	1,447,054	294,000	1,074	12.50	41,944	400.47	1,025	12	10.00	6.25	1.13
1100	1,363,861	2,164	2,727,722	352,000	1,816	16.65	101,100	780.89	1,025	12	11.50	7.25	1.13

1. Weight and WR² are calculated for couplings with DBSE = D std. and hubs at maximum bore size.
 2. Consult factory for torsional stiffness.

Vertical Adjustable Rigid Coupling AVS Series

Dimensions

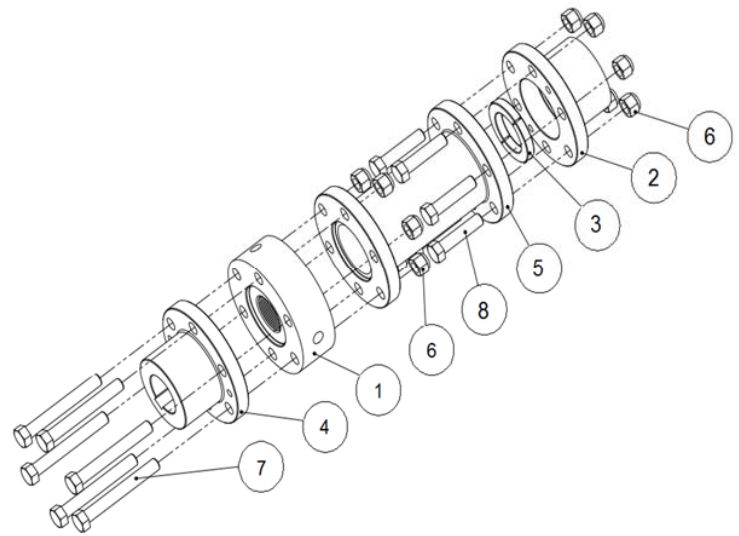
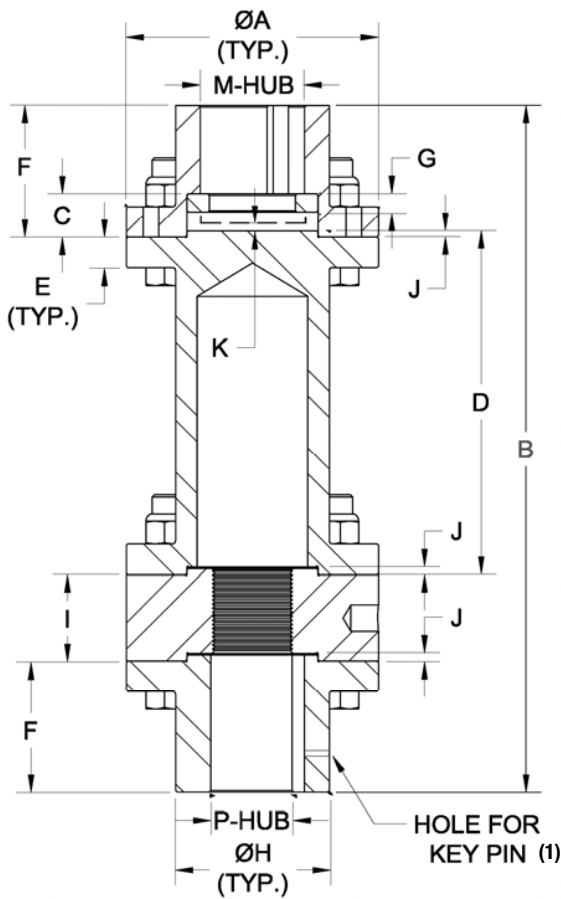

ITEM	DESCRIPTION
1	Adjusting Nut (2)
2	Motor Hub
3	Split Ring
4	Pump Hub
5	Spacer
6	All Steel Lock Nut
7	Pump End Bolt
8	Motor End Bolt

SIZE	MAX BORES		DIMENSIONS (IN)												
	P-HUB (IN) (4)	M-HUB (IN) (5)	A	B		C	D		E	F	G	H	I	J	K
				MIN	STD		MIN	STD							
114	1.250	1.125	3.00	6.75	9.56	0.89	1.63	4.44	0.38	2.00	0.375	1.75	1.25	0.125	0.016
134	1.750	1.688	4.00	7.63	10.31	0.89	1.75	4.44	0.44	2.25	0.375	2.50	1.50	0.125	0.016
214	2.250	2.125	5.13	9.63	11.44	0.89	2.63	4.44	0.63	2.69	0.375	3.13	1.75	0.125	0.016
234	2.750	2.625	5.88	11.88	13.69	0.89	2.63	4.44	0.63	2.94	.375/.50	3.88	3.50	0.125	0.016
318	3.125	2.938	6.38	13.13	14.69	0.89	2.88	4.44	0.75	3.44	.375/.50	4.38	3.50	0.125	0.016
338	3.375	3.250	6.75	14.25	15.81	0.89	2.88	4.44	0.75	4.00	.375/.50	4.63	3.50	0.125	0.016
414	4.250	3.938	8.94	15.75	17.06	0.89	3.13	4.44	0.81	4.38	.375/.50	5.88	4.00	0.125	0.016
512	5.500	5.125	11.75	19.50	20.38	1.38	4.50	5.00	1.00	6.00	.500/.750	7.50	3.00	0.250	0.125
612	6.500	6.438	13.25	25.38	26.25	1.63	4.75	5.00	1.13	9.25	0.625	9.00	2.38	0.250	0.125
778	7.875	7.500	15.00	31.94	33.13	1.94	7.06	7.50	2.25	10.75	0.750	10.75	3.69	0.313	0.125
918	9.125	9.000	17.25	37.00	41.50	1.94	7.31	7.50	2.25	15.00	0.750	12.50	3.56	0.313	0.125
1100	11.000	10.938	20.50	48.94	49.89	1.94	8.31	8.50	2.75	18.38	0.750	15.00	4.19	0.313	0.125

- Key Pin not included.
- Adjuster Nut can be left or right hand thread.
- Altra Couplings recommends coupling selection based on bore sizes and verify that torque service factor is a minimum of 1.25.
- Standard hub bore is for AGMA Clearance fit, but Interference fit is available upon request.
- Standard keyways per AGMA Commercial fit (Imperial), and Normal fit (Metric).

Vertical Rigid Close Coupling AVS Series

Dimensions

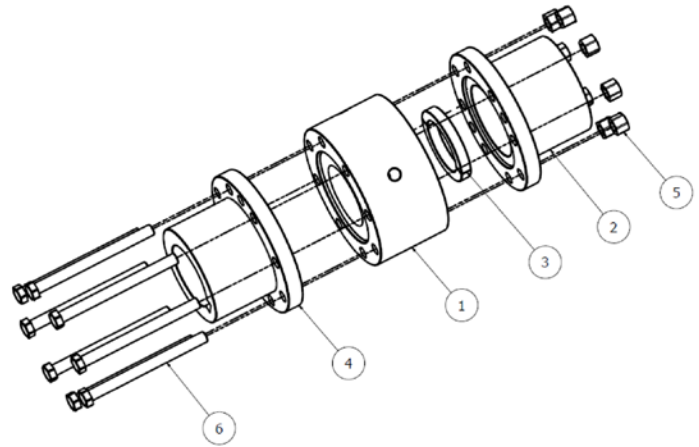
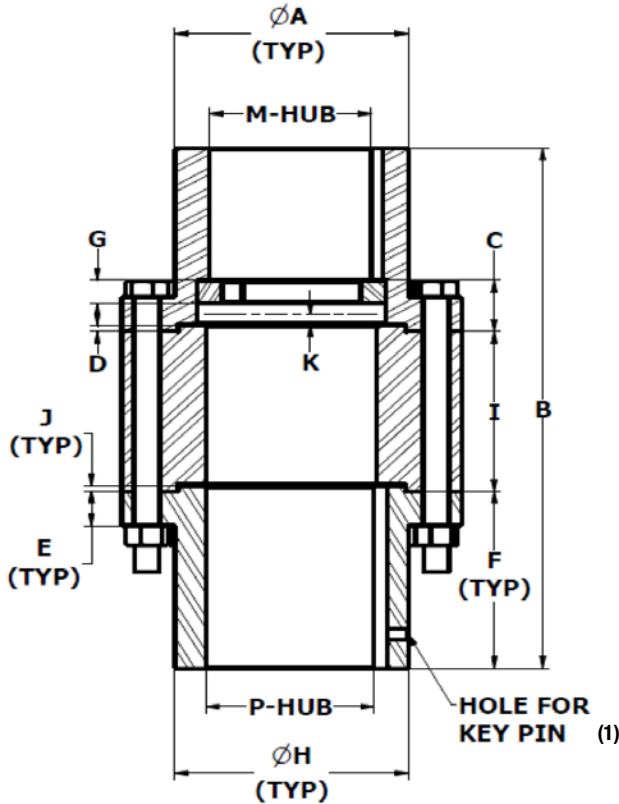

ITEM	DESCRIPTION
1	Adjusting Nut (2)
2	Motor Hub
3	Split Ring
4	Pump Hub
5	All Steel Lock Nut
6	Pump End Bolt

SIZE	MAX BORES		WEIGHT (LBS) (3)	WR ² (LB-IN ²) (3)	DIMENSIONS (IN)										
	P-HUB	M-HUB			A	B	C	D	E	F	G	H	I	J	K
	(IN)(4)	(IN)(5)													
114	1.250	1.125	4.39	4.89	3.00	5.25	0.89	0.125	0.38	2.00	0.375	1.75	1.25	0.125	0.016
134	1.750	1.688	9.21	18.66	4.00	6.00	0.89	0.125	0.44	2.25	0.375	2.50	1.50	0.125	0.016
214	2.250	2.125	18.4	62	5.13	7.13	0.89	0.125	0.63	2.69	0.375	3.13	1.75	0.125	0.016
234	2.750	2.625	35.4	166	5.88	9.38	0.89	0.125	0.63	2.94	.375/.50	3.88	3.50	0.125	0.016
318	3.125	2.938	45.0	250	6.38	10.38	0.89	0.125	0.75	3.44	.375/.50	4.38	3.50	0.125	0.016
338	3.375	3.250	53.4	324	6.75	11.50	0.89	0.125	0.75	4.00	.375/.50	4.63	3.50	0.125	0.016
414	4.250	3.938	103	1097	8.94	12.76	0.89	0.125	0.81	4.38	.375/.50	5.88	4.00	0.125	0.016
512	5.500	5.125	187	3183	11.75	15.00	1.38	0.25	1.00	6.00	.500/.750	7.50	3.00	0.25	0.125
612	6.500	6.438	278	5899	13.25	20.88	1.63	0.25	1.13	9.25	0.625	9.00	2.38	0.25	0.125
778	7.875	7.500	499	14834	15.00	25.19	1.94	0.313	2.25	10.75	0.75	10.75	3.69	0.313	0.125
918	9.125	9.000	796	30369	17.25	33.56	1.94	0.313	2.25	15.00	0.75	12.50	3.56	0.313	0.125
1100	11.000	10.938	1359	73973	20.50	40.95	1.94	0.313	2.75	18.38	0.75	15.00	4.19	0.313	0.125

1. Key pin not included
2. Adjuster Nut can be left or right hand thread
3. Weight and WR² calculated with hubs at max bore
4. Standard hub bore is for AGMA Clearance fit, but Interference fit is available upon request.
5. Standard keyways per AGMA Commercial fit (Imperial), and Normal fit (Metric).
6. Altra Couplings recommends coupling selection based on bore sizes and verify that torque service factor is a minimum of 1.25.

Selecting the right coupling is fast and easy.

WWW.TBWOODS.COM/COUPLING-SELECTOR.ASP

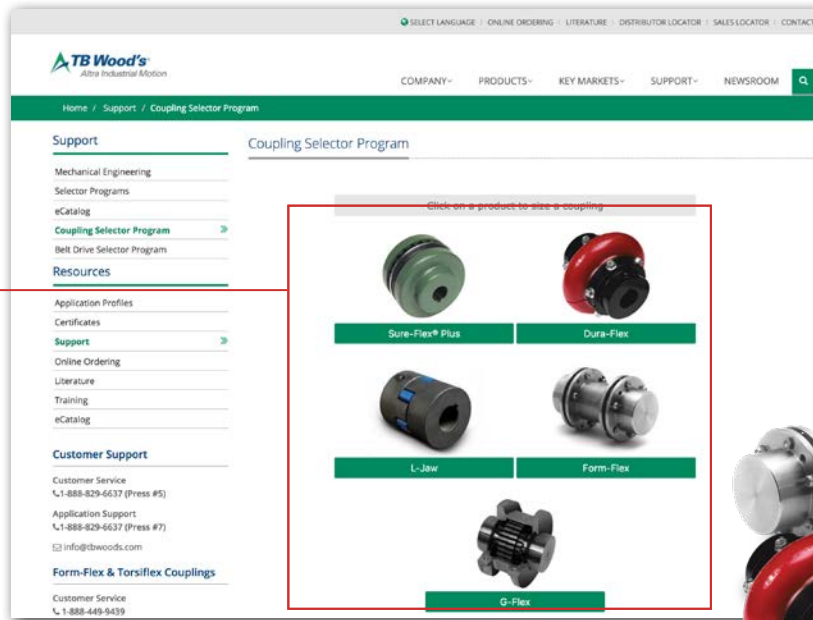

Coupling Selection

The Coupling Selector Program can be used for Sure-Flex Plus®, Dura-Flex®, L-Jaw, G-Flex & Form-Flex® products.

Required Specifications

Select component types for a specific application or select all for many options.

Application Data

Input data specific to the application for selecting the correct size coupling.

Select Coupling

Once data is entered, the coupling can be selected.

Start Over

Erase information to start over.

Sure-Flex® Plus Coupling Selection

[Instructions and Contact Info](#)
[Sure-Flex Plus Coupling Details](#)

Required Specifications

EPDM Sleeve Type
 General purpose
 Temp Range -30 to +275 F

NEOPRENE Sleeve
 Oil resistance, Non-flame
 Temp Range -0 to +200 F

HYTREL Sleeve
 High-torque rating
 Temp Range -65 to +250 F

Solid Sleeve Design

Split Sleeve Design

2-Piece Sleeve With Ring

S or J Type Flange

B Type Bushed Flange

C Type Clamp Flange

Power: English (HP, in-lbs) Metric (kW, Nm)

Speed: rpm

Torque: in-lbs - Leave power blank to enter torque manually.

Driver End Nominal Shaft Diameter: in mm

Driven End Nominal Shaft Diameter: in mm

Driver End Equipment Type: AC MOTOR NEMA A or B

Driven End Equipment Type: PUMPS (Centrifugal, Axial)

Application Service Factor: 1.25

Special Requirements as Needed

Distance Between Shaft Ends: in mm

Maximum Overall Length: in mm

Maximum Outside Diameter: in mm

Hide List Price Dollar Pound Euro

List Price Modifier: 1 (Decimal 0 to 1)

Customer Name:

Quote Number:

Instructions & Contact Info

This brochure is available for reference by clicking the instruction link.

Change Product

Return to the Coupling Type Selection page.

Altra Industrial Motion

TB Wood's Facilities

North America

USA

440 North Fifth Avenue
Chambersburg, PA 17201 - USA
888-829-6637 * 717-264-7161
Belted Drives and Elastomeric Couplings

Customer Service

1-888-829-6637 (Press #5)

For Application Support

1-888-829-6637 (Press #7)

2000 Clovis Barker Road
San Marcos, TX 78666 - USA
1-888-449-9439
General Purpose Disc Couplings

Customer Service

1-888-449-9439

4970 Joule St
Reno, NV 89502 - USA
775-857-1800

Canada

9779 45 Ave NW
Edmonton, AB T6E 5V8 - Canada
+1 780-439-7979

6305 Danville Road
Mississauga, ON L5T 2H7 - Canada
1-800-829-6631

1073 Rue Bégin
Saint-Laurent, QC H4R 1V8 - Canada
+1 514-332-4812

Mexico

Comisión Federal de Electricidad 850,
Industrial San Luis,
San Luis, S.L.P., 78395 - Mexico
+52 444 137 1500

Europe

Merchant Drive, Hertford
Hertfordshire SG13 7BL - England
+44(0)1992 501900
Elastomeric Couplings

The Brands of Altra Industrial Motion

Couplings

Ameridrives
www.ameridrives.com

Bibby Turbobox
www.bibbyturbobox.com

Guardian Couplings
www.guardiancouplings.com

Huco
www.huco.com

Lamiflex Couplings
www.lamiflexcouplings.com

Stromag
www.stromag.com

TB Wood's
www.tbwoods.com

G geared Cam Limit Switches

Stromag
www.stromag.com

Electric Clutches & Brakes

Inertia Dynamics
www.idicb.com

Matrix
www.matrix-international.com

Stromag
www.stromag.com

Warner Electric
www.warnerelectric.com

Linear Products

Warner Linear
www.warnerlinear.com

Engineered Bearing Assemblies

Kilian
www.kilianbearings.com

Heavy Duty Clutches & Brakes

Industrial Clutch
www.indclutch.com

Twiflex
www.twiflex.com

Stromag
www.stromag.com

Svendborg Brakes
www.svendborg-brakes.com

Wichita Clutch
www.wichitaclutch.com

Belted Drives

TB Wood's
www.tbwoods.com

Gearing

Bauer Gear Motor
www.bauergears.com

Boston Gear
www.bostongear.com

Delroyd Worm Gear
www.delroyd.com

Nuttall Gear
www.nuttallgear.com

Overrunning Clutches

Formsprag Clutch
www.formsprag.com

Marland Clutch
www.marland.com

Stieber
www.stieberclutch.com

Neither the accuracy nor completeness of the information contained in this publication is guaranteed by the company and may be subject to change in its sole discretion. The operating and performance characteristics of these products may vary depending on the application, installation, operating conditions and environmental factors. The company's terms and conditions of sale can be viewed at <http://www.altramotion.com/terms-and-conditions/sales-terms-and-conditions>. These terms and conditions apply to any person who may buy, acquire or use a product referred to herein, including any person who buys from a licensed distributor of these branded products.

©2018 by TB Wood's LLC. All rights reserved. All trademarks in this publication are the sole and exclusive property of TB Wood's LLC or one of its affiliated companies.



www.tbwoods.com

P-1690-TBW 4/18