



Main

Range of product	Zelio Control
Product or component type	Industrial measurement and control relays
Relay type	Current measurement relay
Relay name	RM4J
Relay monitored parameters	Overcurrent or undercurrent detection
Time delay type	Adjustable 0.05...30 s
Power consumption in VA	1.9...3.3 VA AC
Measurement range	1...5 A current AC 1...5 A current DC 3...15 A current AC 3...15 A current DC 300...1500 mA current AC 300...1500 mA current DC
Contacts type and composition	2 C/O

Complementary

[Us] rated supply voltage	110...130 V AC, 50/60 Hz +/- 5 %
Control circuit voltage limits	0.85...1.1 U _c
Output contacts	2 C/O
Measuring cycle	<= 80 ms
Internal input resistance	0.006 Ohm 0.02 Ohm 0.06 Ohm
Permissible continuous overload	2 A 20 A 7 A
Permissible non repetitive overload	10 A for <= 3 s 100 A 15 A
Setting accuracy of the switching threshold	+/- 5 %

Switching threshold drift	<= 0.06 % per degree centigrade depending permissible ambient air temperature <= 0.5 % within the supply voltage range (0.85...1.1 Un)
Setting accuracy of time delay	10 P
Time delay drift	<= 0.07 % per degree centigrade depending on temperature <= 0.5 % within the supply voltage range (0.85...1.1 Un)
Hysteresis	5...30 % adjustable of current threshold setting
Marking	CE : EMC 89/336/EEC CE : LVD 73/23/EEC
Overvoltage category	III conforming to IEC 60664-1
[Ui] rated insulation voltage	500 V conforming to IEC
Supply disconnection value	> 0.1 Uc
Operating position	Any position without derating
Connections - terminals	Screw terminals 2 x 1.5 mm ² , flexible cable with cable end Screw terminals 2 x 2.5 mm ² , flexible cable without cable end
Tightening torque	0.6...1.1 N.m
Mechanical durability	30000000 cycles
[Ith] conventional free air thermal current	8 A
[Ie] rated operational current	2 A at 24 V DC-13 70 °C conforming to IEC 60947-5-1/1991 2 A at 24 V DC-13 70 °C conforming to VDE 0660 3 A at 115 V AC-15 70 °C conforming to IEC 60947-5-1/1991 3 A at 115 V AC-15 70 °C conforming to VDE 0660 3 A at 24 V AC-15 70 °C conforming to IEC 60947-5-1/1991 3 A at 24 V AC-15 70 °C conforming to VDE 0660 3 A at 250 V AC-15 70 °C conforming to IEC 60947-5-1/1991 3 A at 250 V AC-15 70 °C conforming to VDE 0660 0.1 A at 250 V DC-13 70 °C conforming to IEC 60947-5-1/1991 0.1 A at 250 V DC-13 70 °C conforming to VDE 0660 0.3 A at 115 V DC-13 70 °C conforming to IEC 60947-5-1/1991 0.3 A at 115 V DC-13 70 °C conforming to VDE 0660
Switching capacity in mA	10 mA at 12 V
Switching voltage	<= 440 V AC 250 V AC
Contacts material	90/10 silver nickel contacts
Number of cables	2
Width	45 mm
Height	78 mm
Depth	80 mm
Terminals description ISO n°1	(15-16-18)OC (25-26-28)OC (A1-A2)CO (C-B1-B2-B3)CO
Output relay state	Tripped if A measured > A set Tripped if V measured > V set
9 mm pitches	5
Product weight	0.204 kg

Environment

Electromagnetic compatibility	Electrostatic discharge - test level 6 kV, level 3 - contact discharge conforming to IEC 61000-4-2 Electrostatic discharge - test level 8 kV, level 3 - air discharge conforming to IEC 61000-4-2
Standards	EN/IEC 60255-6
Product certifications	CSA GL UL
Ambient air temperature for storage	-40...85 °C
Ambient air temperature for operation	-20...65 °C
Environmental characteristic	3K3
Relative humidity	15...85 % conforming to IEC 60721-3-3
Shock resistance	15 gn for 11 ms conforming to IEC 60255-21-1
IP degree of protection	IP20 (terminals) conforming to IEC 60529

	IP50 (casing) conforming to IEC 60529
Pollution degree	3 conforming to IEC 60664-1
Dielectric test voltage	2.5 kV
Non-dissipating shock wave	4.8 kV
Resistance to electrostatic discharge	6 kV contact conforming to IEC 61000-4-2 level 3 8 kV air conforming to IEC 61000-4-2 level 3
Resistance to electromagnetic fields	10 V/m conforming to IEC 61000-4-3 level 3
Resistance to fast transients	2 kV conforming to IEC 61000-4-4 level 3
Protection against electric shocks	2 kV : level 3 conforming to IEC 61000-4-5
Disturbance radiated/conducted	CISPR 11 group 1 - class A CISPR 22 - class A

Contractual warranty

Warranty period	18 months
-----------------	-----------

Current Measurement Relays

Dimensions

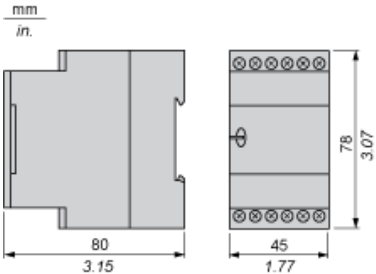

Current Measurement Relays

Rail mounting

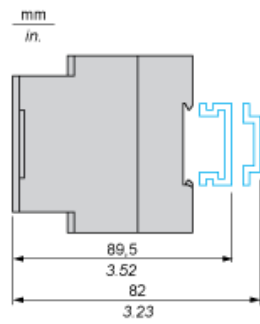

Screw fixing

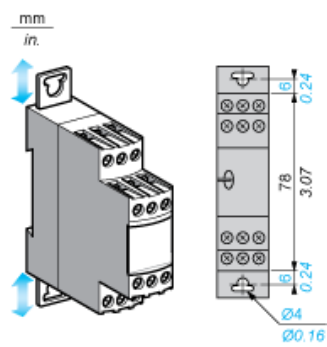

Current Measurement Relays

RM4JA01 Wiring Diagram

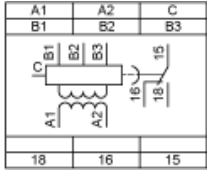

A1-A2 Supply voltage
B1, B2, B3 Currents to be measured (see table below)

Connection and current values to be measured	
B1-C	3...30 mA
B2-C	10...100 mA
B3-C	0.1...1 A

RM4JA31 Wiring Diagram

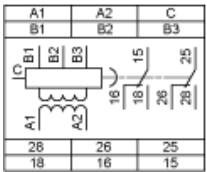

A1-A2 Supply voltage
B1, B2, B3 Currents to be measured (see table below)

Connection and current values to be measured	
B1-C	3...30 mA
B2-C	10...100 mA
B3-C	0.1...1 A

RM4JA32 Wiring Diagram

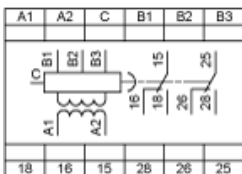

A1-A2 Supply voltage
B1, B2, B3 Currents to be measured (see table below)

Connection and current values to be measured	
B1-C	0.3...1.5 A
B2-C	1...5 A
B3-C	3...15 A

Application Schemes

Example: Detection of Blockage on a Crusher (Overcurrent Function)

Current measured ≤ 15 A

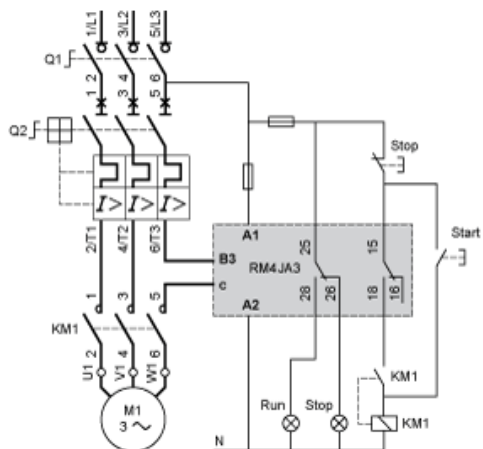

Current measured > 15 A

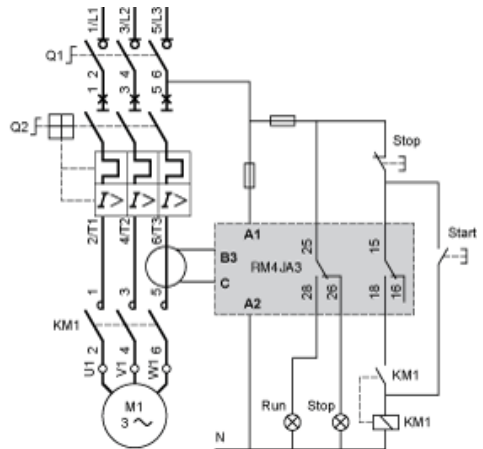

Electrical Durability and Load Limit Curves

AC Load

Curve 1: Electrical durability of contacts on resistive load in millions of operating cycles

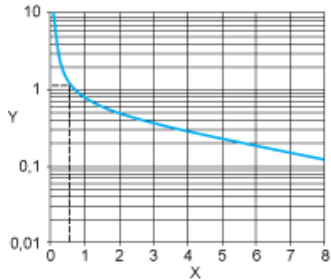

X Current broken in A
Y Millions of operating cycles

Curve 2: Reduction factor k for inductive loads (applies to values taken from durability Curve 1)

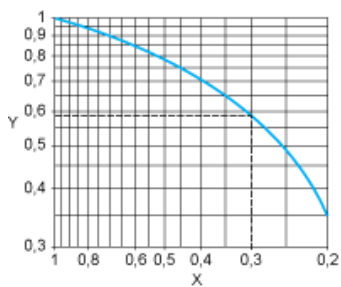

X Power factor on breaking (cos φ)
Y Reduction factor k

DC Load

Load limit curve

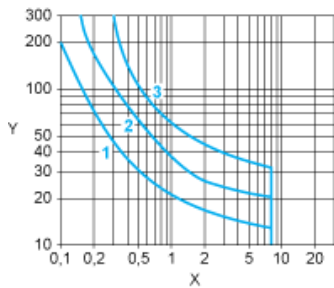

X Current in A
Y Voltage in V
1 L/R = 20 ms
2 L/R with load protection diode
3 Resistive load

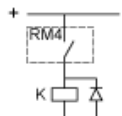

Function Diagram

Overcurrent Detection

Function ">"

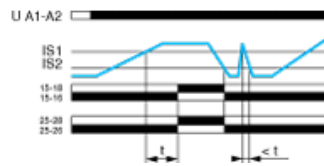

Legend

t Time delay

U A1-A2 Supply voltage

IS1 Setting current threshold

IS2 Current measured

15-18, 15-16; 25-28, 25-26 Output relays connections

Relay status: black color = energized.

Function Diagram

Undercurrent Detection

Function "<"

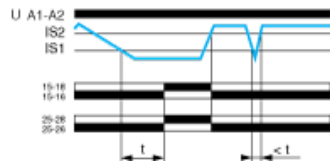

Legend

t Time delay

U A1-A2 Supply voltage

IS1 Setting current threshold

IS2 Current measured

15-18, 15-16; 25-28, 25-26 Output relays connections

Relay status: black color = energized.