

Operating Instructions

Series FD9000 Fuel Hose Reels

Low Pressure Model Numbers:

FD9200 OLP FD9300 OLP
FD9350 OLP FD9400 OLP
FD9450 OLP



Dimensions

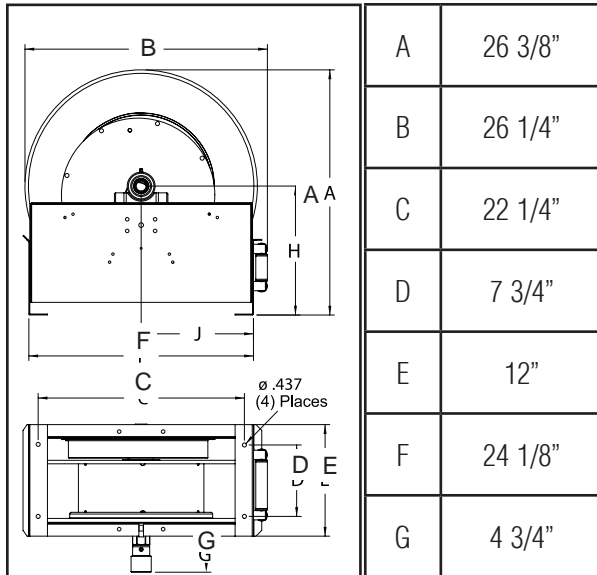

SAFETY

1. Do not use reel at higher pressures or temperatures than listed on the back of this bulletin.
2. Remove all spring tension before beginning disassembly process.
3. Reel spring motor case is permanently sealed. Any attempt to remove the spring motor may cause serious injury.

INSTALLATION:

The swivel union is packed separately in the reel carton, use teflon tape to assure a satisfactory seal. A flexible hose connection must be used between the hose reel inlet and the source of supply to prevent possible misalignment and binding. Non flexible connections will void the warranty, pressure rating of inlet hose must be equal to or more than the pressure rating of the reel. Consult factory for proper spring when installing reels above 16 ft.

LUBRICATION:

Hose reel spring and bearings are factory lubricated and require no further lubrication.

REPLACING HOSE:

1. Wind spool flange clockwise-facing swivel-until spring is tight.
2. Back off three turns and latch.
3. Insert hose through roller guide.
4. Connect hose fitting to female outlet ell.

ADJUSTMENTS:

To adjust spring tension, add or remove wraps of hose from the spool, one wrap at a time until desired tension is obtained.

REPAIRS:

Extensive repairs should be performed only by an authorized serviceman or factory to avoid damage which may void your warranty. Remove all spring tension before beginning disassembly process.

MODIFICATION:

Hose latching mechanism can be removed for constant tension applications.

Form# 835-696A Rev: 8/2015

Series FD9000 Fuel Hose Reels

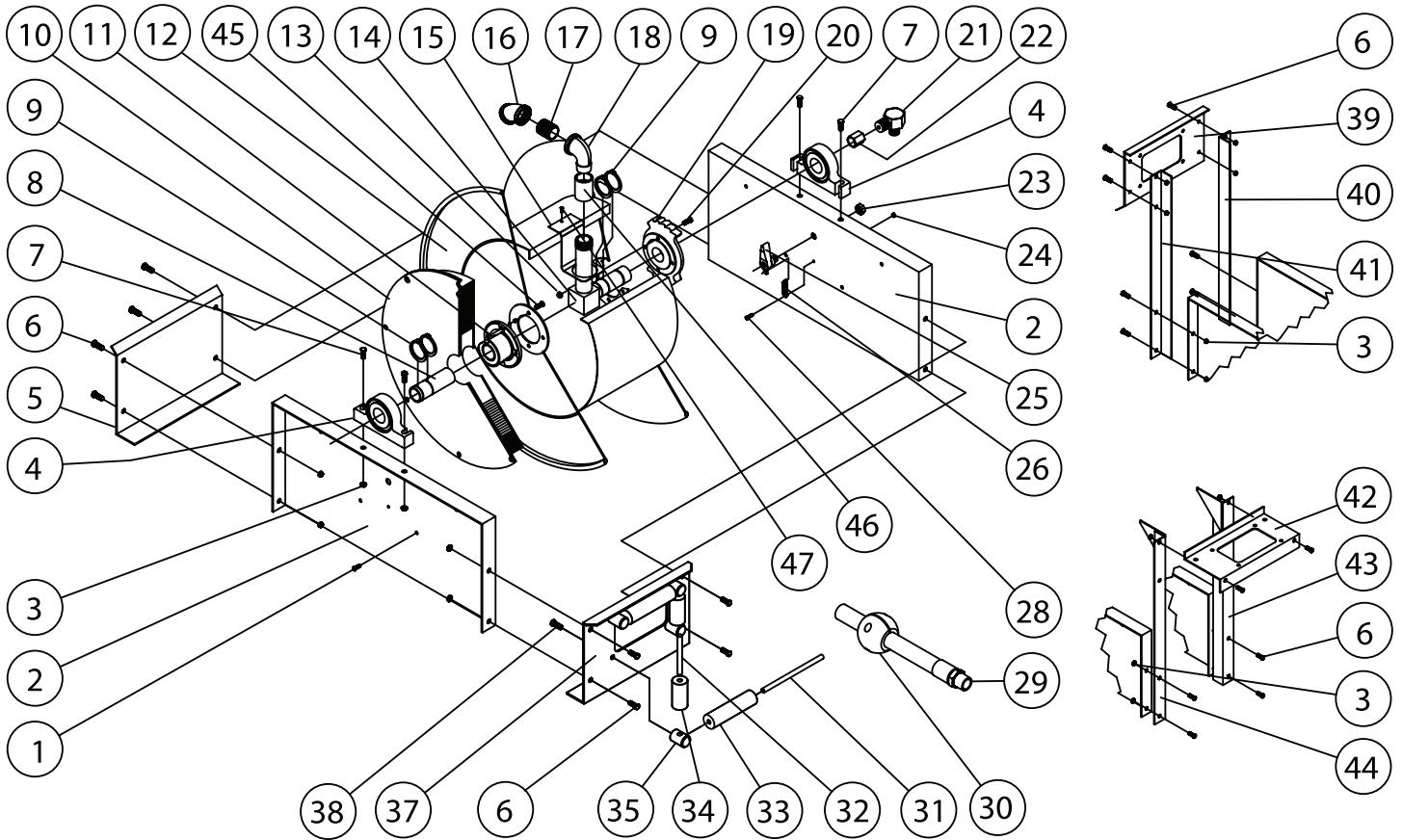

Item #	Description	# Req	FD9200 OLPBW	Item #	Description	# Req	FD9200 OLPBW
1	1/4-20 x 1/2" hex screw	4	S2-41	26	Latch spring	1	S260067-1
2	Side frame	2	270009	27	Latch bushing	1	S400012
3	3/8-16 hex flange nut	12	S281-6	28	10-32 x 7/8" screw	1	S20-110
4	Pillow block	2	S270058	29	Hose assembly	1	None
5	End frame support	1	270012	30	Hose bumper	1	None
6	3/8-16 x 5/8" mach. screw	8	S44-2	31	Guide roller pin - long	2	S270016
7	3/8-16 x 1 3/4" screw	4	S44-8	32	Guide roller pin - short	2	S270015
8	Main shaft assembly	1	602314	33	Guide roller	2	262436-5.468
9	Snap ring	6	S140-31	34	Guide roller	2	262436-2.968
10	Spring & case assembly	1	S270105	35	Guide roller post	4	S270014
11	Spring arbor	1	S270002	37	Hose guide roller plate	1	270011
12	Sheave assembly	1	270107	38	5/16-18 x 1/2" hex screw	4	S2-51
13	1/4-20 hex flange nut	8	S281-4	39	Guide roller plate SW	1	270045
14	1" Inlet tube	1	S270054	40	SW support bracket	1	270043
15	Hose outlet support	1	270029	41	SW support bracket	1	270042
16	45° Elbow	1	None	42	Guide roller plate TW	1	270044
17	Bushing	1	300080	43	TW support bracket	1	270041
18	90° Ell	1	270028	44	TW support bracket	1	270040
19	Latch ratchet hub	1	S270001	45	Self tapping screw	4	S328-29
20	1/4-20 x 5/8" hex screw	4	S4-42	46	Coupling	1	None
21	Swivel assembly	1	S600888-2	47	#10 x 3/8" self tap screw	1	S32-136
22	Coupling reducer	1	S289-5	--	Hose ID and length	--	None
23	1/2-20 hex flange nut	1	S280-8	--	Working pressure	--	500 PSI
24	10-32 x 3/8" nyloc nut	1	S82-15	--	Max. temperature	--	210 °F
25	Latch pawl assembly	1	S600018				

Series FD9000 Fuel Hose Reels

Item #	Description	# Req	FD9300 OLPBW	FD9350 OLPBW	FD9400 OLPBW	FD9450 OLPBW
1	1/4-20 x 1/2" hex screw	4	S2-41	S2-41	S2-41	S2-41
2	Side frame	2	270009	270009	270009	270009
3	3/8-16 hex flange nut	12	S281-6	S281-6	S281-6	S281-6
4	Pillow block	2	S270058	S270058	S270058	S270058
5	End frame support	1	270012	270012	270012	270012
6	3/8-16 x 5/8" mach. screw	8	S44-2	S44-2	S44-2	S44-2
7	3/8-16 x 1 3/4" screw	4	S44-8	S44-8	S44-8	S44-8
8	Main shaft assembly	1	602314	602314	602314	602314
9	Snap ring	6	S140-31	S140-31	S140-31	S140-31
10	Spring & case assembly	1	S270105	S270105	S270105	S270105
11	Spring arbor	1	S270002	S270002	S270002	S270002
12	Sheave assembly	1	270107	270107	270106	270106
13	1/4-20 hex flange nut	8	S281-4	S281-4	S281-4	S281-4
14	1" Inlet tube	1	S270054	S270054	S270054	S270054
15	Hose outlet support	1	270029	270029	270029	270029
16	45° Elbow	1	None	None	262452	262452
17	Bushing	1	270025	270025	None	None
18	90° Ell	1	270028	270028	262451	262451
19	Latch ratchet hub	1	S270001	S270001	S270001	S270001
20	1/4-20 x 5/8" hex screw	4	S2-42	S2-42	S2-42	S2-42
21	Swivel assembly	1	S602026-2	S602026-2	S600682-2	S600682-2
22	Coupling reducer	1	S289-6	S289-6	None	None
23	1/2-20 hex flange nut	1	S280-8	S280-8	S280-8	S280-8
24	10-32 x 3/8" nyloc nut	1	S82-15	S82-15	S82-15	S82-15
25	Latch pawl assembly	1	S600018	S600018	S600018	S600018
26	Latch spring	1	S260067-1	S260067-1	S260067-1	S260067-1
27	Latch bushing	1	S400012	S400012	S400012	S400012
28	10-32 x 7/8" screw	1	S20-110	S20-110	S20-110	S20-110
29	Hose assembly	1	None	600160-2	None	600451-50
30	Hose bumper	1	None	3-HR1005	None	4-HR1005
31	Guide roller pin - long	2	S270016	S270016	S270016	S270016
32	Guide roller pin - short	2	S270015	S270015	S270015	S270015
33	Guide roller	2	262436-5.468	262436-5.468	262436-5.468	262436-5.468
34	Guide roller	2	262436-2.968	262436-2.968	262436-2.968	262436-2.968
35	Guide roller post	4	S270014	S270014	S270014	S270014
37	Hose guide roller plate	1	270011	270011	270011	270011
38	5/16-18 x 1/2" hex screw	4	S2-51	S2-51	S2-51	S2-51
39	Guide roller plate SW	1	270045	270045	270045	270045
40	SW support bracket	1	270043	270043	270043	270043
41	SW support bracket	1	270042	270042	270042	270042
42	Guide roller plate TW	1	270044	270044	270044	270044
43	TW support bracket	1	270041	270041	270041	270041
44	TW support bracket	1	270040	270040	270040	270040
45	Self tapping screw	4	S328-29	S328-29	S328-29	S328-29
46	Coupling	1	None	None	262453	262453
47	#10 x 3/8" self tap screw	1	S32-136	S32-136	S32-136	S32-136
--	Hose ID and length	--	None	3/4" x 50'	None	1" x 50'
--	Working pressure	--	500 PSI	*50 PSI	500 PSI	*50 PSI
--	Max. temperature	--	210 °F	150 °F	210 °F	150 °F

*Models equipped with fuel grade hose. UL330 and ULC approved hose. 250 PSI minimum burst.