

MatTop Installation and Maintenance Manual

Issue 1

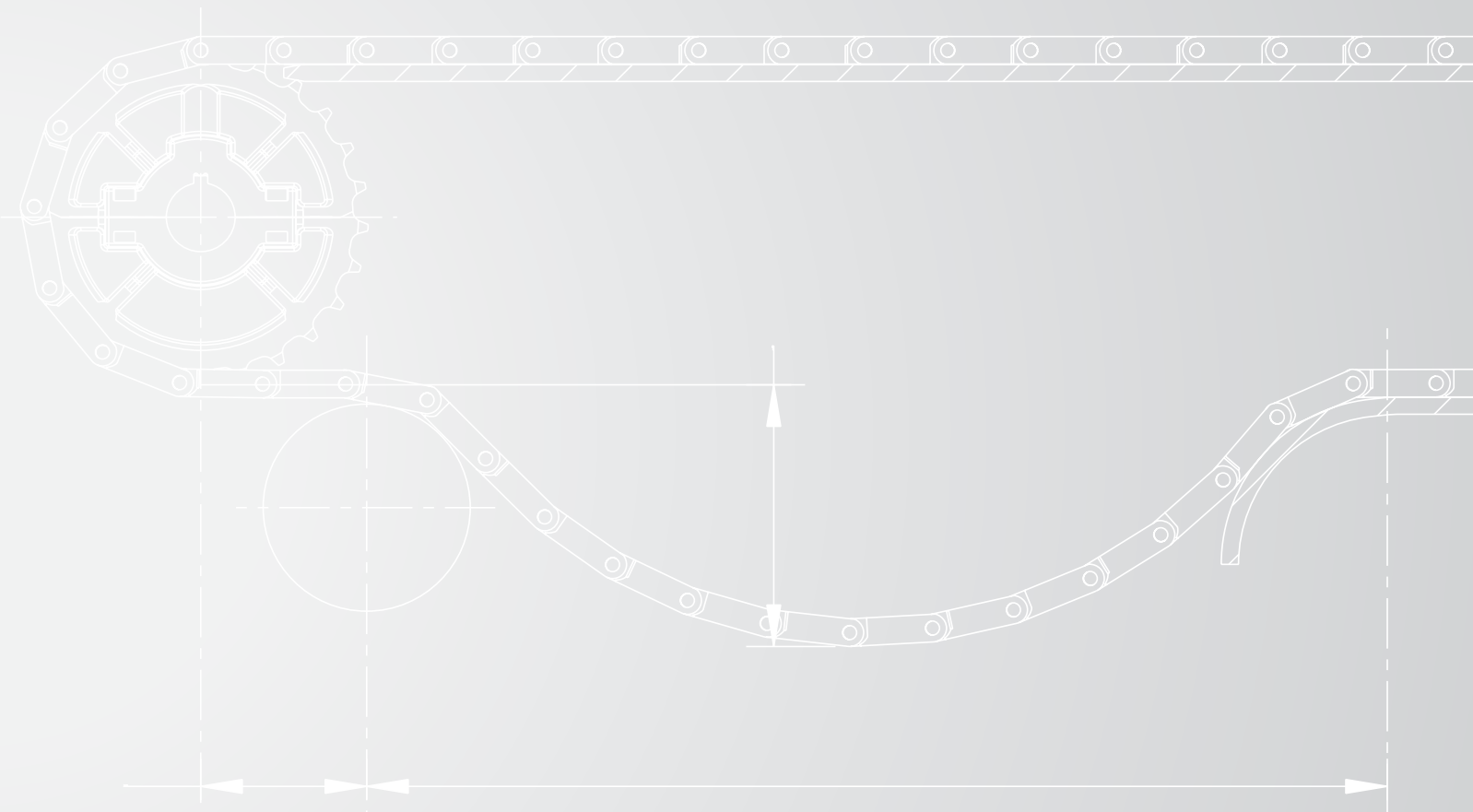

INDEX (continued)

| | |
|---|--------------|
| XIV. Catenary Sag | 44–46 |
| Purpose | 44 |
| Bi-Directional Bottom Drive Conveyors | 45 |
| Bi-Directional End Drive Conveyors | 45 |
| Uni-Directional End Drive Conveyors | 46 |
| XV. Conveyor Start Up | 47 |
| XVI. Cleaning and Lubrication Guidelines | 48–52 |
| General Cleaning Guidelines | 48–49 |
| Pasteurizers, Warmers and Coolers Cleaning Guidelines | 50 |
| General Lubrication Guidelines | 51 |
| Corrosion Resistance Guidelines | 52 |
| XVII. Normal Wear, Chain Elongation and Replacement Guidelines | 53–55 |
| General Notes | 53 |
| Various Modes of Wear | 53 |
| How to Measure Chain Pitch Elongation | 54 |
| Chain and Sprocket Replacement Guidelines | 55 |
| Wearstrip Replacement Guidelines | 55 |
| XVIII. Maintenance and Inspection Schedule | 56 |
| XIX. Trouble Shooting Guide | 57 |
| XX. Rexnord Pasteurizer Chain Analysis Capabilities | 58 |

▶ INTRODUCTION

The information contained in this manual will allow you to install, operate and maintain your Rexnord MatTop chain in a manner which will insure smooth operation and maximum life.

▶ Application Expertise/Superior Engineering Support

With over 120 years of experience, we are the industry's most knowledgeable team of conveying experts. Our chains are manufactured to perform better and last longer. Every chain stamped with the Rexnord brand has undergone extensive research and quality testing, ensuring your conveying needs will be met with the most economical, efficient and reliable means possible. Our qualified engineering staff is willing and able to assist you on all of your application needs. Rexnord will provide assistance with:

- Chain selection recommendations
- Chain pull calculations
- Product performance analysis
- Product handling tests
- Retrofit information
- Plant surveys
- Run dry surveys
- New product development

▶ Applications Throughout Industry

As expected, Rexnord's broad selection of chain is used throughout a wide variety of applications; such as food processing, beverage, unit handling and industrial applications. Whenever the industry has to move, transfer or deliver the goods, chain from Rexnord is the preferred choice.

▶ Online — At Your Fingertips

Let's face it — your time is valuable. At Rexnord, we realize the success of your business depends on up-to-date product information, superior technical support and customer service. That's why we've created www.rexnord.com. It's loaded with product information, useful tools and technical support options to help your business succeed. You can even search for a distributor in your area! Best of all, it's available 24 hours a day, seven days a week. So go ahead and log on today.

<http://www.rexnord.com>

▶ SYMBOLS

The documentation for this manual includes various icons described below:



Caution

This icon marks caution information that should be read before continuing on in this manual.



Information

This icon marks general information that should be read to further understand the specified topic.



Check Point

This icon marks check point information that expands on the subject explained.



Survey

This icon marks a survey that needs to be completed before continuing any process.

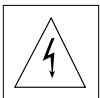

Grounding

This icon explains that grounding is crucial for all electrical equipment.

For further information about the use of the icons in this manual, please contact Rexnord Application Engineering 1.262.376.4800.

Contact Rexnord Application Engineering for more information 1.262.376.4800

SAFETY INFORMATION

PRODUCT SAFETY: Products designed and manufactured by Rexnord are capable of being used in a safe manner; but Rexnord cannot warrant their safety under all circumstances. **PURCHASER MUST INSTALL AND USE THE PRODUCTS IN SAFE AND LAWFUL MANNER IN COMPLIANCE WITH APPLICABLE HEALTH AND SAFETY REGULATIONS AND LAWS AND GENERAL STANDARDS OF REASONABLE CARE; AND IF PURCHASER FAILS TO DO SO, PURCHASER SHALL INDEMNIFY REXNORD FROM ANY LOSS, COST OR EXPENSE RESULTING DIRECTLY OR INDIRECTLY FROM SUCH FAILURE.**

SAFETY DEVICES: Products are provided with only safety devices identified herein. **IT IS THE RESPONSIBILITY OF PURCHASER TO FURNISH APPROPRIATE GUARDS FOR MACHINERY PARTS** in compliance with MSHA or OSHA Standards, as well as any other safety devices desired by Purchaser and/or required by law; and **IF PURCHASER FAILS TO DO SO, PURCHASER SHALL INDEMNIFY REXNORD FROM ANY LOSS, COST OR EXPENSE RESULTING DIRECTLY OR INDIRECTLY FROM SUCH FAILURE.**

General Safety Precautions:

- To avoid personal injury, all machinery must be turned off and locked out, prior to chain installation, inspection, maintenance and removal
- Always use safety glasses to protect eyes. Wear protective clothing, gloves and safety shoes.
- Support the chain to prevent uncontrolled movement of the chain and parts
- Maintain tools in proper condition and assure their proper use. Use of chain assembly tools is recommended when applicable
- Do not attempt to connect or disconnect chain unless chain construction is clearly known and understood
- Do not use any sections of damaged chains because they may have been overloaded and yielded



Fire Precaution:

If any flame cutting, welding, etc. is to occur in the conveyor vicinity, take adequate precautions to insure that no burning of any chain or other components occurs. If adequate protection cannot be provided, remove the chain and other plastic components from the conveyor and store in a safe location. Thermoplastic and similar materials can burn and give off toxic fumes.

DO NOT INSTALL, OPERATE OR PERFORM MAINTENANCE ON THIS PRODUCT UNTIL YOU READ AND UNDERSTAND THE INSTRUCTIONS CONTAINED IN THIS MANUAL.

▶ CHAIN MATERIALS AND CONSTRUCTION

For more detailed material information, see [FlatTop Engineering Manual \(8rxEM-en\)](#), page EM - MT - 14.

Materials vary per chain series; see Product Catalog to determine standard versus special materials.

▶ Acetal Family

▶ LF and WLF (Low-Friction)

⇒ Patented blend of acetal that provides good wear resistance and long service life due to the low coefficient of friction

▶ HP and WHP (High Performance)

⇒ Patented blend of acetal specifically formulated for dry-running conveyors due to excellent friction characteristics

▶ XLG (Low-Friction Acetal, Green)

⇒ Internally lubricated extra low-friction acetal

▶ PS (Platinum Series)

⇒ Patented blend of acetal specially formulated for high-speed conveying applications

▶ PSX (Platinum Series X)

⇒ High-speed conveying with little to no external lubrication

⇒ Long wear life with minimal dusting

▶ Specialty Plastics

▶ AS (Anti-Static)

⇒ An electrically conductive acetal formulated to reduce or eliminate nuisance static charge

⇒ **ALWAYS** contact Rexnord Application Engineering for assistance

▶ HCAS (High Capacity Anti-Static)

⇒ Reduces or eliminates nuisance static

⇒ High capacity acetal resin, requires 10% derate from acetal counterparts

▶ BIR (Black Impact-Resistant)

⇒ Specifically formulated to take constant impact

▶ ESD (Electrostatic Dissipative)

⇒ Polypropylene formulated for conveying sensitive products such as electronics and computer chips where controlling static charge or static decay is critical

⇒ **ALWAYS** contact Rexnord Application Engineering for assistance

▶ HC-ESD (High Capacity, Electrostatic Dissipative)

⇒ High capacity polypropylene formulated for conveying sensitive products such as electronics and computer chips where controlling static charge or static decay is critical

⇒ Requires 10% derate from polypropylene counterparts

⇒ **ALWAYS** contact Rexnord Application Engineering for assistance

▶ FTR (Black, Fryer Temperature-Resistant)

⇒ Formulated to be used in oven/fryer discharge conveyor applications such as snack chips

▶ GTC (Grey Tough Composite)

⇒ High-strength, impact-modified composite

⇒ High impact resistance, low strength

▶ USP (Ultra-Stabilized Polypropylene, Dark Green)

⇒ Superior resistance to chemicals used in pasteurizers, warmers and coolers

⇒ Remains stronger and more flexible than standard polypropylene

▶ BWR (Black Wear-Resistant)

⇒ BWR may extend chain life up to 5 times in comparison to other plastic materials in applications such as conveying rough machined parts

▶ WX/BWX (Abrasion-Resistant)

⇒ A nylon material formulated to be used in abrasive applications where chain is subjected to abrasives such as glass, sand and dirt

▶ DKA

⇒ Advanced composite resin

⇒ Good abrasion resistance

⇒ Low coefficients of friction

⇒ Can be used in both wet and dry environments

▶ CHAIN MATERIALS AND CONSTRUCTION

▶ P (Chemical-Resistant)

- ⇒ A polyester formulated to reduce or eliminate material degradation in applications where chemicals such as chlorine and phosphorous are present in moderate concentrations

▶ CR (Extreme Chemical-Resistant)

- ⇒ Fluorinated polymer that is chemically resistant to high concentrations of oxidizing agents, acids and bases

▶ DUV, BUV, YUV, HUV and LUV (Ultraviolet-Resistant)

- ⇒ Specially formulated acetal
- ⇒ Used for outdoor applications with direct exposure to the sun or UV radiation
- ⇒ DUV, BUV, YUV, RUV — Acetal
LUV — Polyethylene

▶ MR (Melt-Resistant)

- ⇒ A nylon material with a high melting point used to prevent hot objects (product temperature up to 375°F [190°C]) from melting the surface of the chain

▶ HTX (Extreme High Temperature)

- ⇒ Specially formulated for heat tunnel applications
- ⇒ Designed to eliminate brittle oxidation of chain
- ⇒ Suitable for up to 500°F (260°C) heat tunnels

▶ FR (Flame-Retardant)

- ⇒ Flame-retardant polyester that meets the requirements of UL Standard 94 V-0 rated combustion

▶ FRPLUS (Flame Retardant Low Friction)

- ⇒ Developed for metal container manufacturing
- ⇒ Provides high wear resistance
- ⇒ Will not support combustion
- ⇒ Low friction can run dry

▶ HS (Heat-Stabilized)

- ⇒ Nylon resin designed for environments that contain hot water spray (rinsers, sterilizers and pasteurizers applications)

▶ WSM, BSM, BRSM, BYSM, RSM, SRMB, SYMB, YSM and SMB (Cut-Resistant)

- ⇒ Tough acetal material formulated for abrasive and impact loading applications
- ⇒ Cut-resistant material commonly used in the meat processing industry on cutting, boning and trimming lines
- ⇒ Available in many colors

▶ HT, WHT, KHT, BHT, HTB and RHT (High-Temperature)

- ⇒ Polypropylene formulated for high-temperature and general applications in both wet and dry conditions
- ⇒ Excellent chemical resistance

▶ TC (Tough Composite)

- ⇒ Specially formulated alloy, high strength, toughened composite material
- ⇒ Excellent for high-speed case incline and decline conveyors
- ⇒ Excellent impact and chemical resistance

▶ UHS (Ultra High Strength)

- ⇒ Patented polypropylene composite that allows for increased load-carrying capacity and reduced stretch at elevated temperatures
- ⇒ Ideal for heavy-duty pasteurizer, sterilizer and cooler applications

▶ WLT and BLT (Low-Temperature)

- ⇒ Polyethylene formulated to retain toughness, impact strength and ductility in both dry and wet conditions
- ⇒ Good chemical resistance
- ⇒ Available in white and blue



Since materials vary in strength, refer to the Product Catalog for specific chain/material strengths when changing out materials.

▶ CHAIN MATERIALS AND CONSTRUCTION

▶ GLD and RLD (Low-Temperature Detectable) ***

- ⇒ A patented blend of polyethylene and non-ferrous metal particulate
- ⇒ Allows for detection as it passes through a metal detector in dry and frozen food applications
- ⇒ Available in gray and red

▶ THD (High-Temperature Detectable) ***

- ⇒ A patented blend of polypropylene and non-ferrous metal particulate
- ⇒ Allows for detection as it passes through a metal detector in dry and frozen food applications

*** These materials meet the end-test requirements as specified by FDA 21 CFR 177.1520 (c), the FDA requirement for polyolefin materials intended for food contact. All components of these materials are either compliant for food contact a listed by the FDA or regulated by the EPA.

i Standard pin materials for MatTop Chains include:

- Polypropylene
- Polyethylene
- Acetal
- Polyester (PBT)
- Stainless steel available (typically for severely abrasive environments)

i Not all materials are available in all chains. Contact Rexnord Application Engineering for further assistance.

CHAIN MATERIALS AND CONSTRUCTION

Chain Surface Styles



Solid Top

- ⇒ Not necessarily 0% open area
- ⇒ General use

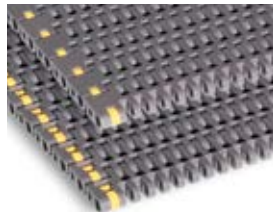

Perforated Top

- ⇒ Used where air or water flow is required
- ⇒ Open area from 6 to 30%



Open Area

- ⇒ Used where the maximum amount of air or water flow is required
- ⇒ Open area larger than 30%



Raised Rib

- ⇒ Used where very smooth head transfers are required
- ⇒ Utilized with transfer combs



Textured Top

- ⇒ Used to reduce products from sticking to the chain



LBP

- ⇒ Low backline pressure used to minimize backline pressure between products



Transverse LBP

- ⇒ Low backline pressure used to transfer products at 90°



Rubbertop/Supergrip

- ⇒ High friction rubber surface used on incline/decline conveyors, brake belts and metering belts



Safety Top

- ⇒ Provides a slip-resistant surface where people walk on the chain

▶ CHAIN MATERIALS AND CONSTRUCTION

▶ Assembled to Width (ATW) vs. Molded to Width (MTW)

▶ Assembled to Width

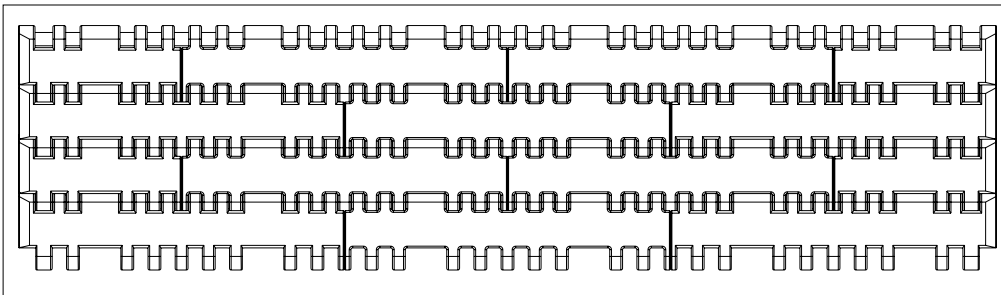

- ⇒ Width determined by customer order
 - ⇒ Rexnord stocks families of modules
 - ⇒ Refer to the **Chain Width Table** in the MatTop section of the [Product Catalog \(8rxCAT-en\)](#) for specific widths
 - ⇒ Bricked construction
 - ⇒ Assembled to customer order
- i** Standard width chains are recommended. For more width increments, “Cut to width” chains are also available (refer to the **Chain Width Table** in the MatTop section of the [Product Catalog \(8rxCAT-en\)](#))

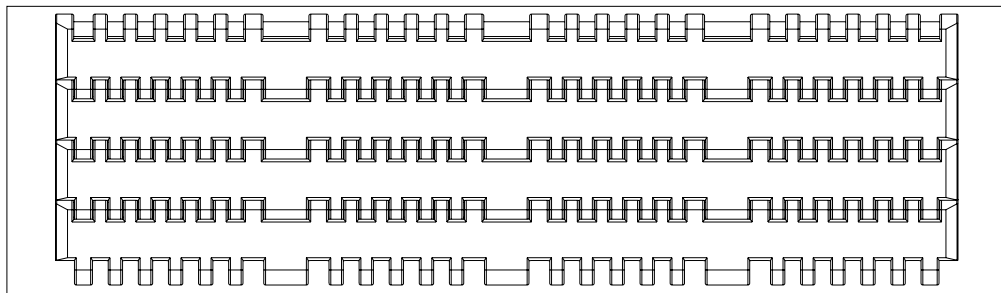

▶ Molded to Width

- ⇒ Available in standard MatTop chain widths (i.e. 3-1/4 in, 84mm, 4 in, 4-1/2 in, 6 in, 7-1/2 in, 12 in, 15 in)
- ⇒ Refer to the **Chain Width Table** in the MatTop section of the [Product Catalog \(8rxCAT-en\)](#) for specific widths
- ⇒ Available with or without Positrack tracking guides in some chain styles
- ⇒ Stocked in 10 ft lengths

▶ CHAIN MATERIALS AND CONSTRUCTION

▶ Pin Retention Systems/Chain Disassembly and Assembly

▶ Soldered Head Pin Retention Chains

⇒ Chains included: Series 4700, 6930

4705 chain shown



Tools needed — A 3/16" or 1/4" diameter drive pin punch, hammer and soldering iron with proper tip (see table below)

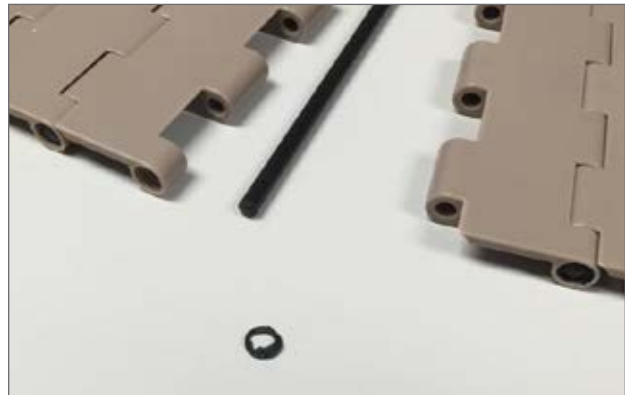

Disassembly — Using the pin punch, hammer the pin through the link until the head breaks off and the opposite end can be gripped and pulled through the remaining links

Assembly — Replace all pins that were removed with new pins. Cut the pin so that it protrudes by approximately the diameter of the pin so a head can be formed. Use a soldering iron to form a pin head so the head is recessed in the end of the link.

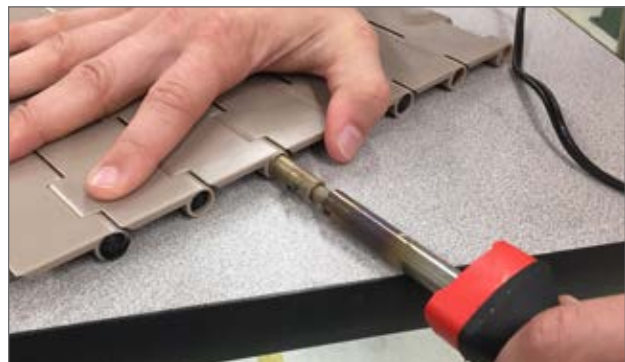

| MatTop Pin Soldering Tips and Soldering Iron | | |
|--|-----------------------------------|--------------|
| Part Number | Description | Chain Series |
| 114-2047-1 | Solder Tip for a 3/16" MatTop Pin | 5930, 6930 |
| 114-2128-1 | Solder Tip for a 1/4" MatTop Pin | 4700, 5960 |
| 114-2437-1 | Solder Tip for a 5/16" MatTop Pin | 5990 |
| 10101871 | Soldering Iron | All |

Contact Rexnord Application Engineering for more information 1.262.376.4800

▶ CHAIN MATERIALS AND CONSTRUCTION

▶ Pin Retention Systems/Chain Disassembly and Assembly

▶ Plug-Plug Pin Retention Chains

⇒ Chains included: Series 1000, 1500, 5700, 5998, 5998HD, 6080, 7748, 7960, 8503

FT1000 chain shown

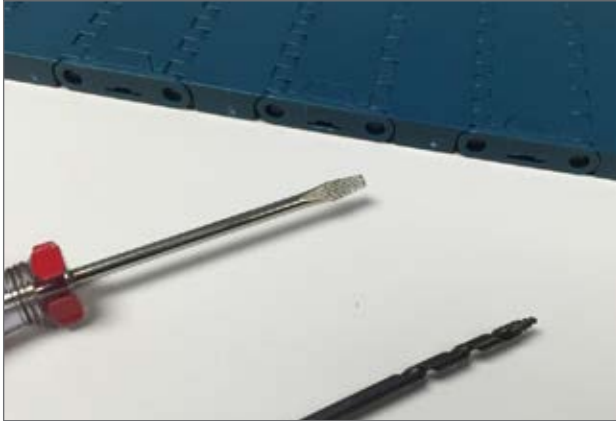

Tools needed — Small flat blade screwdriver and pin puller

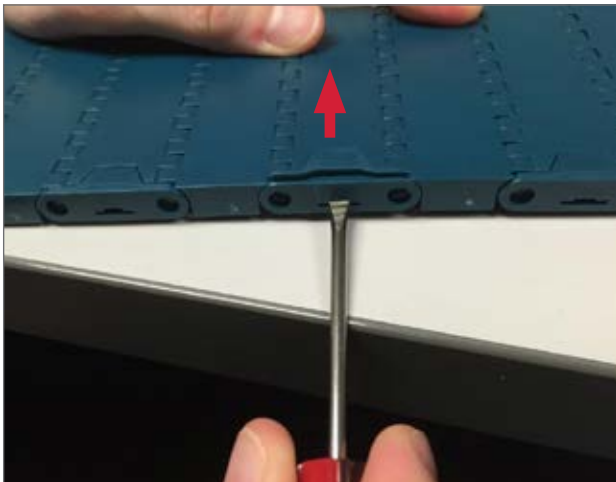

Disassembly — Insert the screwdriver into the access slot and push up until the clip can be pulled out

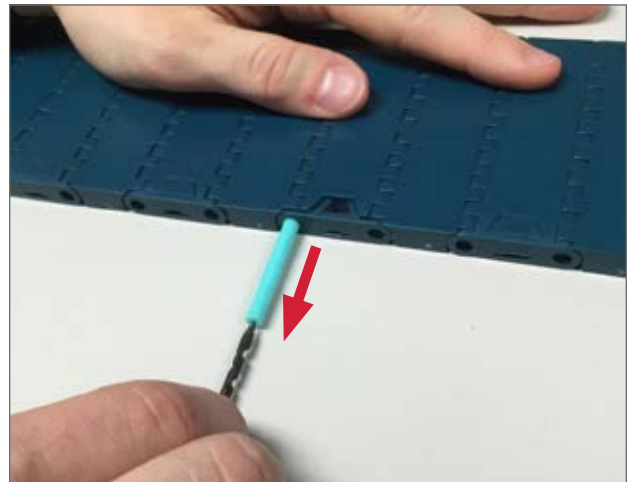

Disassembly — Pull out pins to disconnect chain
Note: Series 1000 chains require two pitches at a time to be removed or added



Assembly — Replace all pins and snap the clip back into position

Contact Rexnord Application Engineering for more information 1.262.376.4800

▶ CHAIN MATERIALS AND CONSTRUCTION

▶ Pin Retention Systems/Chain Disassembly and Assembly

▶ Plug-Plug Pin Retention Chains

⇒ Chains included: Series 1000, 1500, 5700, 5998, 5998HD, 6080, 7748, 7960, 8503

1505 chain shown

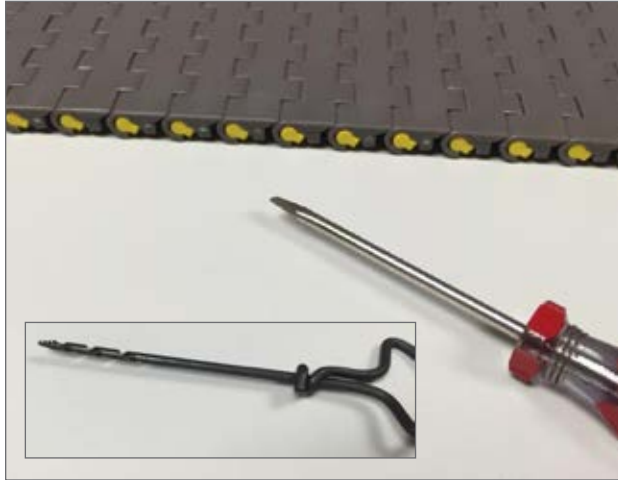

Tools needed — Small flat blade screwdriver and pin puller

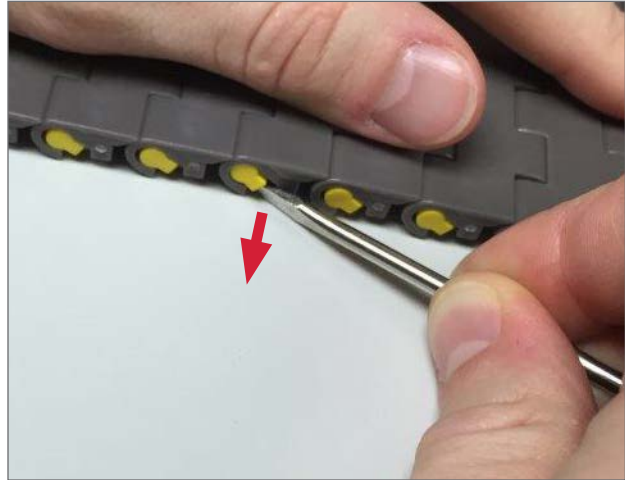

Disassembly — Insert the screwdriver under the end of the plug to remove it

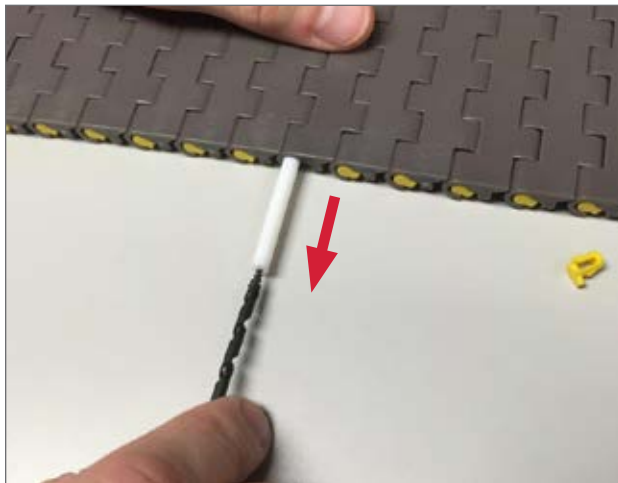

Disassembly — Use pin puller to remove pin

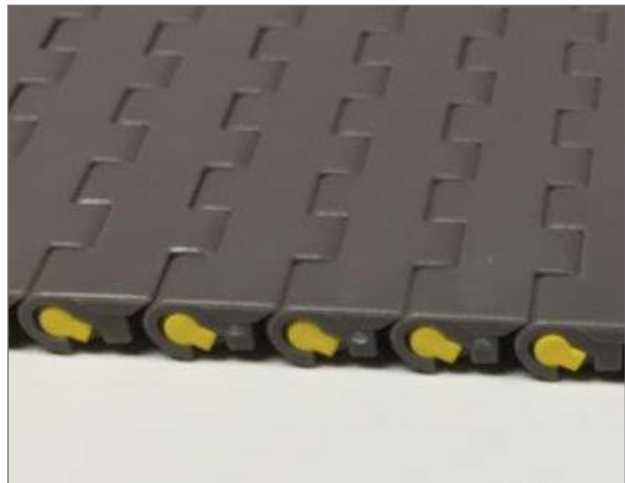

Assembly — Replace the pin and snap the plug back into position

▶ CHAIN MATERIALS AND CONSTRUCTION

▶ Pin Retention Systems/Chain Disassembly and Assembly

▶ Plug-Plug Pin Retention Chains

⇒ Chains included: Series 1000, 1500, 5700, 5998, 5998HD, 6080, 7748, 7960, 8503

5705 chain shown

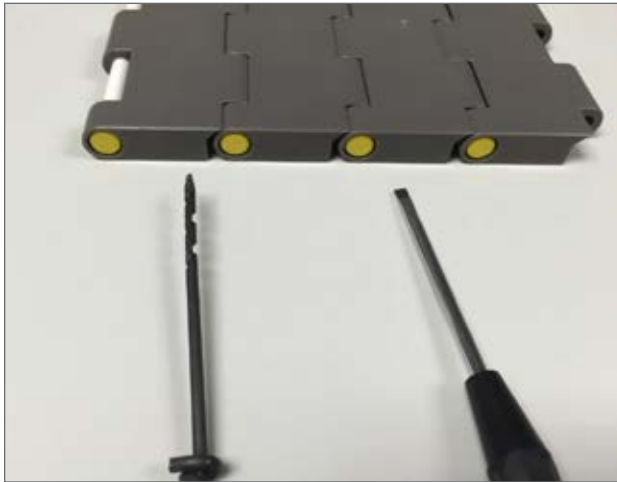

Tools needed — Small flat blade screwdriver and pin puller

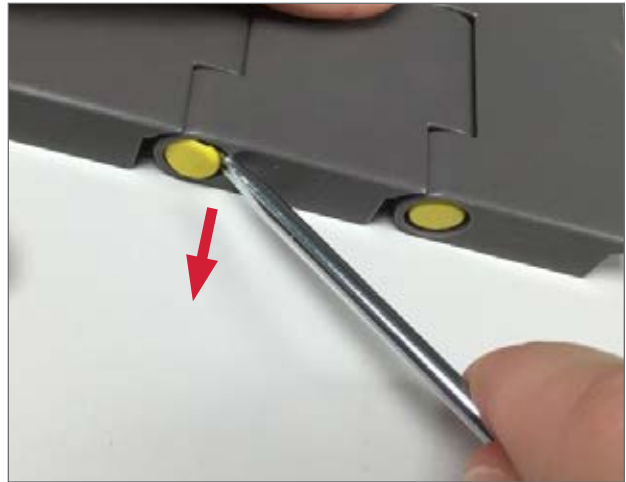

Disassembly — Insert the screwdriver under the plug to remove it

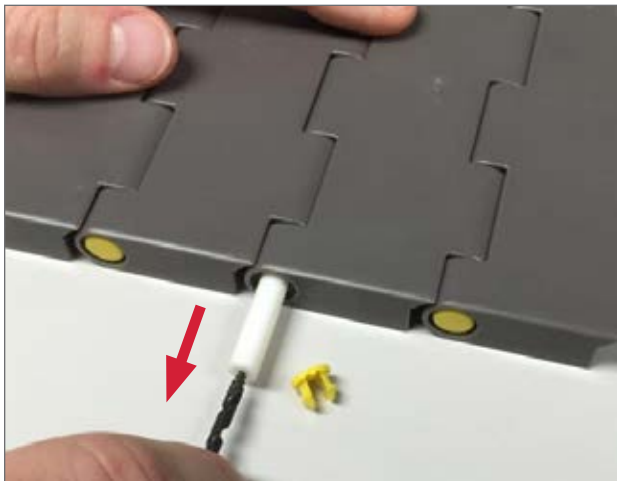

Disassembly — Use pin puller to remove pin

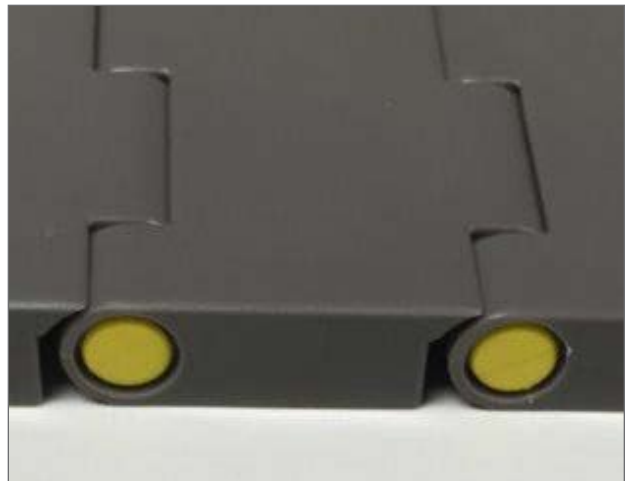

Assembly — Replace the pin and snap the plug back into position

▶ CHAIN MATERIALS AND CONSTRUCTION

▶ Pin Retention Systems/Chain Disassembly and Assembly

▶ Plug-Plug Pin Retention Chains

⇒ Chains included: Series 1000, 1500, 5700, 5998, 5998HD, 6080, 7748, 7960, 8503

5998 chain shown



Tools needed — 1/8" flat blade screwdriver and pin puller

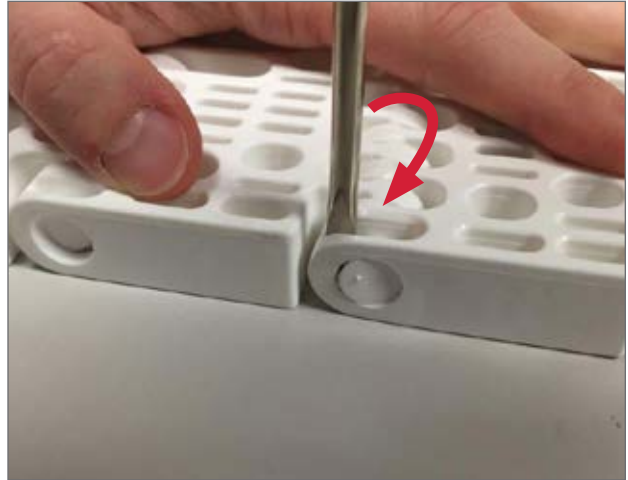

Disassembly — Insert the screwdriver behind the plug and rotate screwdriver to remove the plug

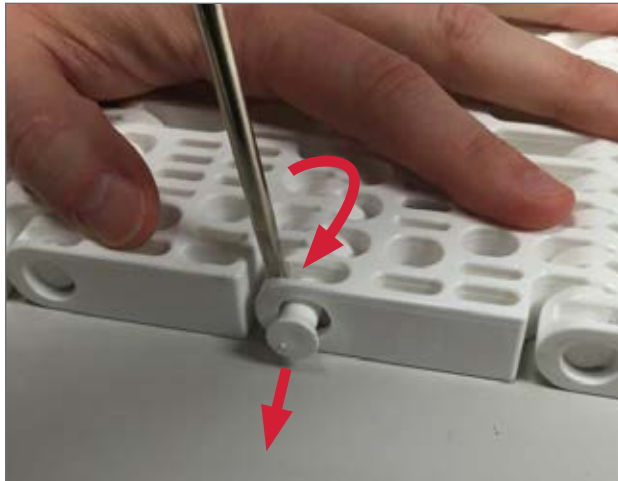

Disassembly — The plug can now be removed



Disassembly — Use pin puller to remove pin



Assembly — Replace the pin and snap the plug back into position

Contact Rexnord Application Engineering for more information 1.262.376.4800

▶ CHAIN MATERIALS AND CONSTRUCTION

▶ Pin Retention Systems/Chain Disassembly and Assembly

▶ Plug-Plug Pin Retention Chains

⇒ Chains included: Series 1000, 1500, 5700, 5998, 5998HD, 6080, 7748, 7960, 8503

5998HD chain shown



Tools needed — A 3/16" or 1/4" diameter drive pin punch, hammer and pin puller

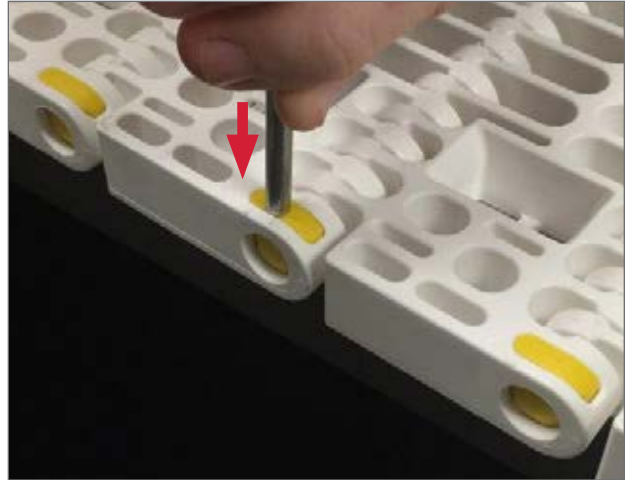

Disassembly — From the bottom side of the chain, drive the plug out using the punch and hammer

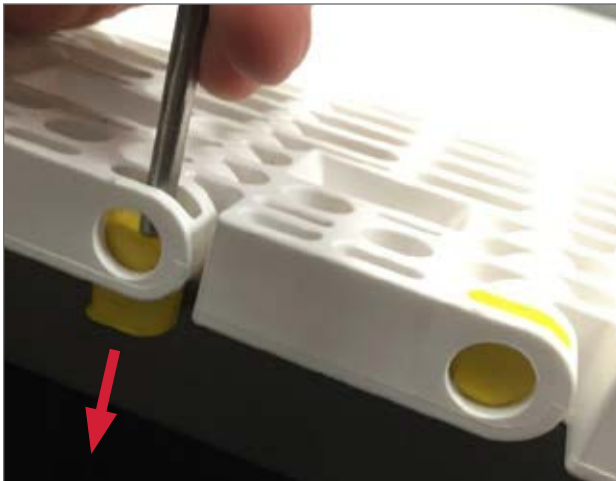

Disassembly — The plug can now be removed

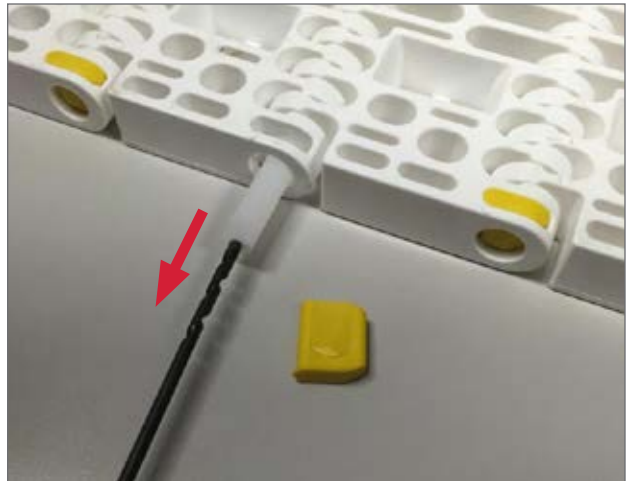

Disassembly — Use pin puller to remove pin



Assembly — Replace the pin and snap the plug back into position from the bottom of the chain

Contact Rexnord Application Engineering for more information 1.262.376.4800

▶ CHAIN MATERIALS AND CONSTRUCTION

▶ Pin Retention Systems/Chain Disassembly and Assembly

▶ Plug-Plug Pin Retention Chains

⇒ Chains included: Series 1000, 1500, 5700, 5998, 5998HD, 6080, 7748, 7960, 8503

7960NT chain shown

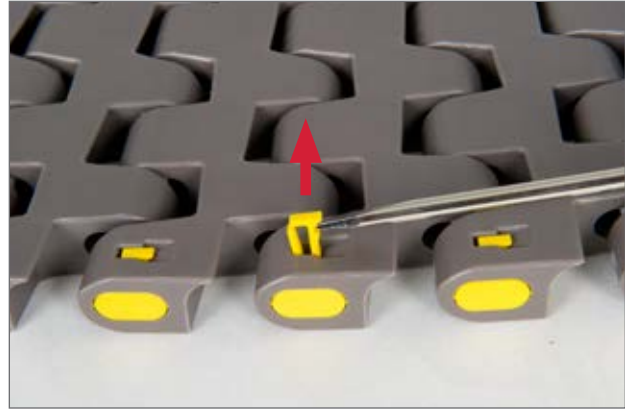
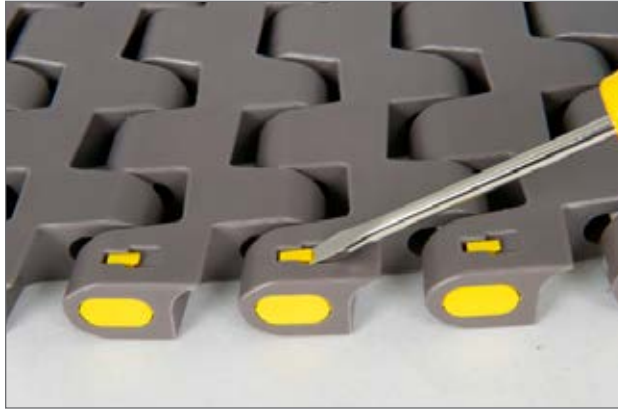

Disassembly — Using a narrow flat blade screwdriver, remove retention stake by lifting up on the backside of the tab

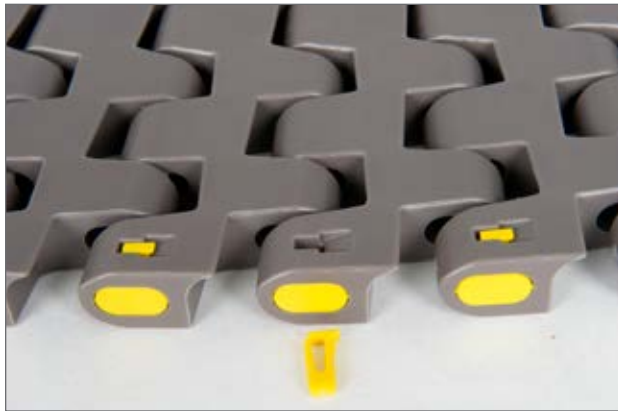

Disassembly — With retention stake removed, push wear block out of chain link from backside as shown

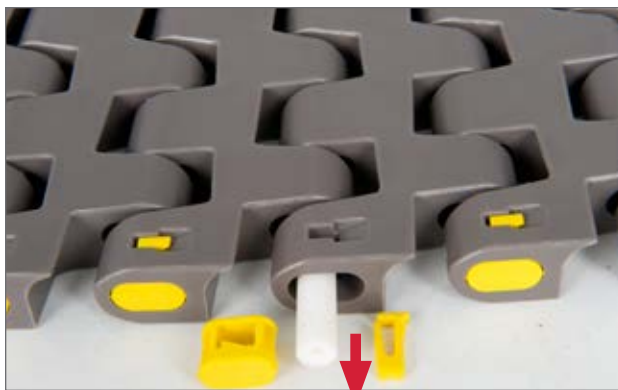

Disassembly — With both the retention stake and wear block removed, pull or push the pin out of chain assembly from either side

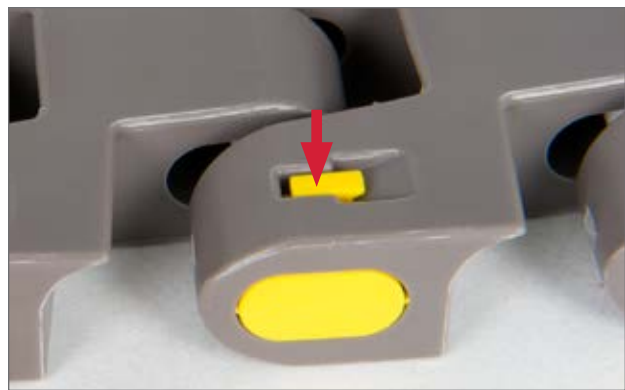

Assembly — Replace the pin, insert the wear block and snap the retention stake back down into position

Contact Rexnord Application Engineering for more information 1.262.376.4800

▶ CHAIN MATERIALS AND CONSTRUCTION

▶ Pin Retention Systems/Chain Disassembly and Assembly

▶ Plug-Blind Pin Retention Chains

⇒ Chains included: Series 1625, 5930, 5960, 5990, 7526

7526 chain shown

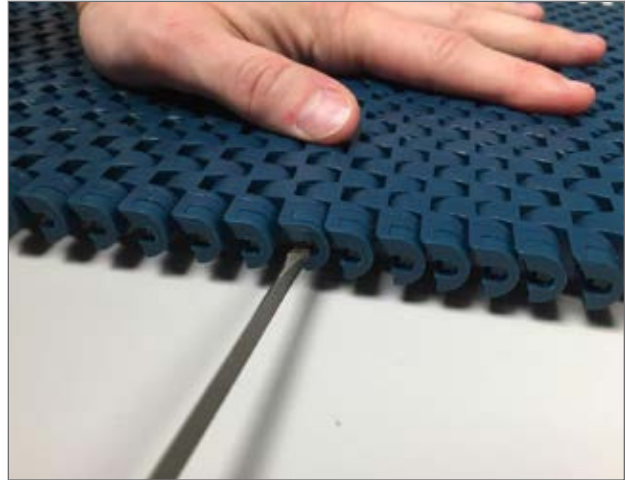
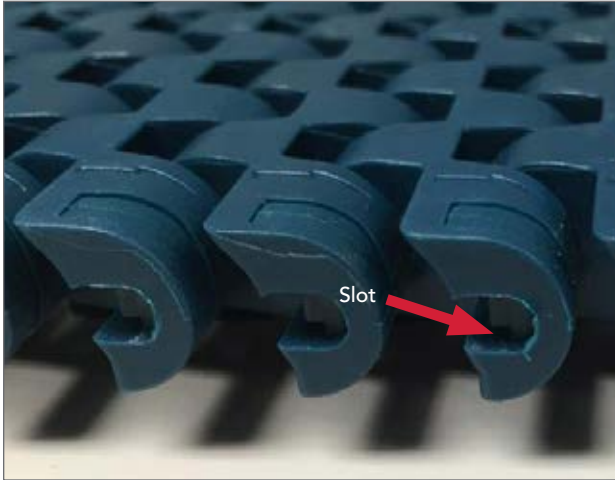

Disassembly — Insert a narrow flat blade screwdriver into the small slot in the plug

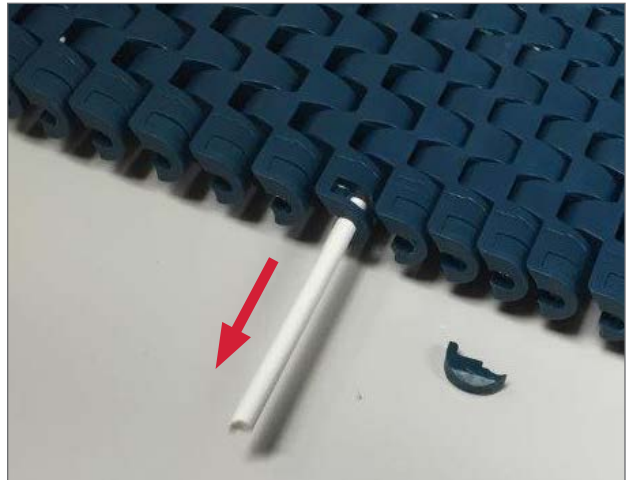
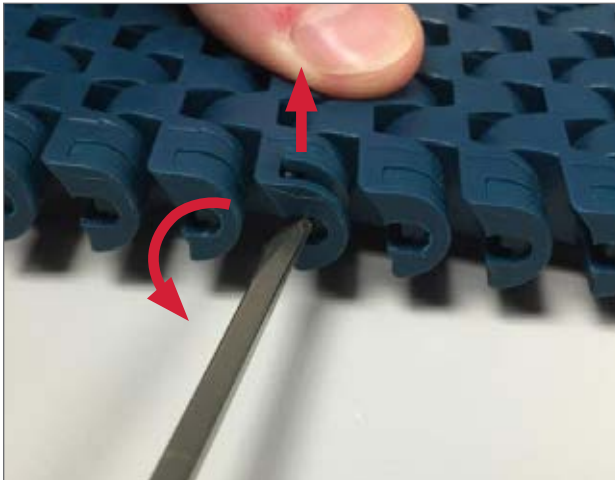

Disassembly — Rotate screwdriver so the plug can be lifted out. The pin can then be removed.

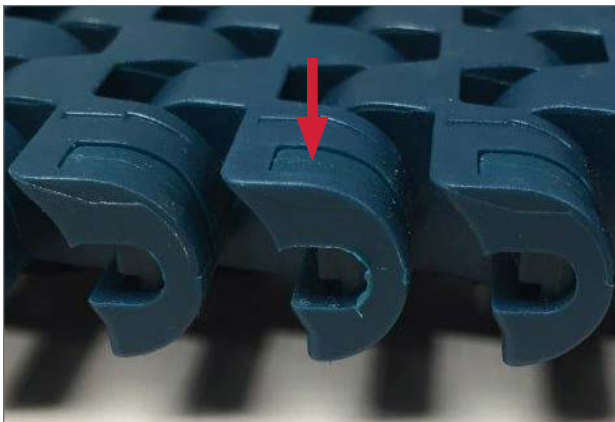

Assembly — Replace the pin, snap the plug back down into position

Contact Rexnord Application Engineering for more information 1.262.376.4800

▶ CHAIN MATERIALS AND CONSTRUCTION

▶ Pin Retention Systems/Chain Disassembly and Assembly

▶ Plug-Blind Pin Retention Chains

⇒ Chains included: Series 1625, 5930, 5960, 5990, 7526

1625B-TAB chain shown

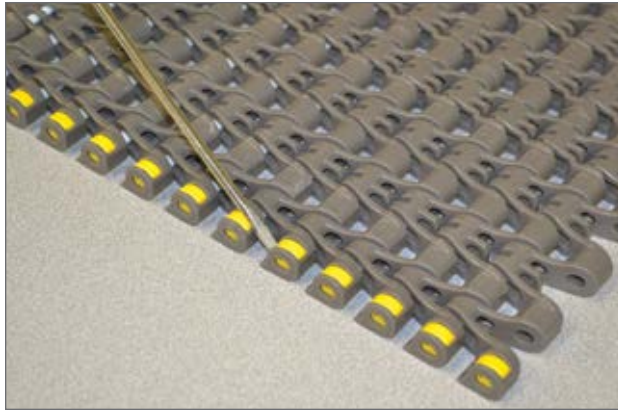

Disassembly — From the bottom side of chain, Insert a small flat screwdriver under the edge of the retention plug and lift out as shown

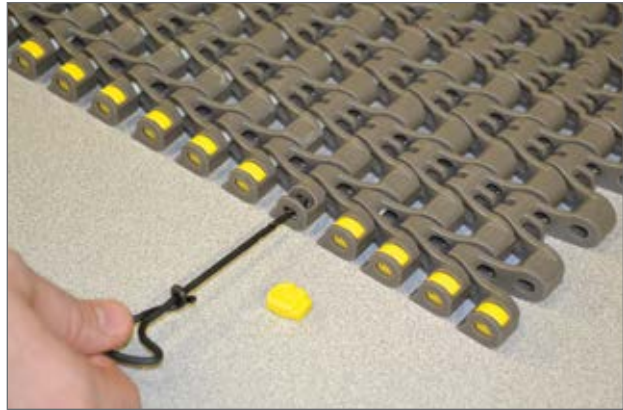

Disassembly — Use the pin puller to thread into the end of the plastic pin and pull the plastic pin out of the chain as shown

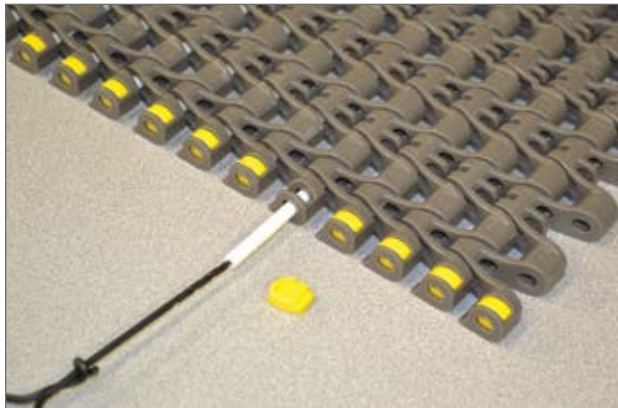

Disassembly — After the removal of the plastic pin, the chain can be separated

Assembly — Replace the pin, snap the plug back into position

▶ CHAIN MATERIALS AND CONSTRUCTION

▶ Pin Retention Systems/Chain Disassembly and Assembly

▶ TwistLock Pin Retention Chains

⇒ Chains included: Series 1265, 1285, 3000, 3100, 3180, 6990, 6995H, 6999H, 7700, 7956, 8500, 9600

7706 chain shown



Chain with correctly installed TwistLock plug

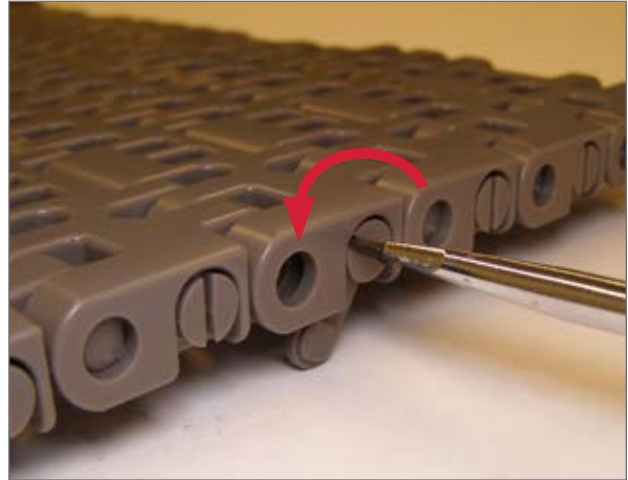

Disassembly — Using a flat blade screwdriver, rotate TwistLock plug 90 degrees

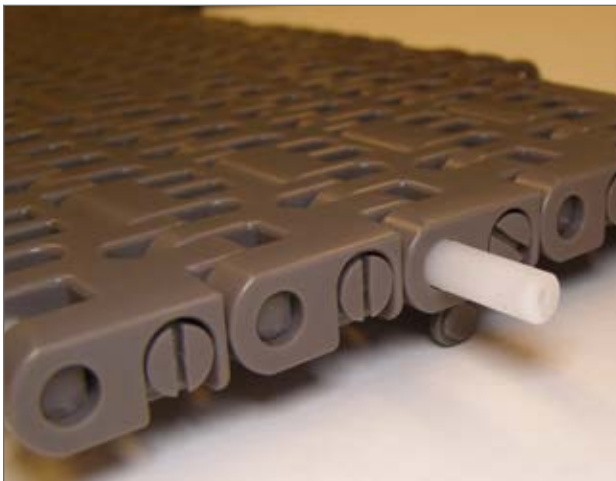

Disassembly — Use a pin puller to pull out pin



Assembly — Reinsert pin and rotate TwistLock plug back to full closed position

▶ CHAIN MATERIALS AND CONSTRUCTION

▶ Pin Retention Systems/Chain Disassembly and Assembly

▶ TwistLock Pin Retention Chains

⇒ Chains included: Series 1265, 1285, 3000, 3100, 3180, 6990, 6995H, 6999H, 7700, 7956, 8500, 9600

7956B/GT/NT/TAB



7956B



7956GT



7956NT



7956TAB

Disassembly (7956B chain shown):



Rotate TwistLock



Pull out pin



Pull out TwistLock plug



Attachment can be removed from bottom of chain



Assembly:

Repeat above steps in reverse order

Contact Rexnord Application Engineering for more information 1.262.376.4800

▶ CHAIN MATERIALS AND CONSTRUCTION

▶ Pin Retention Systems/Chain Disassembly and Assembly

▶ TwistLock Pin Retention Chains

⇒ Chains included: Series 1265, 1285, 3000, 3100, 3180, 6990, 6995H, 6999H, 7700, 7956, 8500, 9600

Disassembly of 6995H/6999H



Insert flat screwdriver



Twist screwdriver 90 degrees clockwise to open pin retention



Open pin retention and pull out pin

Note: The opposite side can be opened and pins can be pushed out



Assembly — Reinsert pin and rotate pin retention to full closed position until you can feel and hear 'click'

▶ CHAIN MATERIALS AND CONSTRUCTION

▶ Pin Retention Systems/Chain Disassembly and Assembly

▶ Offset Pin Hole Retention Chains

⇒ Chains included: Series 1010, 1255, 1275, 1553, 5998 (also listed under Plug-Plug)

1015 chain shown



Chain with correctly installed pins

Note: The 1010 series chain is a totally plugless design

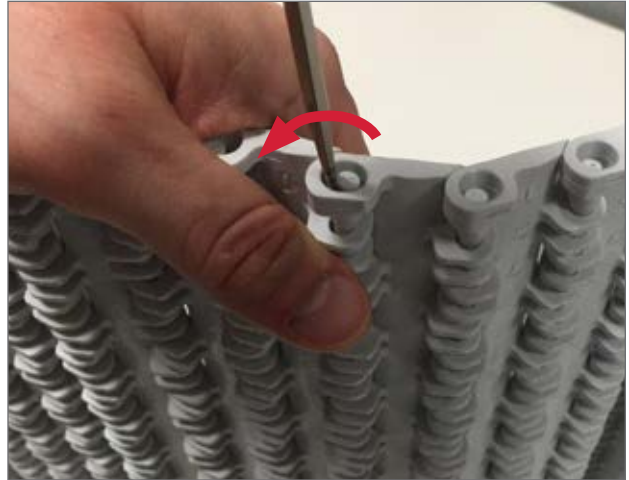

Disassembly — Insert a narrow flat blade screwdriver behind the head end of the pin, and pry the pin over and up



Disassembly — The pin can now be pulled out

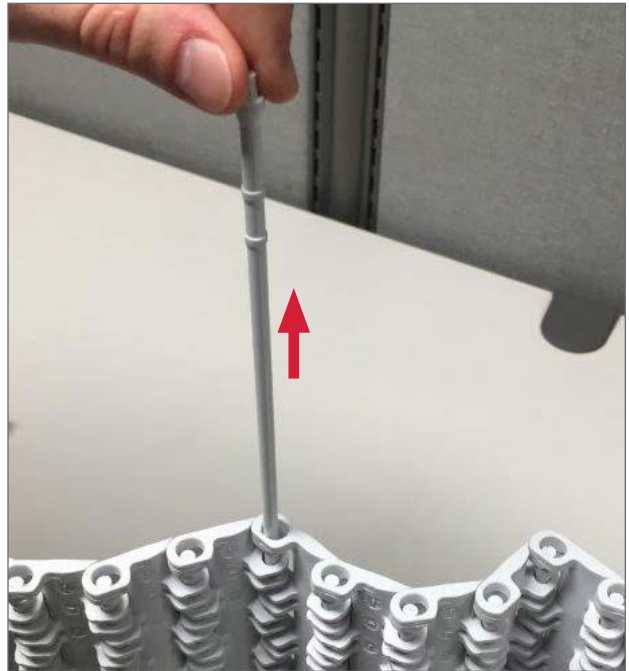

Assembly — Reinsert pin

Contact Rexnord Application Engineering for more information 1.262.376.4800

▶ CHAIN MATERIALS AND CONSTRUCTION

▶ Pin Retention Systems/Chain Disassembly and Assembly

▶ Offset Pin Hole Retention Chains

⇒ Chains included: Series 1010, 1255, 1275, 1553, 5998 (also listed under Plug-Plug)

1553 chain shown



Chain with correctly installed pins

Note: The 1553 chain is a totally plugless design



Disassembly — Insert a pin puller into end of pin from either side of chain

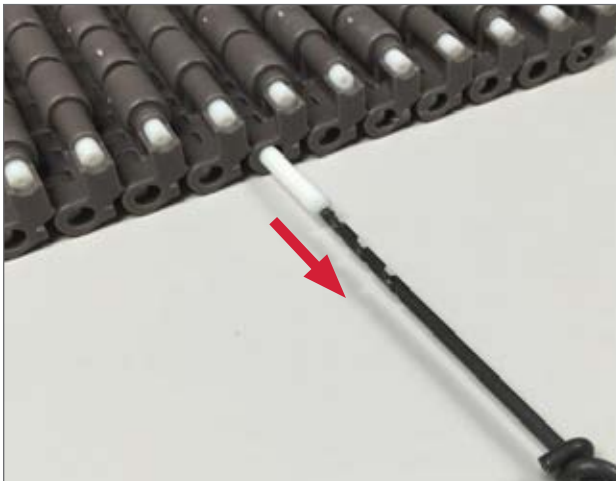

Disassembly — While shifting the pin over, pull it out

Note: The pin can also be pushed through and pulled out from the opposite side



Assembly — Reinsert pin

▶ CHAIN MATERIALS AND CONSTRUCTION

▶ Pin Retention Systems/Chain Disassembly and Assembly

▶ Integrated Locking System Retention Chains

⇒ Chains included: Series 2010

2015 chain shown

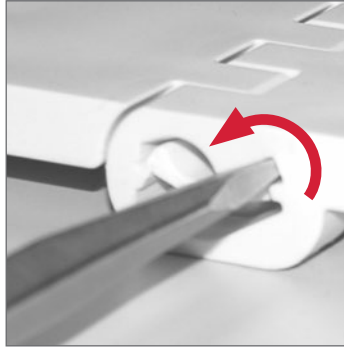

Disassembly — Using a flat blade screwdriver, rotate tab until it “clicks” to the open position

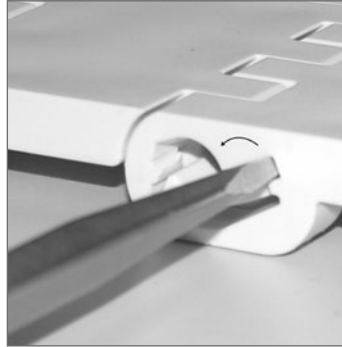

Disassembly — Tab shown in open position

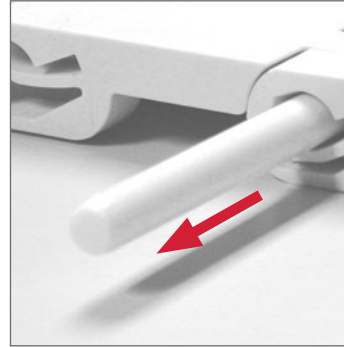

Disassembly — Pull or push out pin

Assembly — Insert pin, place screwdriver *under* the tab and rotate back to the closed position

▶ CHAIN MATERIALS AND CONSTRUCTION

▶ Pin Retention Systems/Chain Disassembly and Assembly

▶ Riveted Retention Chains

⇒ Chains included: Series 9200 Fortrex

9217 chain shown



Pin retention clips are riveted to the side of the chain

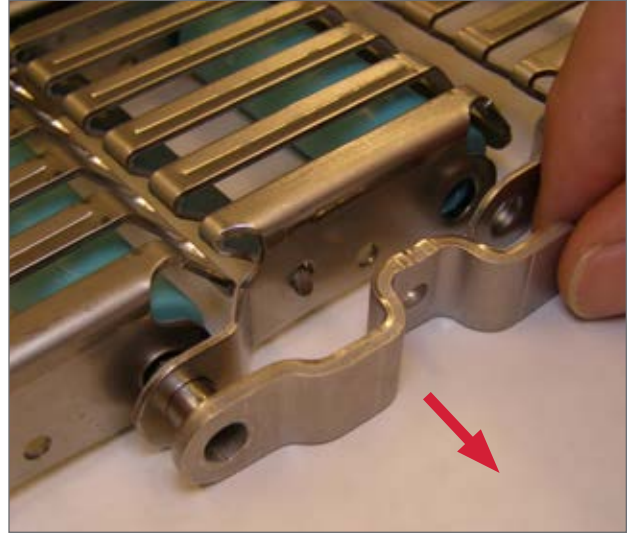

Disassembly — Drill out rivet and remove pin retention clip. Push out pin while a helper on the opposite side pulls pin.



Chain without pin retention clip

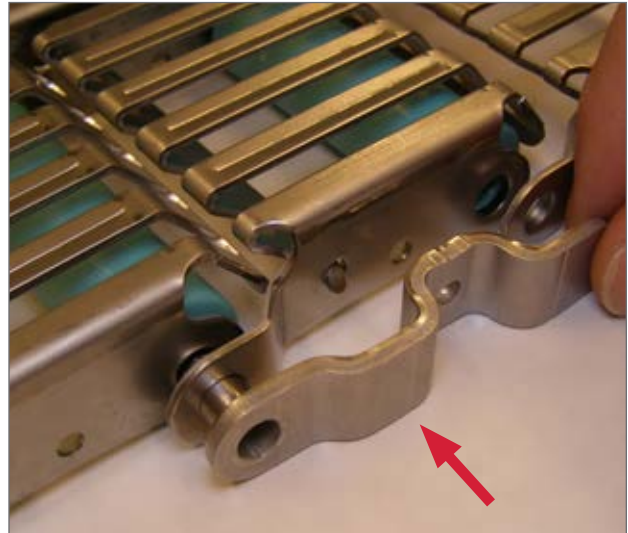

Assembly — After pin is inserted, replace pin retention clip. Pin retention clip should slide over the pin and be pop-riveted in place. Make sure stainless steel rivets are used and pin retention clips are tightly fitted to the module.

▶ CHAIN MATERIALS AND CONSTRUCTION



Chain with correctly installed pin retention

- ✓ The 9200 chain uses a special stainless steel clip that is pop-riveted to the chain on both sides using a hand or powered pop rivet gun as shown below. The pins can be accessed from either side of the chain.



Stainless steel rivets 0.1575 in. (4.0 mm) must be used (Part 820.00.09)



9200 chain rivet tool, clip and stainless steel rivet

▶ PROPER STORAGE AND HANDLING OF MATTOP CHAIN

▶ Storage

- ⇒ Always store chain out of the elements, indoors in a clean, dry environment
- ⇒ Keep chain stored on a flat surface in their original boxes until ready for use
- ⇒ Do not stack boxes too high
- ⇒ Never store chain in direct sunlight
- ⇒ Rotate stock on a first in/first out basis, using oldest chain first

▶ Handling

- ⇒ Heavy protective gloves are recommended
- ⇒ Carry chain in its rolled up form
- ⇒ Do not carry chain in the back-flexed condition as chain can be damaged and pinch points can occur

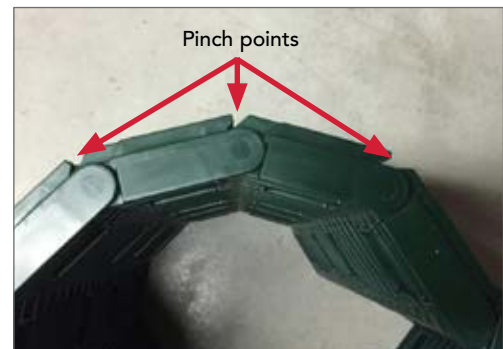
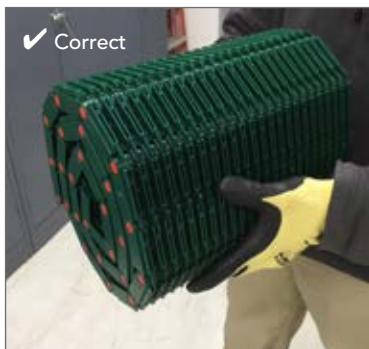

- ⇒ All Rexnord MatTop chains used in tunnel equipment (i.e. pasteurizers, warmers, etc.) are delivered in wooden crates. The chains are packaged in layers within the crates in 3 ft. (1 m) wide sections. The wood crates can be opened on the top and side so that chain can be pulled out easily, layer by layer.

- ⇒ Be careful when handling MatTop shipping crates and chain sections due to heavy weight. Wide crates & chain sections must be supported in the middle to prevent bending and/or breakage.
- ⇒ Three people are required when carrying wide heavy rolls, or use a forklift with the forks spread far apart as possible

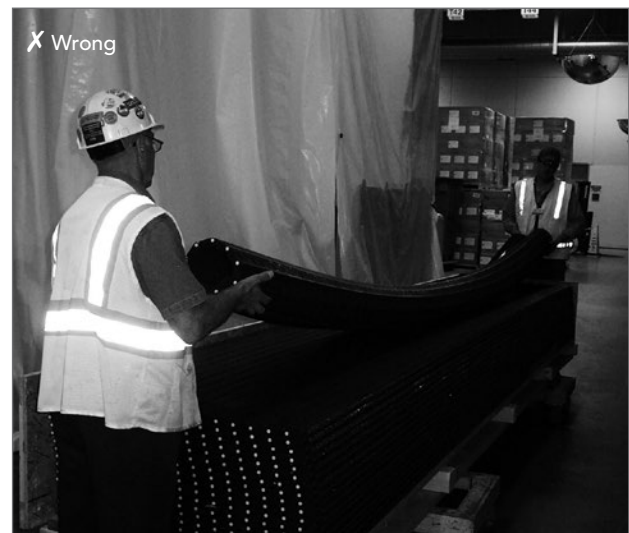

▶ SHAFT PARALLELISM

▶ Adjustment of Shafts

- ⇒ Drive and idler shafts must be perfectly level and parallel with each other in order to ensure proper chain tracking
- ⇒ This is especially important on long, wide tunnel machines (pasteurizers, warmers, coolers, etc)

- ⇒ Badly aligned shafts can cause overloading on one side of the chain, and pins to work their way out
- ⇒ The drawing below shows the dimensions to check to ensure the shafts are adjusted correctly

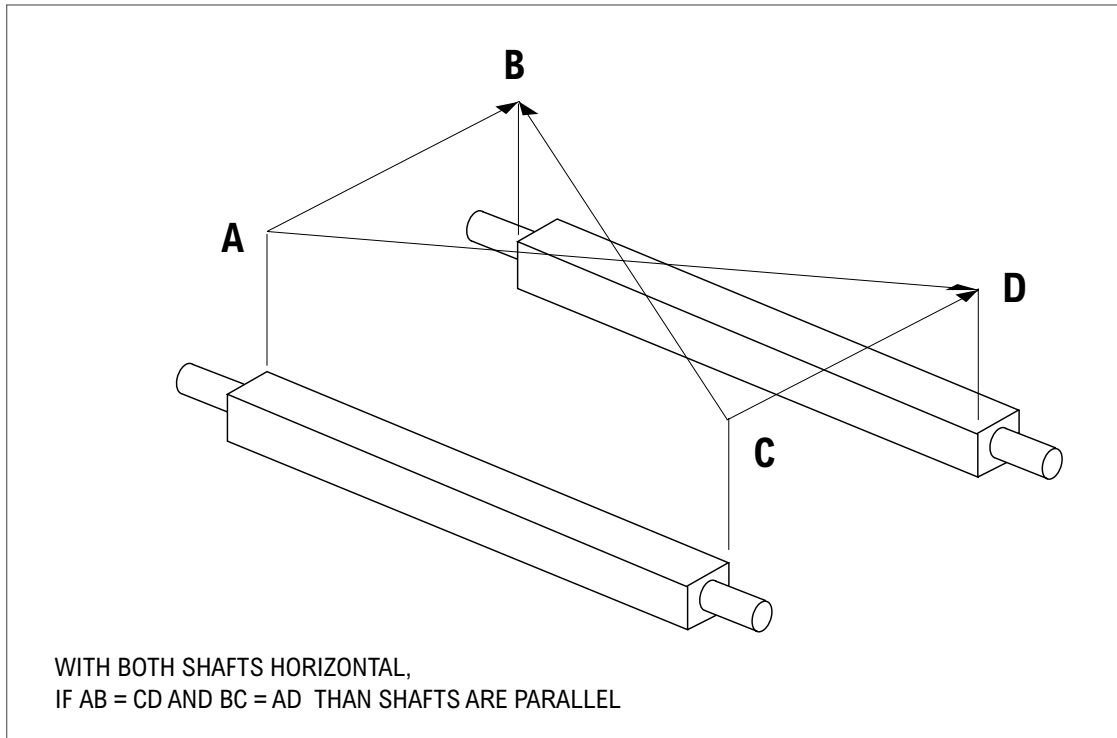

WEARSTRIPS

Patterns

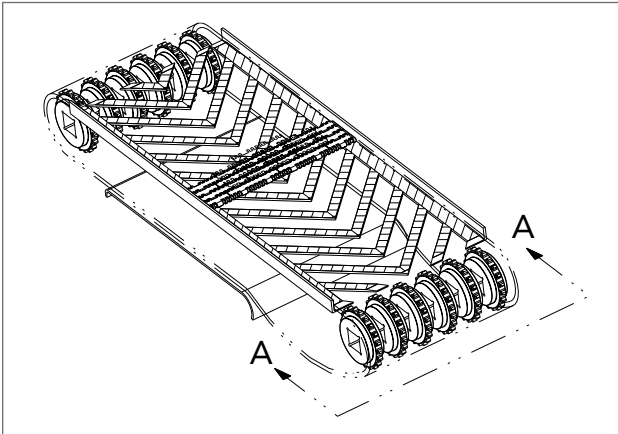

Chevron pattern

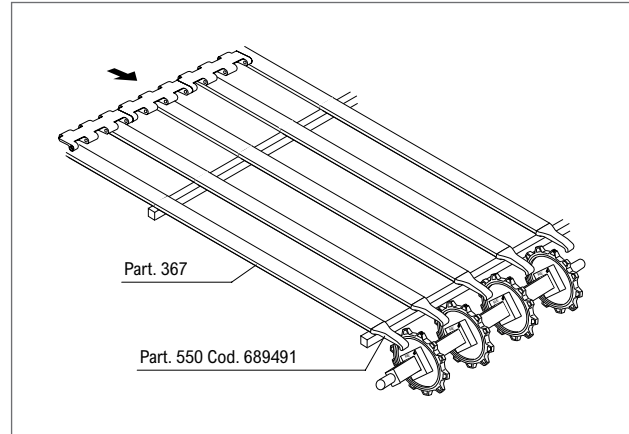

Inline pattern

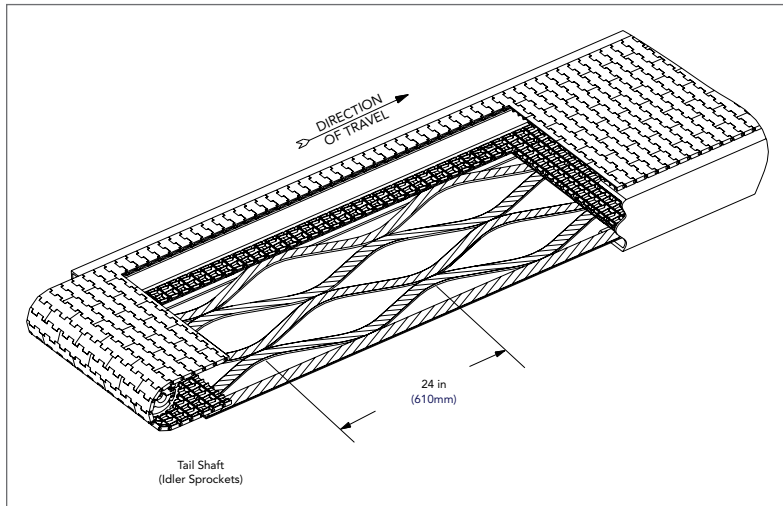

Serpentine pattern

General

- ⇒ Stainless Steel wearstrips are recommended in abrasive environments such as broken glass
- ⇒ For most all other applications, UHMW-Polyethylene wearstrips are recommended
- ⇒ Chevron or serpentine patterns are recommended to maximize chain life because they provide uniform wear across the full width of the chain

Flatness and Cleanliness

- ⇒ All wearstrips must be flat and flush with each other to avoid catch points with the chain
- ⇒ Using a string level, transit or laser device, level the carry way wearstrips in all directions
- ⇒ Wearstrips should have rounded lead in edges, be the same height, and contain no sharp edges
- ⇒ Care should be taken to cover the conveyor whenever cutting or construction activity is being done nearby. This will keep abrasive contaminants out of the wearstrips.
- ⇒ Wearstrips should be kept clean
- ⇒ Replace wearstrips if they are worn

Contact Rexnord Application Engineering for more information 1.262.376.4800

WEARSTRIPS

Wearstrip Thermal Expansion

⇒ UHMWPE wearstrips will contract and expand due to environmental conditions. A 1/4" to 3/8" gap should be allowed between sections. Suggested methods to accommodate this are shown below.

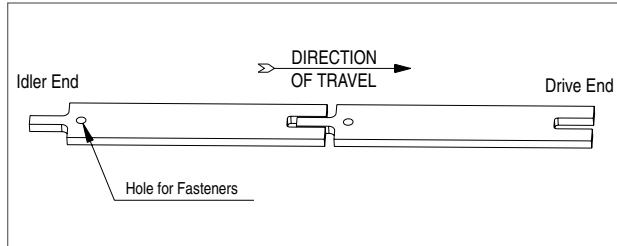

Tongue and groove wearstrip

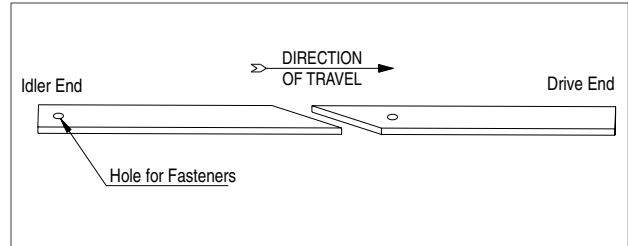

Angle cut wearstrip

CHAIN RETURN

Types of Returns

- ⇒ Chevron, serpentine or inline patterns are commonly used, but for wide tunnel machines (pasteurizers, warmers, coolers, etc), parallel running rotating rollers, static tubes or half-moon shoe supports are recommended. Rotating Rollers are preferred over static tubes or shoes. See diagrams below.
- ⇒ The rollers or return members must be mounted so that they are perfectly level, perpendicular to the chain centerline and parallel with each other. Adjust if required.
- ⇒ For recommended roller spacing, contact Rexnord Application Engineering
- ⇒ The rollers or return supports should be kept clean
- ⇒ All return rollers should be periodically checked to ensure they are rotating freely

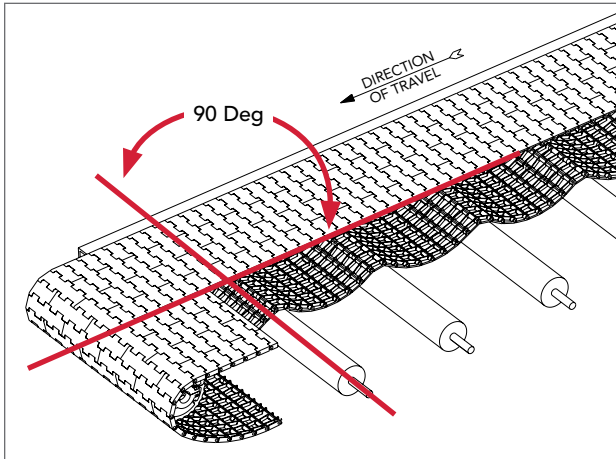

Rotating rollers

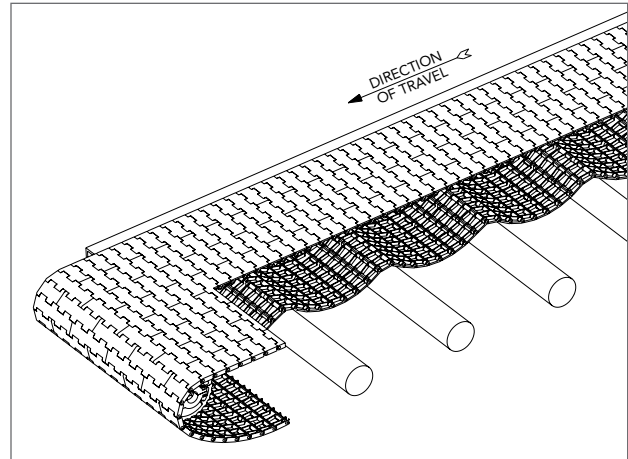

Static tubes or static half-round shoes

Return Way Entry Radius for Sliding Returns

- ⇒ Provide a generous entry radius to the return section in order to permit the chain to feed smoothly into the return ways
- ⇒ The entry radius should be greater than the minimum back-flex radius of the chain (refer to the [FlatTop Engineering Manual \(8rxEM-en\)](#) page [EM-MT-60](#))
- ⇒ At the entry of the return wearstrips, provide rounded corners to prevent catching or snagging of the chain flights
- ⇒ The following diagram should be followed

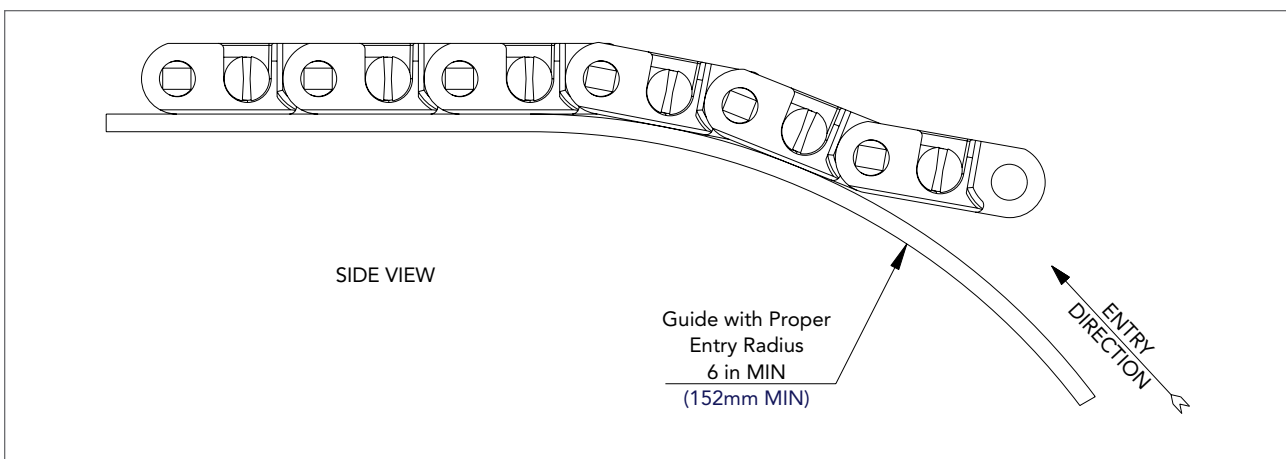

Entry radius for sliding returns

CHAIN THERMAL EXPANSION AND GUIDE CLEARANCE

Straight Running Assembled to Width Chains

- ⇒ Room Temperature Applications:
 - ♦ Guide Clearance (GC) = Chain Width + A
- ⇒ Elevated Temperature Applications (pasteurizers, warmers, coolers, etc.):
 - ♦ Actual width increases by an amount that is dependent upon temperature, chain width and the plastic coefficient of thermal expansion

| Coefficients of Thermal Expansion | | |
|-----------------------------------|--------------------|-------------|
| Material | inches / Feet / °F | mm / m / °C |
| Acetal | 0.0006 | 0.09 |
| Polyethylene | 0.0015 | 0.23 |
| Polypropylene | 0.0010 | 0.15 |
| Nylon | 0.0005 | 0.07 |

| Standard Conveyor Guide Clearance | | | |
|-----------------------------------|------|-----------------|---------|
| Dimension A | | Conveyor Length | |
| inches | mm | feet | m |
| 0.38 | 9.7 | Up to 30 | Up to 9 |
| 0.63 | 16.0 | 30 to 50 | 9 to 15 |
| 0.75 | 19.1 | Over 50 | Over 15 |

Standard Conveyor Guide Clearance Calculation of GC at Elevated Temperatures

Example:

- ⇒ Assume a 12 ft (3.6m) wide, 45 ft (13.5m) long pasteurizer operating at an average temperature of 190°F (88°C) and utilizing a polypropylene chain

- ⇒ The increase in the width (ΔW) due to the temperature of 190°F (88°C) can be found as shown:

English:

$$\Delta W = W \text{ (chain width)} \times \text{CTE} \times \Delta T$$

$$\Delta W = 12 \text{ ft} \times 0.0010 \text{ in/ft/°F} \times (190-70^\circ\text{F})$$

$$\Delta W = 1.44 \text{ in}$$

Metric:

$$\Delta W = W \text{ (chain width)} \times \text{CTE} \times \Delta T$$

$$\Delta W = 3.6\text{m} \times 0.15\text{mm/m/°C} \times (88-21^\circ\text{C})$$

$$\Delta W = 36.6\text{mm}$$

- ⇒ Allow for standard clearance, "A", based upon conveyor length

- ⇒ For a 45 ft (13.5m) long conveyor, A = 0.63 in (16.0mm) (from the Standard Conveyor Guide Clearance Table)

- ⇒ The total GC for this example is:

$$\text{GC} = \text{Chain width at room temperature} + \text{expansion due to temperature} + \text{standard clearance (A)}$$

English:

$$\text{GC} = 144 \text{ in} + 1.44 \text{ in} + 0.63 \text{ in} = 146.07 \text{ in}$$

Metric:

$$\text{GC} = 3658\text{mm} + 36.6\text{mm} + 16.0\text{mm}$$

$$= 3710.6\text{mm}$$

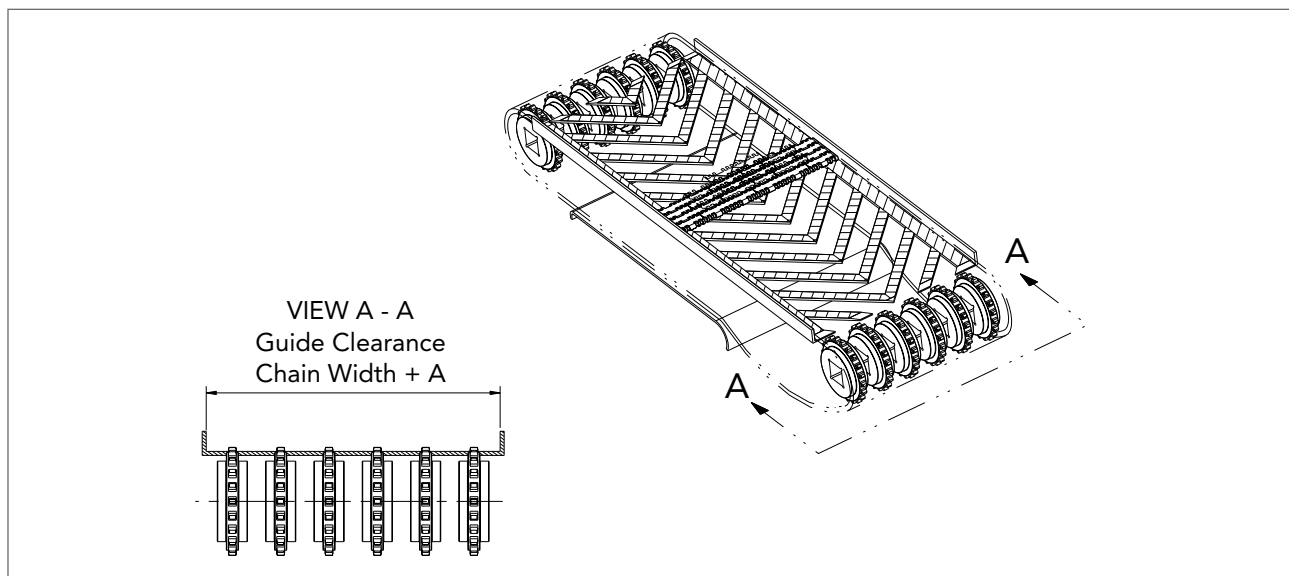

CHAIN THERMAL EXPANSION AND GUIDE CLEARANCE

Molded To Width and Side-Flexing Chains

⇒ Guide clearance is critical for both straight and side-flexing chains. For guide clearance dimensions of Positrack chains, see tables below or [Product Catalog \(8rxCAT-en\)](#). For guide clearance of wide, assembled to width MatTop chains at elevated temperatures, see page 32 of this manual.

Positrack

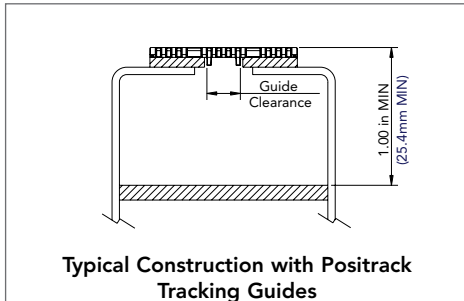

Molded to Width MatTop Chains with Positrack Tracking Guides

⇒ MatTop Chains with Positrack tracking guides are usually guided in a manner similar to TableTop Chains

| Chain Guide Clearance | | | | | | |
|-----------------------|----|-------------|---|---|---|--|
| Chain Style | | 1505 DTS PT | 5705 (MTW) PT 5706 (MTW) PT 5705 DTS PT | 7705 (MTW) PT 7706 (MTW) PT 7705 (MTW) PT 7705 DTS PT 7705 DTS-R PT | 8505 (MTW) PT 8506 (MTW) PT 8505 DTS PT | 1000 FTMTW DP 1000 FGMTW DP 1000 FT FreeFlow 1000 FG FreeFlow |
| Guide Clearance | in | 2.13 | 1.75 | 1.75 | 1.75 | 1.75 |
| | mm | 54.1 | 44.5 | 44.5 | 44.5 | 44.5 |

Assembled to Width MatTop Chains with Positrack Tracking Guides

⇒ For further recommendations, see the [Product Catalog \(8rxCAT-en\)](#)

| Chain Guide Clearance | | | | |
|-----------------------|----|---------------------|------------------------------|-----------------------|
| Chain Style | | 7705 PT End Modules | 8506 and 8506 PT End Modules | 1000 FT DP, 1000 FGDP |
| Guide Clearance | in | 1.75 | 1.75 | 1.75 |
| | mm | 44.5 | 44.5 | 44.5 |

TAB Style (5935/5936 and 8505/8506)

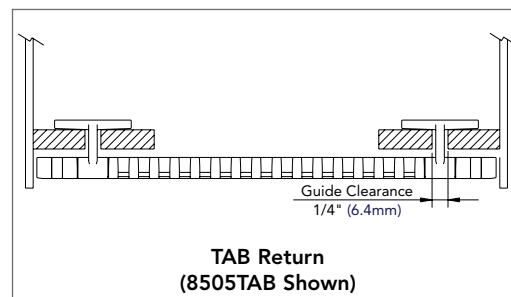
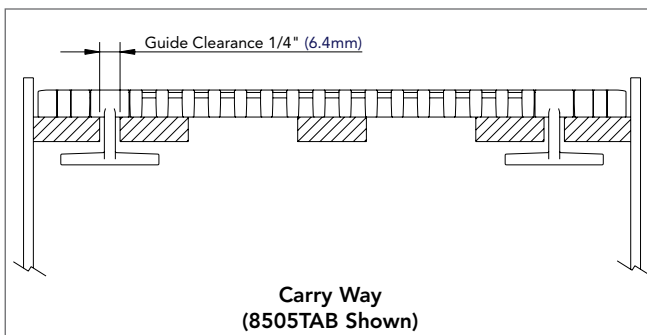

- ⇒ TABs hold chain down in incline or decline applications
- ⇒ TABs hold chain in place for vacuum applications

Contact Rexnord Application Engineering for more information 1.262.376.4800

▶ CHAIN THERMAL EXPANSION AND GUIDE CLEARANCE

▶ Side-Flexing — TAB, GT and Bearing Designs (7956 Chain Series) — ST (Sidetab) (7960 Chain Series)

⇒ Positive retention

⇒ For further design recommendations, see the 7956 design manual (8rx7956dm-en) , or the 7960 Design Manual (FT3-0017960)

▶ 1625B-TAB Chain

⇒ Positive retention

⇒ For further recommendations, see the 1625B-TAB section in the [Product Catalog \(8rxCAT-en\)](#) and 1625B-TAB Design Manual, FT3-002 1625B-TAB DM

▶ Side-Flexing — No TAB Design (7956, 7963 and 7966 Chain Series)

⇒ No hold down in the straight sections

⇒ Chain can be lifted in the straight section for ease in cleaning and maintenance

⇒ For further design recommendations, see the 7956 design manual (8rx7956dm-en) or the 7960 series design manual (FT3-0017960)

▶ Side-Flexing — Positrack Design (7526 Chain Series)

⇒ For further recommendations, see the 7526 section in the [Product Catalog \(8rxCAT-en\)](#) and 7526 Design Manual (8rx7526dm-en)

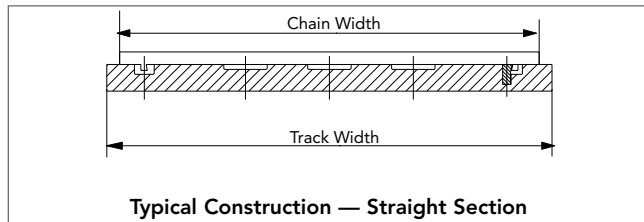

▶ Side-Flexing — 1200 Series (1255, 1265, 1275, and 1285 Chain Series)

⇒ See the 1200 Series Design Manual (FT3-004)

▶ SPROCKET INSTALLATION, MOUNTING AND LOCKING METHODS

▶ Round Bore Sprockets

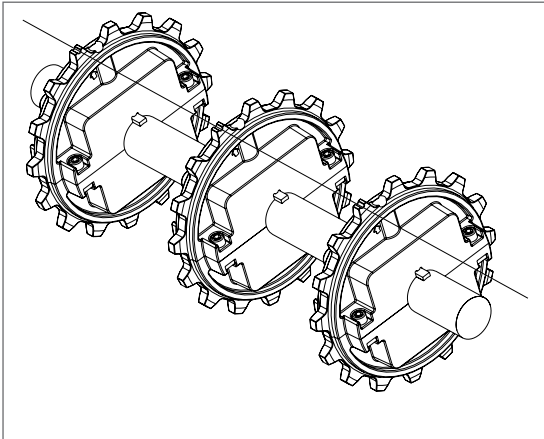

- ⇒ Use round bore sprockets on conveyors operating at room temperature
- ⇒ When installing the sprockets, make sure that all sprocket faces are positioned the same way on the shaft (shown in drawing)
- ⇒ After positioning all the sprockets in line with the sprocket tooth pockets in the chain, secure the sprockets with setscrews or set collars

▶ Square and Hex Bore Sprockets

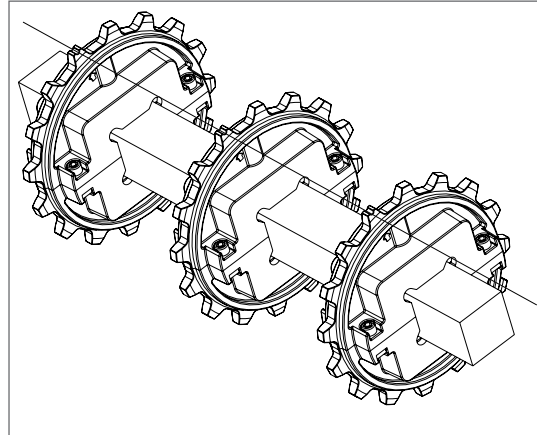

- ⇒ Use square bore sprockets on conveyors intended for use at elevated or lower temperatures (warmer, pasteurizer, cooler and freezer applications)
- ⇒ When installing the sprockets, make sure that all sprocket faces are positioned the same way on the shaft (shown in drawing)

▶ Locking Methods

- ⇒ It is generally recommended to lock the center sprocket(s) to the shaft using setscrews or set collars. The other sprockets should “float” axially.

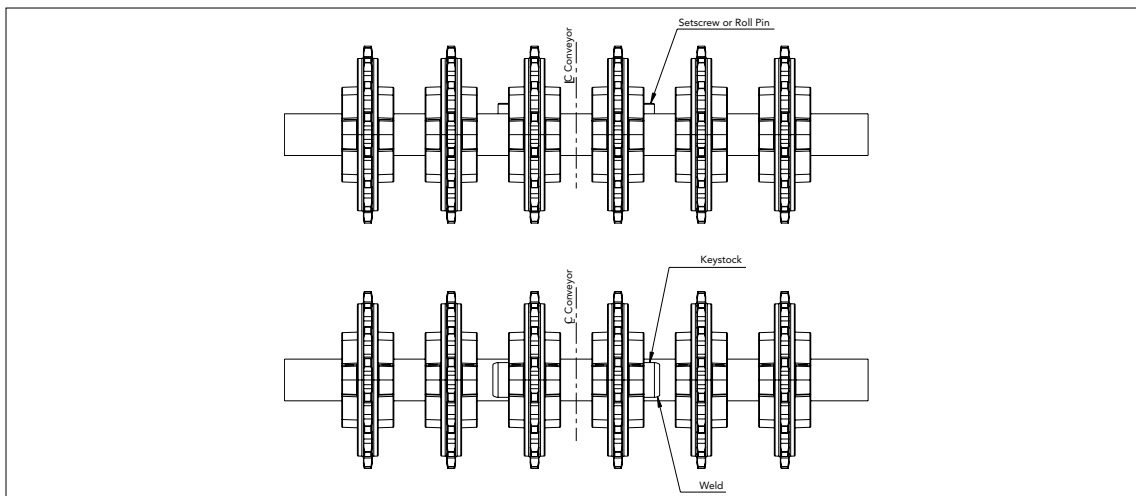

- ✓ Close up view of the center sprocket(s) indicates the method of locking the sprocket to the shaft (i.e. keystock, roll pin, snap rings, set collars).

- ⚠ CAUTION For 6085 chains, lock all sprockets in place.

SPROCKET INSTALLATION, MOUNTING AND LOCKING METHODS

Sprocket Installation and Locking Methods

- ⇒ Install the sprockets onto the shaft making sure that they all face the same way so that all the teeth are in line. Square shaft sprockets contain a timing mark to help ensure proper positioning as shown above.
- ⇒ All sprockets should be fixed on the shaft for room temperature application
- ⇒ For conveyors with fluctuating temperatures, lock only the center one or two sprockets. The other sprockets should float axially to allow for thermal expansion and contraction of the chain. Fixed sprockets can be locked in place using set screws, roll pins, welded blocks or shaft collars. Make sure that the locking method cannot come loose over time.

- ⇒ Locate the sprockets laterally along shafts to ensure that the sprockets line up with the proper sprocket pocket locations. This is accomplished easily by laying a short section of chain orientated in the correct direction of travel on the conveyor wearstrips near the idler and drive shaft sprockets. Slide the chain onto the sprockets to make sure the sprockets line up with the pockets in the bottom of the chain.
- ⇒ Tighten all the sprocket capscrews and keyway setscrews to the recommended torque settings below

| Capscrews | | | |
|-----------|-----------|----------|--------------------|
| | Bolt Size | Hex Size | Recommended Torque |
| English | 1/4-in | 3/16-in | 50 in-lb |
| | 3/8-in | 5/16-in | 75 in-lb |
| Metric | M 6 | M 5 | 5.7 N-m |
| | M 10 | M 8 | 8.5 N-m |

| Keyway Setscrew | |
|-----------------|--------------------|
| Hex Size | Recommended Torque |
| 1/8-in | 40 in-lb |
| 1/16-in | 40 in-lb |



It is critical to never mix split and solid sprockets on the same shaft because teeth will not be aligned



- ⇒ Where internal shaft bearings or shaft couplings are required, they may interfere with the proper sprocket locations. This will usually require that one or more sprockets be left out. In this case, provide other means of supporting chain at this location to keep chain from sagging in-between sprockets. This can be accomplished with an idler sprocket or machined UHMWPE drum.
- ⇒ If dual drives are utilized, it is critical to ensure that each pair is accurately synchronized and in phase
- ⇒ For sprocket pocket locations see Sprocket Location section in [FlatTop Engineering Manual \(8rxEM-en\)](#)

SPROCKET AND SHAFTDROP HEIGHT ADJUSTMENT

Sprocket and Wearstrip Location with Non-Raised-Rib Chains

- ⇒ The distance from the end of the wearstrip to the sprocket shaft centerline should equal dimension "C" (one chain pitch); otherwise, the wearstrip will interfere with the free articulation of the chain as it enters the sprocket
- ⇒ The leading edges of the wearstrip should be beveled
- ⇒ The following formulas and dimensions used in conjunction with the figure will give the proper shaft and wearstrip positioning

Sprocket Location For Conventional Chains:

$$A = (\text{Pitch Diameter}/2) - E$$

$$C = \text{One Chain Pitch (see table below)}$$

"C" equals one chain pitch which ensures support under chain at all times.

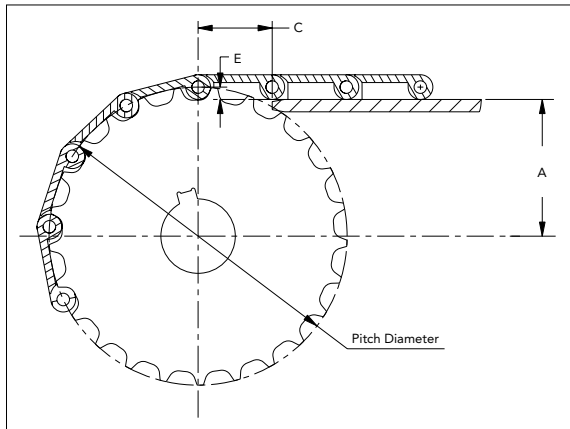

i Dimensions apply for both head and tail shafts

| Shaft Drop Values for Conventional Chain | | | | | |
|--|------------------------------|-------------|------|-------------|-------|
| Chain Series | Chain Number | C Dimension | | E Dimension | |
| | | in | mm | in | mm |
| 1000 | 1000FT/1000FG | 1.00 | 25.4 | 0.170 | 4.32 |
| 1010 | 1015 | 1.00 | 25.4 | 0.200 | 5.08 |
| 1200 | 1255/1265/1275/1285 | 1.25 | 31.8 | 0.250 | 6.35 |
| 1500 | 1503/1505/1506/1553 | 0.59 | 15.0 | 0.190 | 4.83 |
| 1625 | 1625B-TAB | 1.00 | 25.4 | 0.312 | 7.94 |
| 2010 | 2011/2015/2016 | 2.00 | 50.8 | 0.320 | 8.00 |
| 3000 | 3003/3004 | 2.50 | 63.5 | 0.438 | 11.11 |
| 3120 | 3125/3129 | 3.00 | 76.2 | 0.630 | 15.88 |
| 3180 | 3185 | 3.00 | 76.2 | 0.625 | 15.88 |
| 4700 | 4705/4706 | 1.50 | 38.1 | 0.250 | 6.35 |
| 5700 | 5705/5706 | 1.50 | 38.1 | 0.250 | 6.35 |
| 5930 | 5935/5936 | 0.75 | 19.1 | 0.170 | 4.32 |
| 5966 | 5966 | 1.50 | 38.1 | 0.250 | 6.35 |
| 5990 | 5995/5996/ 5998/5998HD | 2.25 | 57.2 | 0.360 | 9.14 |
| 6085 | 6085 | 2.00 | 50.8 | 0.310 | 7.87 |
| 6938 | 6938 | 0.75 | 19.1 | 0.170 | 4.32 |
| 6990 | 6995/6999 | 2.25 | 57.2 | 0.360 | 9.14 |
| 6990H | 6995H/6999H | 2.27 | 57.7 | 0.360 | 9.14 |
| 7526 | 7526 | 0.50 | 12.7 | 0.250 | 6.35 |
| 7700 | 7703/7705/ 7706/7708/7743 | 1.00 | 25.4 | 0.250 | 6.35 |
| 7700 | 7748 | 1.00 | 25.4 | 0.220 | 5.59 |
| 7950 | 7956 | 1.25 | 31.8 | 0.250 | 6.35 |
| 7960 | 7963/7966 | 1.50 | 38.1 | 0.375 | 9.53 |
| 8500 | 8503/8505/8506 | 0.75 | 19.1 | 0.170 | 4.32 |
| 9600 | 9608 | 1.50 | 38.1 | 0.380 | 9.65 |

Example:

For a 5996 chain utilizing a 14T sprocket:

$$A = (\text{Pitch Diameter}/2) - E$$

$$= (10.111 \text{ in}/2) - 0.360 \text{ in} = 4.696 \text{ in}$$

$$C = 2.25 \text{ in}$$

Metric:

$$A = (\text{Pitch Diameter}/2) - E$$

$$= (256.82\text{mm}/2) - 9.14\text{mm} = 119.27\text{mm}$$

$$C = 57.1\text{mm}$$

Tolerances:

$$A = +.03 \text{ in} / -.00 \text{ in} (+.8\text{mm} / -.0\text{mm})$$

$$C = +.25 \text{ in} / -.00 \text{ in} (+6.3\text{mm} / -.0\text{mm})$$



Above values are good only for sprockets mounted between support tracks. For sprockets mounted in line with support tracks:

$$C = \sqrt{\left(\frac{\text{O.D.}}{2}\right)^2 - (A-t)^2} + 0.125$$

A = (Pitch Diameter)/2 - E
 O.D. = Outside Diameter of Sprockets
 t = Wearstrip Thickness

- ⇒ Wearstrips in line with sprockets can also be angled back on the bottom for more clearance

▶ SPROCKET AND SHAFTDROP HEIGHT ADJUSTMENT

▶ Sprocket and Wearstrip Location with Raised-Rib Chains

- ⇒ The distance from the end of the wearstrip to the sprocket shaft centerline should equal dimension "C" (one chain pitch); otherwise, the wearstrip will interfere with the free articulation of the chain as it enters the sprocket
- ⇒ The leading edges of the wearstrip should be beveled
- ⇒ The following formula and dimensions used in conjunction with the figure will give the proper shaft and wearstrip positioning

▶ Sprocket Location for Raised-Rib Chains:

A = (Pitch Diameter/2) - E

C = One Chain Pitch (see table below)

D = (Pitch Diameter/2) + F

T = Comb Thickness (see Product Catalog for dimensions)

"C" equals one chain pitch which ensures support under chain at all times.

Example:

For a 5997 chain utilizing a 14T sprocket:

$A = (\text{Pitch Diameter}/2) - E$
 $= (10.111 \text{ in}/2) - 0.360 \text{ in} = 4.696 \text{ in}$

$B = 3.25 \text{ in}$

$C = 2.25 \text{ in}$

$D = (\text{Pitch Diameter}/2) + F$
 $= (10.111 \text{ in}/2) + 0.610 \text{ in} = 5.666 \text{ in}$

$T = 0.25 \text{ in}$

Metric:

$A = (\text{Pitch Diameter}/2) - E$
 $= (256.82 \text{ mm}/2) - 9.14 \text{ mm} = 119.27 \text{ mm}$

$B = 82.6 \text{ mm}$

$C = 57.2 \text{ mm}$

$D = (\text{Pitch Diameter}/2) + F$
 $= (256.82 \text{ mm}/2) + 15.49 \text{ mm} = 143.90 \text{ mm}$

$T = 6.4 \text{ mm}$

✓ Tolerances:

$A = +.03 \text{ in} / -.00 \text{ in} (+.8 \text{ mm} / -.0 \text{ mm})$

$C = +.25 \text{ in} / -.00 \text{ in} (+6.3 \text{ mm} / -.0 \text{ mm})$

$D = +.00 \text{ in} / -.03 \text{ in} (+.0 \text{ mm} / -.8 \text{ mm})$

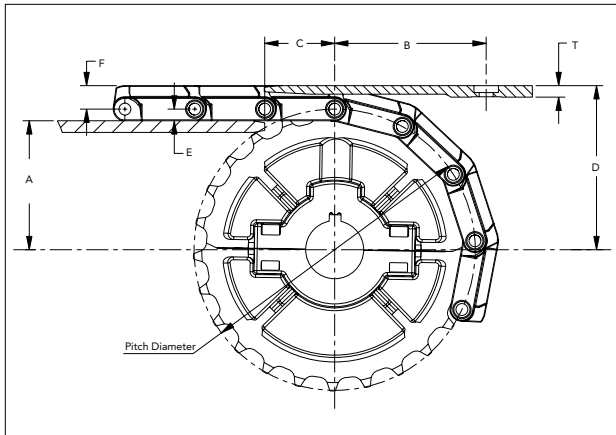

✓ "B" dimension is flexible. One must ensure that the comb fingers extend beyond the sprocket centerline to avoid transfer problems.

CAUTION ⚠ Mounting sprockets in line with wearstrips is not recommended for chains using comb transfer plates.

| Shaft Drop Values for Conventional Chain | | | | | | | | |
|--|-------------|------|-------------|------|-------------|------|-------------|-------|
| Chain Series | B Dimension | | C Dimension | | E Dimension | | F Dimension | |
| | in | mm | in | mm | in | mm | in | mm |
| 4707 | 3.25 | 82.6 | 1.50 | 38.1 | 0.250 | 6.35 | 0.500 | 12.70 |
| 5997 | 3.25 | 82.6 | 2.25 | 57.2 | 0.360 | 9.14 | 0.610 | 15.49 |
| 8507 | 3.25 | 82.6 | 0.75 | 19.1 | 0.170 | 4.32 | 0.390 | 9.91 |

▶ Layout Dimensions for DTS Chains

⇒ See [FlatTop Engineering Manual \(8rxEM-en\)](#), pages EM-MT-75-78

COMB TRANSFER PLATE INSTALLATION, MOUNTING AND LOCKING METHODS

General

- ⇒ Ensure that the transfer plate mounting surface is thoroughly clean and free of all debris and residue
- ⇒ Any combs with broken teeth should be replaced. Broken teeth may be an indication of improper mounting or installation, or excessive broken glass
- ⇒ Clean out broken glass on a regular PM schedule
- ⇒ The following general installation guidelines should be followed

Transfer Comb Installation

Low-Temperature Application

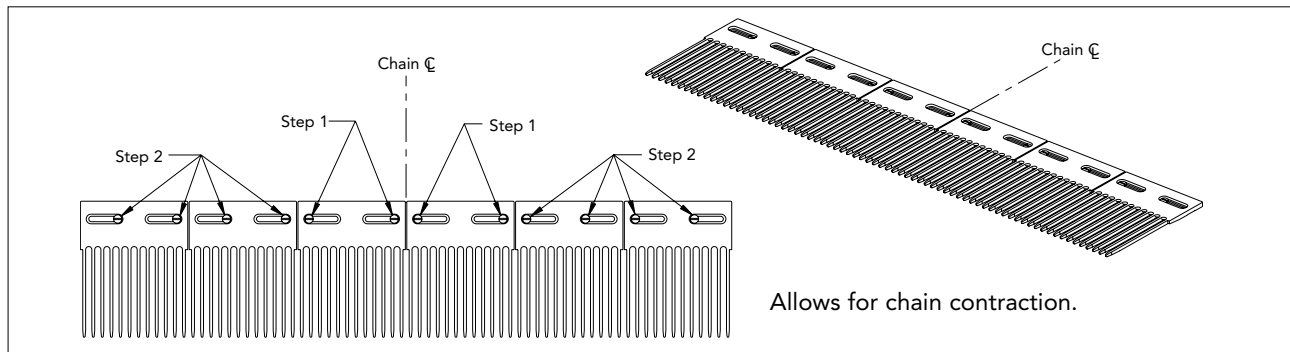

STEP 1 Secure the two centermost transfer plates in order to track the chain

STEP 2 Position the fasteners in the remaining transfer plates to the corresponding right side or left side of the slots to allow for contraction at low temperatures

High-Temperature Application

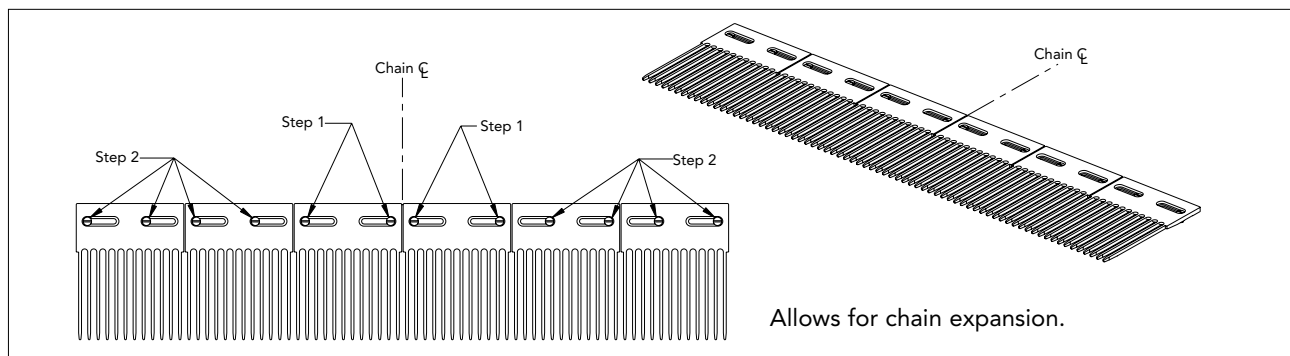

STEP 1 Secure the two centermost transfer plates in order to track the chain

STEP 2 Position the fasteners in the remaining transfer plates to the corresponding right side or left side of the slots to allow for expansion at high temperatures

i This arrangement will allow these transfer plates to move as required to accommodate changes in the chain width up to 1.50 in (38.1mm).

▶ COMB TRANSFER PLATE INSTALLATION, MOUNTING AND LOCKING METHODS

▶ Room Temperature Application

STEP 1 Secure the two centermost transfer plates in order to track the chain

STEP 2 The transfer plates to the left and right should have fasteners centered in the mounting slots

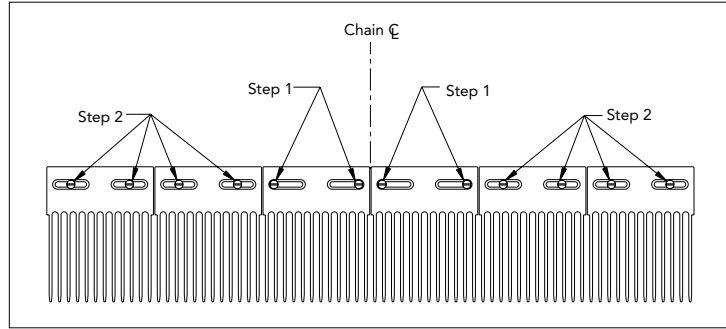

▶ Combs

⇒ A variety of styles and materials are available

⇒ Following the installation, test the level of the transfer combs with all the products conveyed within the tunnel. Adjust height and level of the infeed and discharge conveyors and comb support brackets as required to assure smooth container transfer. The tops of the transfer combs should be even with the top of the chain ribs. The transfer combs, infeed or discharge conveyor and main pasteurizer chain should all be level with each other.

CHAIN PRE-INSTALLATION CHECKLIST

⇒ It is recommended to review the checklist below prior to installing any of the chain

| Check when complete | What to Check for or do |
|---------------------|--|
| | Locate and identify the chain and sprockets. Familiarize yourself with the method of construction, assembly and disassembly (see pages 10-26 of this manual) |
| | Some chains have a required or preferred direction of travel. Identify the proper direction of travel for the chain (see FlatTop product catalog). Some chains have a direction of flow arrow molded directly on the chain. |
| | Check drive and idler shaft for level and Parallelism (see page 28 of this manual) |
| | Check that all wearstrips are installed properly, level, clean and smooth <ul style="list-style-type: none"> <input type="checkbox"/> All wearstrips must be flat and flush with each other to avoid catch points with the chain <input type="checkbox"/> Wearstrips should have rounded lead in edges, be the same height, and contain no sharp edges |
| | If applicable, check all of the return rollers or supports to ensure that they are clean, rotate freely (rollers only), level and parallel with each other (see page 31 of this manual) |
| | Inspect the shaft, bearings and couplings and ensure the following: <ul style="list-style-type: none"> <input type="checkbox"/> Condition of the shafts, bearings and couplings are satisfactory per manufacturer recommendations <input type="checkbox"/> Center support bearings (if applicable) are aligned and positioned correctly <input type="checkbox"/> If dual shafts are utilized, shaft couplings are used correctly (i.e. couplings should be rigid with no back-lash and both halves of square or keyed shafts are in time with each other) |
| | Check to make sure there is adequate guide clearance. This is particularly important for conveyors with elevated temperatures (pasteurizers, warmers, coolers, etc) (see page 32 of this manual). It is highly recommended to run a short section of chain (1-2 feet long) manually by hand through the entire carryway and return way and all corners (if applicable) to make sure there are no tight spots, obstructions, etc. This is not necessary for pasteurizers, warmers, coolers, etc. as long as the guide clearance is checked. |
| | Make sure all sprockets are properly mounted and locked down (see pages 35-36 of this manual). For MatTop chains with multiple sprockets, lay a short section of chain over the sprockets to make sure the sprockets are perfectly aligned with the pockets in the chain. |
| | Check that shaftdrop height is set correctly (see pages 37-38 of this manual). |
| | If applicable, make sure all comb transfer plates are properly mounted. The two center transfer combs should be fixed while all others should be able to move freely with thermal expansion or contraction of the chain (see pages 39-40 of this manual) |
| | All transfer points are critical! Check all transfer locations by laying chain in the tracks and sliding products through the transfer area by hand. Adjust as required. |
| | Clean the entire conveyor, sprockets and all wearstrips from any construction debris, dirt or metal chips that may have settled on the conveyor. Leaving these contaminants on the conveyor will cause premature chain wear. |
| | For side flexing conveyors requiring lubrication, apply a light coating of mineral oil or grease to the inside corner wearstrips thrust surface |
| | Gather the required tools and PPE necessary for the job (see general list below) |
| | To avoid personal injury, all machinery must be turned off and locked out, prior to any chain installation, inspection or maintenance |

▶ INSTALLATION TOOLS AND MATERIALS

⇒ The following is a suggested list of tools and materials required for a typical installation job

| | |
|--|--|
| Chain Assembly Tool | Chain assembly tools are available for the MapTop® Chain Series as shown below |
| Screwdrivers | Flat head screwdriver for chain assembly and disassembly |
| Pin Pullers | Contact Rexnord to obtain a pin puller (Part 4004) or use a similar threaded tool |
| Ratchets and Sockets | Sized for the chain assembly tool (or utilize an electric impact hammer drill and socket) |
| Electric Hand Drill and Gearbox Drill Bit Adapter | Used to drive the motor |
| Extension Cords | As required |
| String Levels | A transit or laser level can also be utilized to insure the wearstrips and shafts are level and aligned |
| Flat Straps | Long enough to pull the chain through the entire length of the tunnel |
| Rope and Winch | Used for pulling the chain through the tunnel |
| Spare Wearstrips | Only recommended for retrofit applications. Have spare wearstrips on-hand during the installation in the event that damaged wearstrip sections need to be replaced |
| Work Gloves | Heavy protective gloves are recommended |
| Rivet Tool | Only required for Fortrex™ 9200 chain installations |
| Stainless Steel Rivets | Only required for Fortrex 9200 chain installations. Supplied by Rexnord® (Part Number 820.00.09) |

▶ Chain Assembly Tools



5997 Chain Assembly Tool
Contact Application Engineering for recommendations

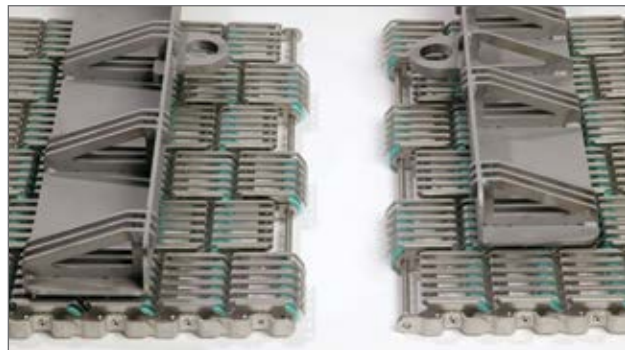

9200 Chain Assembly Tool
Part #820.00.18 (for 9217)
Part #820.10.15 (for 9227)

CHAIN INSTALLATION

- ⇒ Remove the chain from the shipping crates or boxes one section at a time. The chain is typically shipped in 5 foot or 10 foot rolls depending on the weight of the chain. For pasteurizers, warmers or coolers, the chain is typically shipped in 3 ft. (1 m) sections packed inside a wooden crate. Extra plugs and pins are shipped with each chain
- ⇒ Use care when handling the chain to avoid twisting or damaging it
- ⇒ Try to avoid dragging the chain on the floor where it can pick up debris
- ⇒ Insert one section of chain into the conveyor making sure to observe the proper direction of chain travel. The chain should move freely in the track.
- ⇒ Connect one chain section at a time through the entire carry and return way. For more detailed information on installing chains for pasteurizers, warmers or coolers, refer to the PWC engineering manual, bulletin number 8rxPWCdm-en.
- ⇒ Wrap the chain over the idler and drive sprockets, making sure that the teeth of all the sprockets are properly engaged in the respective sprocket pockets of the chain
- ⇒ Install and connect the last section of the chain hand tight. For wide tunnel machines (pasteurizers, warmers, coolers, etc), a mechanical chain puller(s) will be required due to the physical weight of these chains.
- ⇒ The chain slack may have to be adjusted later to ensure the catenary sag is correct (see next section)

▶ CATENARY SAG

▶ Purpose

- ⇒ Rexnord MatTop chains are designed to run with a catenary and therefore no take-ups or tensioning devices are required. The chains should be connected in ambient temperature.
- ⇒ The main function of the catenary is to allow a place for excess chain to accumulate
- ⇒ MatTop chains should never be run tight
- ⇒ The catenary sag should be measured when running
- ⇒ If the catenary sag is excessive or increases due to wear, it should be adjusted by removing links to obtain the proper sag (2 pitches must be removed for 1000 series and LBP 3000 series chains and any chain with Sideguards)
- ⇒ The catenary sag should be located as close to the drive as possible
- ⇒ The size of the catenary is critical and the following general guidelines should be followed

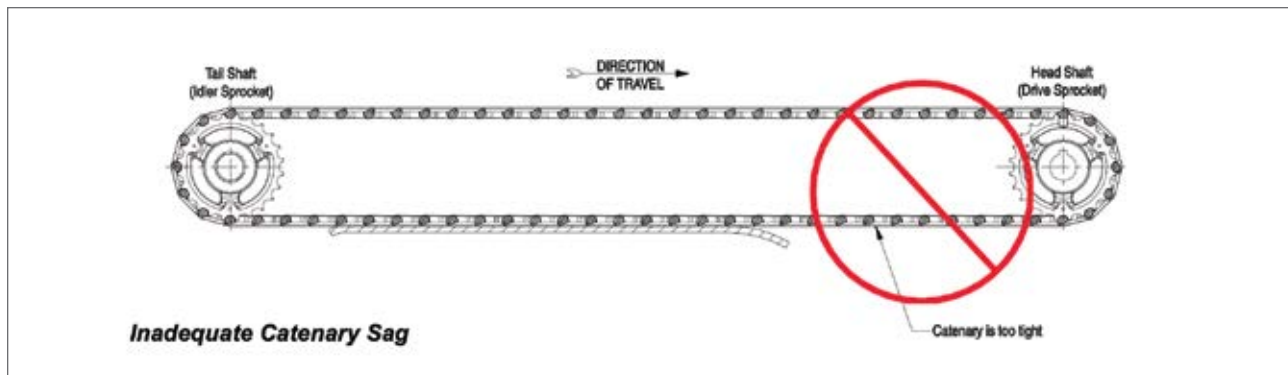
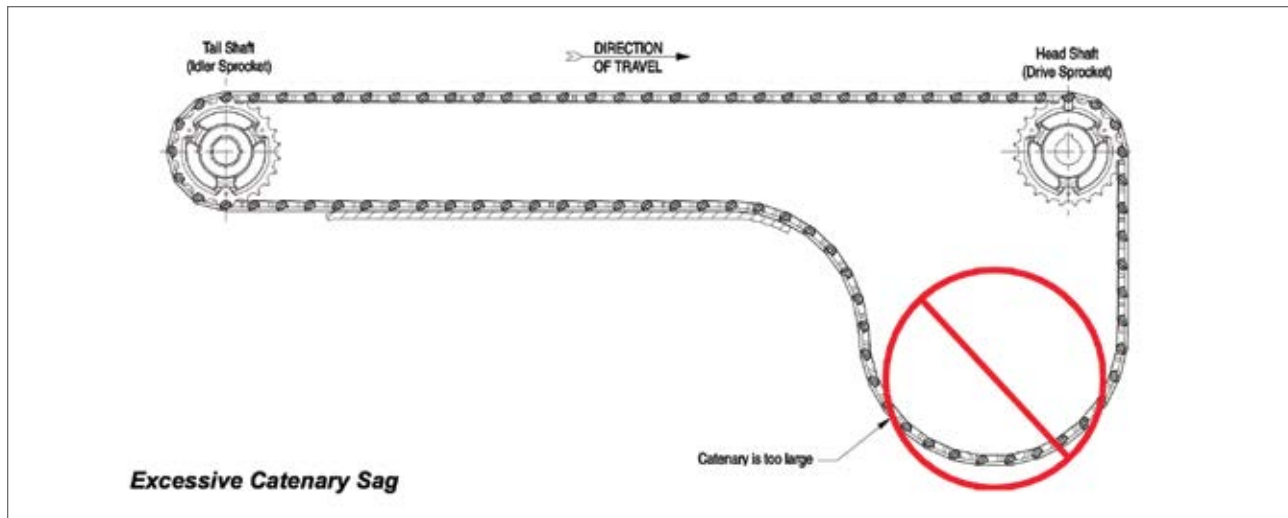

- ✓ After initial chain installation, run the chain until the equipment reaches operating temperature conditions for the catenary sag to settle in the correct position. After this time period it is recommended to check the catenary to ensure the proper sag is obtained. Adjust by adding or removing links as required.

CATENARY SAG

► Bi-Directional Bottom Drive Conveyors (for heavy-duty service)

⇒ The following general guidelines should be followed

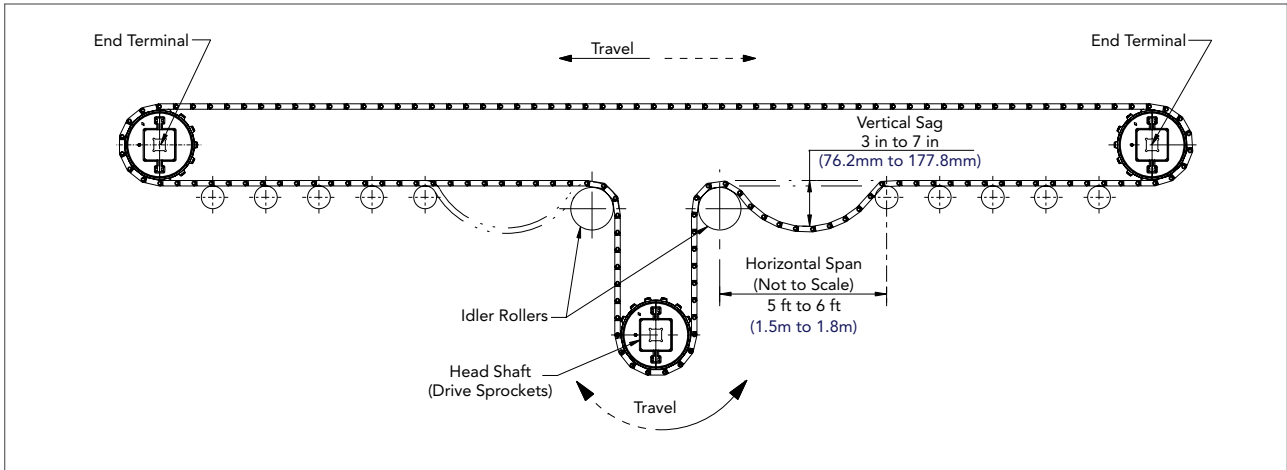

► Bi-Directional End Drive Conveyors (for light-duty service)

⇒ The following general guidelines should be followed

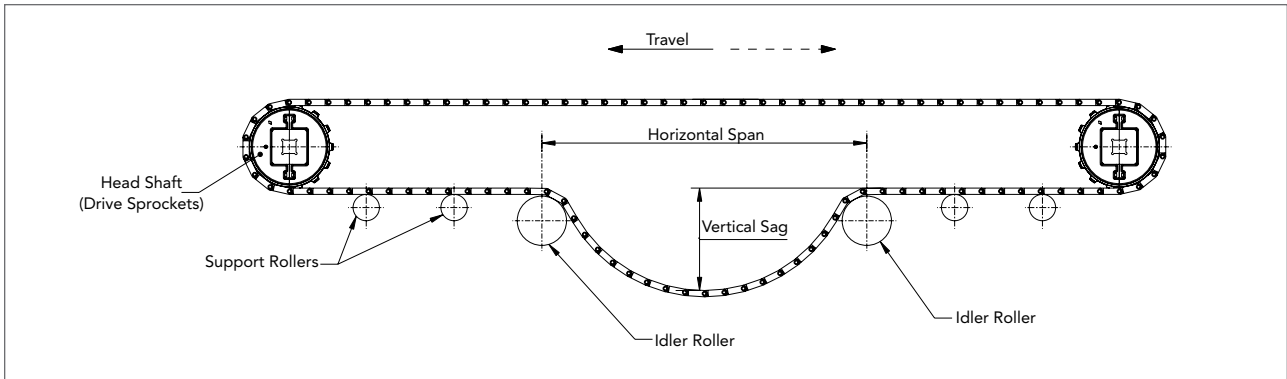

CATENARY SAG

Uni-Directional End Drive Conveyors

⇒ The following general guidelines should be followed

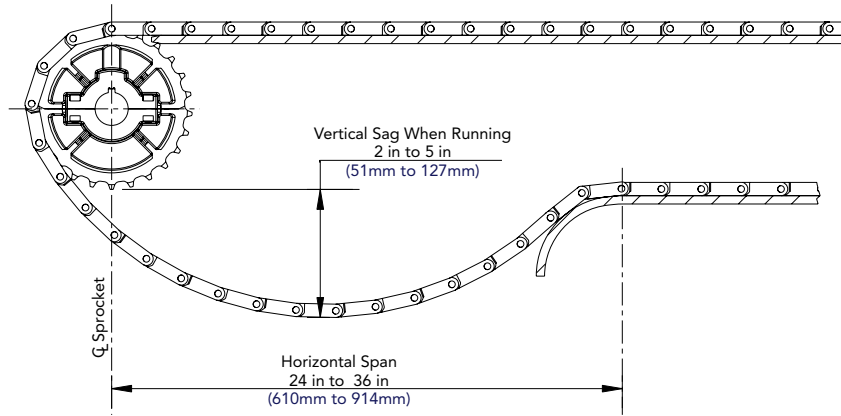

Conveyors with up to 40 ft (12m) centers and top load up to 15 lbs/ft² (75kg/m²)

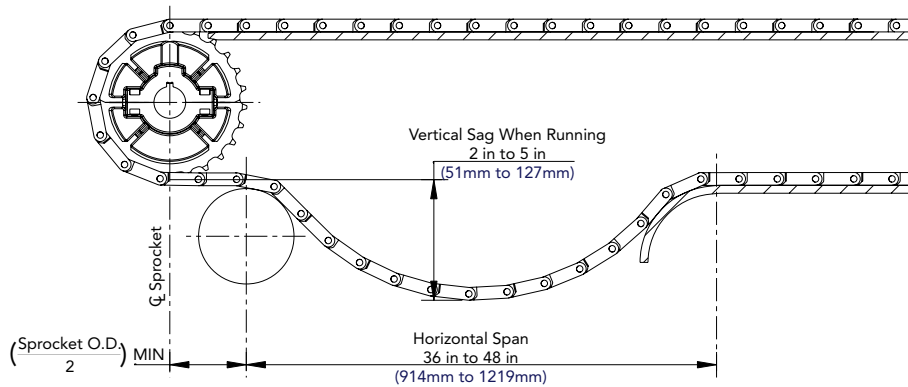

Conveyors with up to 60 ft (18m) centers and top load up to 20 lbs/ft² (100kg/m²)

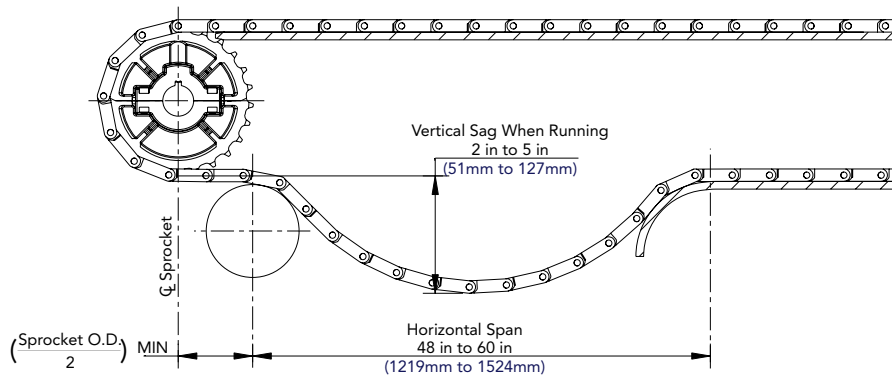

Conveyors with longer than 60 ft (18m) centers and top load in excess of 20 lbs/ft² (100kg/m²)

CONVEYOR START UP

➤ It is recommended to follow these steps when starting conveyors for the first time. This should be done well in advance of scheduled production start up.

- ⇒ Check to make sure all tools, loose hardware, etc are removed from the conveyor
- ⇒ Bump the start button briefly to check for proper motor rotation
- ⇒ Run the conveyor **without product** for 30-60 minutes. Listen for any unusual noises such as clicking or banging and also look for signs of any unusual operation. Refer to the trouble shooting guide for possible corrections if unusual noises occur or the system is not running smoothly.
- ⇒ Inspect the chain to ensure it is running properly, not hitting any obstructions, and tracking straight within the carry and return way
- ⇒ Inspect the chain to ensure it is properly driven by the sprockets (i.e. sprockets are in correct locations, there are no high spots, chain is not jumping, etc.)
- ⇒ Run the conveyor **with product**
- ⇒ Check the catenary sag while running and with product on the conveyor. Adjust the catenary as required to the above recommendations.
- ⇒ Stop the chain and repair, adjust or correct any problem areas that were found during the inspection process

CLEANING AND LUBRICATION GUIDELINES

General Cleaning Guidelines

In many applications a build-up may occur such as grease, dirt, debris or even spilled product like syrup, beer or soda. This may cause problems as listed below. Therefore, a thorough and regular cleaning procedure is very important to the successful operation of any conveyor line.

- ⇒ Damage to the conveyed product
- ⇒ Increased horsepower requirements
- ⇒ Chain pulsation
- ⇒ Excessive chain wear on the flights and in the joint or hinge areas
- ⇒ Rapid wear on the wearstrips
- ⇒ Accelerated sprocket tooth wear

- ✓ If conveyors are going to sit idle for a long time before start-up, they should be covered with plastic or drop cloth to minimize dirt and debris that can settle into chain and tracks.

Recommended Cleaning Frequency

- ⇒ Lubricated lines — lubrication generally provides a continual cleaning action, therefore, a weekly cleaning is recommended
- ⇒ Dry running lines — without the constant cleaning action of a lubricant, dirt and debris may build-up; therefore it is recommended that these lines be cleaned daily to obtain maximum sanitation and performance

General Guidelines for Cleaning Solutions

- ⇒ Recommended pH of 4-10
- ⇒ With plastic chains, avoid phosphoric acid (found in most stainless steel cleaners). Avoid chlorine (bleach), ammonia and iodine
- ⇒ Most hydrocarbons (mineral spirits, etc.) will not attack acetal chains
- ⇒ Refer to corrosion resistance guidelines on page 52 for further information



All cleaners and lubricants must be compatible with chain, wearstrip and sprocket materials. See the corrosion resistant guidelines on page 52. If chemicals are not listed, contact application engineering for assistance or consult with the cleaner/lubricant manufacturer for recommendations regarding compatibility with the different materials.

Methods of Cleaning

- ⇒ Periodic high pressure water rinse or steam cleaning should prove satisfactory. Spray the chain in place on the conveyor, both the carry and in the return sections. This is usually done with the conveyors running, but the chain can be stationary. For easy access to the underside of the carry and return chains, some manufacturers provide "clean out" holes in the side frames



It is recommended that steam should NOT be held on chains for prolonged periods. Chains may deform or become permanently damaged.



Keep water, steam and chemicals away from electrical disconnects, motors, photo eyes, or any other moisture sensitive equipment.

CLEANING AND LUBRICATION GUIDELINES

- ⇒ Warm water and soap are commonly used to clean the conveyor
- ✓ In some cases, such as PET bottle lines, cleaners or combination cleaner/lubricants are applied continuously or intermittently. Several types of automatic application systems are available.
- ✓ The main objective is to clean the chain carrying surface and underside as well as the wearstrips and tracks.
- ⇒ Chemical cleaners may be used if they are compatible with the chain material, refer to page 52 for guidelines

Strong caustic agents should not be used with plastic chains.



ALWAYS thoroughly rinse all cleaning agents completely off of the chain, sprockets and conveyor frame. Make sure that the underside of the chain is also rinsed thoroughly.

- ⇒ In extreme situations, it may be necessary to periodically clean the chains with a soft bristle brush. In these situations, clean the chain in place on the conveyor, both on the carry and in the return sections
- ⇒ Inspect conveyors often. Remove broken or jammed containers or pieces of containers as soon as they are detected. Use cleaning solutions to clean away excessive spillage

CLEANING AND LUBRICATION GUIDELINES

Pasteurizers, Warmers and Coolers Water Treatment and Cleaning Procedures

A pasteurizer is one of the harshest environments within a beverage filling plant because of the elevated temperature, constant submersion and chemical additives that are present within this process. Many of the biocides used to control biological growth also attack the plastics used in all conveyor chains, and the elevated temperature hastens this degradation (with every 50°F or 10°C the temperature increases, chemical reactions increase by a factor of 2 to 3!). Additional water properties, such as the pH, Alkalinity and Hardness can also further work together to create an environment where plastic chain life is compromised. Some chemical treatment is necessary to prevent the biology from overrunning the pasteurizer and fouling the process, but the well-being of the chain needs to be considered by keeping the chemical dosing to a minimum and choosing the right chemicals. The guidelines below should be followed to reduce the amount of damage done to the pasteurizer during normal operation and during boilout/cleaning procedures.

Water treatment & cleaning procedure

1. Do not use peroxides (H₂O₂) or Chlorine Dioxide (ClO₂). At normal concentrations the biocidal effects of peroxide are not great enough to destroy the bacteria within a pasteurizer, and chlorine dioxide is too volatile to control. They both are highly detrimental to polypropylene chains at elevated temperatures.
 2. Halogen-based Oxidizing Biocides (such as Chlorine and Bromine) are some of the most commonly used within pasteurizers. However, they could damage polypropylene chains at elevated concentrations. A dosing range between 0.5 – 2.0 ppm is typically sufficient to keep biological growth in check, and reduces the premature aging effect on the chain. The lowest possible concentration that controls the biology should be used (determined through onsite testing), and ideally an online Chlorine Analyzer or Redox Electrode should be used to guarantee the oxidizing agent is properly dosed.
 3. Consider using elevated temperatures and biodispersants (surfactants) for boilouts, as opposed to elevated temperature and an increased concentration of biocide. Most bacteria cannot survive in an environment greater than 140°F (60°C) for over one hour.
 4. Schedule boilouts as infrequently as possible. Use high-pressure water spray to dislodge large masses of biology once the pasteurizer has been properly sanitized.
 5. Ensure proper coverage of spray nozzles within pasteurizers to reduce “dead spots” in corners or areas where no treatment is possible. These areas oftentimes harbor a perfect environment for biology to flourish and will not be affected by increased chemical dosing — no matter how rigorous — since the biocide never actually reaches the mass.
 6. If white mineral deposits cause wear on the eyes and pins, the cause could be Hard Water as opposed to chemical attack. A water softener may be needed in the pasteurizer to reduce the amount of calcium carbonate scale on the chain. This can lead to premature chain elongation.
-  In applications where high chemical dosing is required either by regional regulations or by biological necessity, we recommend considering either our Rexnord® USP material (ultra-stabilized polypropylene) or our Rexnord Fortrex chain to optimize chain life. Contact your local Rexnord Application Engineering representative for additional information.

CLEANING AND LUBRICATION GUIDELINES

General Lubrication Guidelines

Lubrication is recommended whenever the application permits. It not only reduces friction, thereby reducing chain tension, but also greatly improves the wear life of the chain and wearstrips. Lubrication offers a constant cleaning effect of both the chain and wearstrip and can also reduce static.

General Recommendations

- ⇒ Lubrication should contact both the chain and wearstrip.
- ⇒ When lubricating side-flexing MatTop chains, the lubricant must be applied at the entrance of the outside corner track.

General Types of Lubricants

- ⇒ Water — Only utilize with corrosion-resistant materials. Can be used as a general lubricant; however, it is not as effective as other types due to friction and chain-cleaning properties.
- ⇒ Water soluble lubricants and soaps — Only utilize with corrosion-resistant materials. These are excellent lubricants which also help clean the chain.
- ⇒ Oil base lubricants — These are vegetable, mineral oils or grease which offer high lubricity. Can be used with plastic or metal materials. Recommended to be used on all metal chains whenever practical. Food grade oils are available.

Dry Film Lubricants

- ⇒ A dry lubricant system has many of the same benefits of a run-dry conveyor with the added benefit of a lower coefficient of friction. A dry lubricant is applied by an automatic system with dosing units that put very little lubricant on select areas of the conveyors. The lubricant can be water- or oil-based with Teflon, silicone or solid micro-particles. The preferred lubricant is an oil and water emulsion. The most critical part of the process is how the lubricant is applied on the chain. This is typically accomplished with the use of brushes, shoes or spray nozzles. The benefit of spray nozzles is the absence of contact with the chain, eliminating the possibility of trapped dirt or debris. The lubricant can also be applied to the inside of a curve for side-flexing conveyors. There are many dry lubricant products on the market which have been specifically formulated for either plastic or metal chains and container types.

- ⇒ While dry lubricants offer many advantages, conveyor cleanliness considerations should be taken into account since dry lubes do not provide a continuous cleaning process like traditional water and soap lubrication.

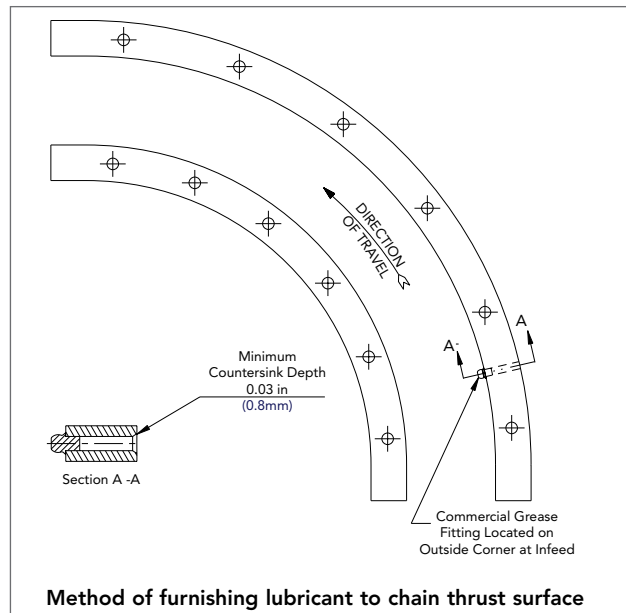

Selective Lubrication

- ⇒ In some applications, the presence of a lubricant cannot be tolerated. For these applications, it is recommended to utilize chains made of HP, PS or PSX acetal material with Nylatron corners, which offers the lowest coefficient of friction.

- 📄 To eliminate or reduce lubrication, contact Rexnord Application Engineering to conduct a run-dry survey. 1.262.376.4800
- For more information on lubrication types, compatibility, methods, contact a lubricant manufacturer.

Contact Rexnord Application Engineering for more information 1.262.376.4800

CLEANING AND LUBRICATION GUIDELINES

Corrosion Resistance Guidelines

⇒ Whenever MatTop chains are exposed to any fluids, chemicals, cleaners, etc, the chemical compatibility of the chemical and the specific MatTop material should be looked into. Acetal based chain materials are particularly prone to chemical attack. Chemical concentrations and elevated temperatures have a major influence on the acceptability of the chemical. Whenever uncertain about the chemical compatibility of certain cleaners or fluids with Rexnord chain, submit the following information to Rexnord Application Engineering so a determination can be made:

1. The chemical MSD sheet
2. Concentration (PPM) with water
3. Temperature the chain is exposed to
4. The duration the chemical is applied to the chain (or is it continually applied)
5. How often the chemical is applied to the chain
6. Is the chemical rinsed with clean water after the cleaning procedure

▶ NORMAL WEAR, CHAIN ELONGATION AND REPLACEMENT GUIDELINES

▶ General Notes

- ⇒ It is normal for all chains to wear
- ⇒ If a chain is properly selected and applied, it will typically wear out before it fails from fatigue
- ⇒ As a general rule of thumb, a chain can accommodate a minimum of 3% pitch elongation until it has to be replaced. At some point after 3%, the chain will start to jump (skip teeth) on the drive sprocket(s).
- ⇒ Sprockets will also wear over time
- ⇒ New sprockets should be installed whenever new chain is installed

▶ Various Modes of Wear

- ⇒ Chain pitch elongation (caused by a combination of pin and eye wear — see diagram below)

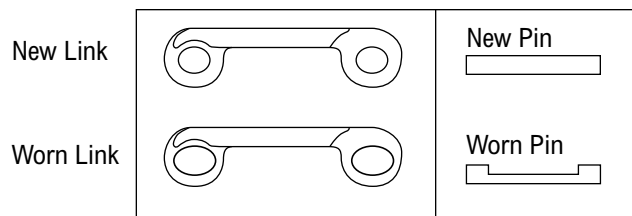

- ⇒ Wear to the top surface of the chain (applications with sliding return and/or accumulation — see example photos below)



- ⇒ Wear to the bottom surface of the chain (see example photo below)



- ⇒ Thrust surface or PV wear (applications with side-flexing chains)



▶ NORMAL WEAR, CHAIN ELONGATION AND REPLACEMENT GUIDELINES

▶ How to measure chain pitch elongation

Step 1 Determine the nominal chain pitch of your specific chain (see table below)

| Nominal Chain Pitch (P) | | Chain Series |
|-------------------------|------|------------------------------|
| (in) | (mm) | |
| 0.50 | 12.7 | 7526 |
| 0.59 | 15.0 | 1500 |
| 0.75 | 19.1 | 5930, 6930, 8500 |
| 1.00 | 25.4 | 1000, 1010, 1625, 7700 |
| 1.25 | 31.7 | 1200, 7956 |
| 1.50 | 38.1 | 4700, 5700, 5960, 7960, 9600 |
| 2.00 | 50.8 | 2010, 6080 |
| 2.25 | 57.2 | 5990, 6990, 9200 Fortrex |
| 2.27 | 57.7 | 6990H |
| 2.50 | 63.5 | 3000 |
| 3.00 | 76.2 | 3100 |

Step 2 Count "N" link rows. With a Tape Measure, measure the length from the leading edge of the first link to the leading edge the N+1 link (Dimension A, as shown below). *Note: You will get a more accurate result if you measure a longer distance. It is recommended to measure a minimum of 50" to 150" of chain length.*

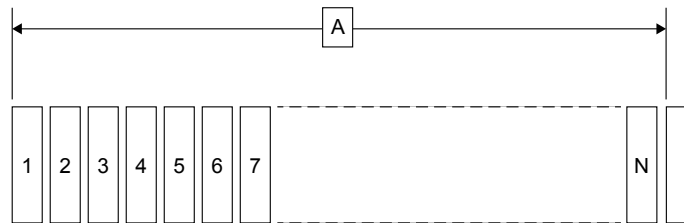

Step 3 Determine what your chain length was when it was new, using formula below:

$$\text{Chain length new (B)} = N \times P$$

Where:
B = What the chain length was when new
N = The number of chain links measured
P = Nominal chain pitch (from table above)

Step 4 Determine what your chain elongation is, using formula below:

$$\text{Chain elongation (\%)} = \frac{(A - B)}{B} \times 100$$

Where:
A = Actual measured chain length (from step 2)
B = The chain length when new (from step 3)

From this, and knowing how long your chain has been in service, the total estimated chain life and the remaining chain life can be determined, using the formula below:

$$\text{Total Estimated chain life (Years)} = \frac{(\# \text{ years in service} \times 3\%)}{\text{Chain elongation (\%)}}$$

▶ NORMAL WEAR, CHAIN ELONGATION AND REPLACEMENT GUIDELINES

| | | |
|----------|-----------------------------------|-------------------|
| Example: | Chain: | HP7705-12 |
| | Years in service: | 4 |
| | Nominal Chain Pitch: | 1.0" |
| | Number of pitches measured (N): | 50 |
| | Chain length when new (B): | 50 x 1.0" = 50.0" |
| | Actual measured Chain length (A): | 50.62" |

$$\text{Chain elongation (\%)} = \frac{(50.62 - 50)}{50} \times 100 = 1.24\%$$

$$\text{Total Estimated chain life (Years)} = \frac{(4 \times 3\%)}{1.24\%} = 9.68 \text{ years (or 5.68 years more life remaining)}$$

▶ Replace Chain and Sprockets When Any of the Following Apply

- ⇒ Chain pitch elongation reaches 3%, or chain starts to jump on the drive sprockets
- ⇒ The chain top surface has worn halfway to the MatTop pin
- ⇒ The chain bottom surface has worn halfway to the MatTop pin
- ⇒ The top surface has become scalloped, causing instability of conveyed products
- ⇒ Side transfers from one chain to another become an issue (one chain worn more than the other)
- ⇒ When chain wear starts causing product transfer issues
- ⇒ The conveying surface becomes uneven through wear
- ⇒ The chain thrust surface (side-flexing chains only) has excessive wear exposing pins or PV failure has occurred
- ⇒ Sprocket Teeth have worn away or developed a hooked profile

- ✓ When replacing chains insure that the correct material and style are specified. Refer to specifications of the OEM to determine the correct material and style.
- ✓ When installing replacement chain, follow the entire procedure outlined in the installation section on pages 41-43.

▶ Replace Wearstrips When Any of the Following Apply

- ⇒ The surface has worn away and/or exposed any screws, rivets or other types of fasteners
- ⇒ The surface has become rough
- ⇒ The surface is embedded with abrasive particles

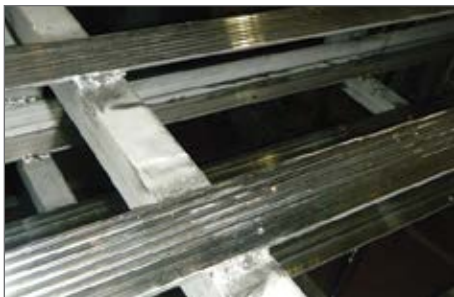

Grooved wearstrip

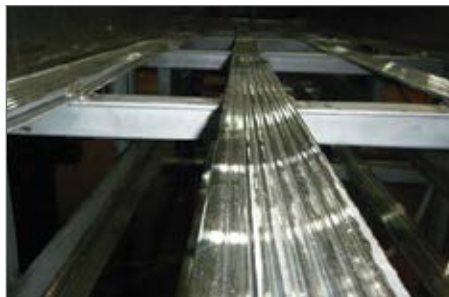

Grooved wearstrip

Contact Rexnord Application Engineering for more information 1.262.376.4800

▶ MAINTENANCE AND INSPECTION SCHEDULE

▶ General Notes

⇒ Periodic maintenance is essential to ensure chain reliability and increased lifetime. A general recommended maintenance schedule is shown below that applies to all Rexnord MatTop chains. It is always recommended to replace or repair damaged product as soon as it is detected.

| Maintenance And Inspection Interval Guidelines | | | | |
|--|-------------------------|---------|---------------|----------|
| Maintenance Item | Interval Between Checks | | | |
| | Weekly | Monthly | Semi-annually | Annually |
| Clean conveyor of debris if necessary | X | | | |
| Check catenary sag, adjust as necessary | | X | | |
| Check chain for unusual grooves or wear | | X | | |
| Check to make sure return rollers are spinning | | | X | |
| Measure chain elongation (see page xx-xx) | | | | X |
| Disconnect chain and check sprockets for wear | | | | X |

▶ TROUBLE SHOOTING GUIDE

| Symptom | Cause | Correction |
|---|--|---|
| <ul style="list-style-type: none"> <input type="checkbox"/> Sprockets don't slide on shaft with expanding chain | <ul style="list-style-type: none"> <input type="checkbox"/> Debris on shaft restricts movement <input type="checkbox"/> Set collars or limit device improperly located | <ul style="list-style-type: none"> <input type="checkbox"/> Clean shaft <input type="checkbox"/> Determine max expansion and set collars accordingly |
| <ul style="list-style-type: none"> <input type="checkbox"/> Chain not tracking straight | <ul style="list-style-type: none"> <input type="checkbox"/> Shafts are misaligned <input type="checkbox"/> Return rollers are skewed | <ul style="list-style-type: none"> <input type="checkbox"/> Align head & tail shaft to be parallel & horizontal (string level useful) <input type="checkbox"/> Adjust return rollers to be parallel & level |
| <ul style="list-style-type: none"> <input type="checkbox"/> Chain jumps sprocket teeth | <ul style="list-style-type: none"> <input type="checkbox"/> No provision for catenary <input type="checkbox"/> Improper shaft drop <input type="checkbox"/> Improper sprocket positioning | <ul style="list-style-type: none"> <input type="checkbox"/> Provide for catenary per Rex recommendation <input type="checkbox"/> Check and adjust shaftdrop drop per Rex recommendation <input type="checkbox"/> Sprockets must be positioned to engage tooth pocket on chain |
| <ul style="list-style-type: none"> <input type="checkbox"/> Chain breakage | <ul style="list-style-type: none"> <input type="checkbox"/> Impact loading <input type="checkbox"/> Over back-flexing of chain <input type="checkbox"/> Jam up <input type="checkbox"/> Pins coming out | <ul style="list-style-type: none"> <input type="checkbox"/> Don't drop load <input type="checkbox"/> Return roller too small diameter. Return rollers or shoes must meet minimum Backflex radius of chain <input type="checkbox"/> Clear cause of jam <input type="checkbox"/> End plugs missing Check and replace. Or, for some chain styles, melt end of pin to form a head. |
| <ul style="list-style-type: none"> <input type="checkbox"/> Transfer plate problems <input type="checkbox"/> Finger breakage <input type="checkbox"/> Finger climb top of chain ribs <input type="checkbox"/> Product tippage <input type="checkbox"/> Cracks thru mounting holes <input type="checkbox"/> Transfer plates don't move w/chain | <ul style="list-style-type: none"> <input type="checkbox"/> Screws too tight to allow plates to move <input type="checkbox"/> Fingers don't properly engage chain <input type="checkbox"/> Debris in between chain ribs <input type="checkbox"/> Plates are too loose | <ul style="list-style-type: none"> <input type="checkbox"/> Adjust screw tension <input type="checkbox"/> Use proper screw <input type="checkbox"/> Positioning transfer plates correctly <input type="checkbox"/> Clean off chain & remove wedged parts <input type="checkbox"/> Secure properly w/correct fastener to keep plate from "rocking". This rocking can cause failure thru mounting holes & product tippage <input type="checkbox"/> Clean mounting surface and check for level |
| <p>Note: The number one cause of chain transfer plate problems is the mounting surface not being straight and level. The number two cause is the plates are too tight or too loose.</p> | | |
| <ul style="list-style-type: none"> <input type="checkbox"/> Rapid or unusual chain wear | <ul style="list-style-type: none"> <input type="checkbox"/> Wear tracks embedded with debris | <ul style="list-style-type: none"> <input type="checkbox"/> Don't use plastic wear tracks on glass lines where breakage occurs <input type="checkbox"/> Don't use dead soft stainless steel. 1/4 Hard (20 Rc min) or 1/2 Hard (30 Rc min). |
| <ul style="list-style-type: none"> <input type="checkbox"/> Chain Pulsation <input type="checkbox"/> Chain jumps sprocket teeth | <ul style="list-style-type: none"> <input type="checkbox"/> Not uniform coefficient of friction <input type="checkbox"/> Improper catenary <input type="checkbox"/> Debris causes "sticking" locally <input type="checkbox"/> Idler sprockets don't turn freely <input type="checkbox"/> Inadequate guide clearance <input type="checkbox"/> Abrasive debris | <ul style="list-style-type: none"> <input type="checkbox"/> Lubricate <input type="checkbox"/> Don't mix plastic and metal wear tracks <input type="checkbox"/> Be sure catenary stays at the head end <input type="checkbox"/> Clean wear tracks <input type="checkbox"/> Check to be sure sprockets aren't tight on tail shaft. Re-bore if necessary. Clean shaft <input type="checkbox"/> Be sure chain is not being "pinched" by side guides. |
| <ul style="list-style-type: none"> <input type="checkbox"/> Rapid sprocket tooth wear | <ul style="list-style-type: none"> <input type="checkbox"/> Abrasive debris | <ul style="list-style-type: none"> <input type="checkbox"/> Most commonly a problem when using plastic sprockets. Change to metal sprockets or eliminate abrasive debris |

REXNORD PASTEURIZER CHAIN ANALYSIS CAPABILITIES

Rexnord® realizes that the unexpected down time for any product is unacceptable to our customers and that providing information on the life of a chain is a huge benefit, especially on critical pieces of equipment such as pasteurizers. Rexnord is able to assist our customers by providing a pasteurizer chain life analysis so installation of new chains can be scheduled up front and down time can be avoided.

As a service to our customers we can evaluate Rexnord pasteurizer MatTop® chain on a regular or routine basis as determined by the plant (typically every 12 months).

Analysis of the pasteurizer chain includes the following:

- ⇒ Test ultimate strength — pull test to obtain stress-strain curves
 - Review properties of the chain (i.e. determine if the chain is chemically or thermally degraded)
 - Review cleaners, biocides, corrosion inhibitors, descaling and other chemicals used in the pasteurizer to determine compatibility with the chain and sprocket materials
- ⇒ Measure dimensional properties (i.e. pin diameter, thickness, etc.)
- ⇒ Conduct visual inspection to determine conveyor related issues (i.e. evidence of misalignment, obstructions, unusual wear patterns, etc.)
- ⇒ Review chain tension calculations and shafting requirements

This analysis is to help our customers determine existing chain life and to help predict when the chain needs to be replaced. Information within the report can also help to give recommendations to improve the overall life of the chain.

To request a pasteurizer chain analysis, contact Rexnord Application Engineering at flattop.tech.support@rexnord.com or 262-376-4800



866-REXNORD/866-739-6673 (Within the U.S.)
414-643-2366 (Outside the U.S.)
www.rexnord.com

Why Choose Rexnord?

When it comes to providing highly engineered products that improve productivity and efficiency for industrial applications worldwide, Rexnord is the most reliable in the industry. Commitment to customer satisfaction and superior value extend across every business function.

Delivering Lowest Total Cost of Ownership

The highest quality products are designed to help prevent equipment downtime and increase productivity and dependable operation.

Valuable Expertise

An extensive product offering is accompanied by global sales specialists, customer service and maintenance support teams, available anytime.

Solutions to Enhance Ease of Doing Business

Commitment to operational excellence ensures the right products at the right place at the right time.

REXNORD

Rexnord Company Overview

Rexnord is a growth-oriented, multi-platform industrial company with leading market shares and highly trusted brands that serve a diverse array of global end markets.

Process & Motion Control

The Rexnord Process & Motion Control platform designs, manufactures, markets and services specified, highly engineered mechanical components used within complex systems where our customers' reliability requirements and the cost of failure or downtime are extremely high.

Water Management

The Rexnord Water Management platform designs, procures, manufactures and markets products that provide and enhance water quality, safety, flow control and conservation.