

# BR15



UPC Code: 07847781975

Country Of Origin: Mexico

\*Eligible for ARRA funded projects > \$7,443,000

NEMA:  
5-15R



# BR15

## Brand Features

Leviton's line of Heavy-Duty Specification Grade receptacles are designed and manufactured to withstand the most demanding environments. Available in a wide variety of configurations, including isolated ground, tamper-resistant, etc., these Commercial Grade devices are the electrical contractor's choice for use in hotels, schools, hospitals and commercial office buildings.

## Item Description

15 Amp, 125 Volt, NEMA 5-15R, 2P, 3W, Narrow Body Duplex Receptacle, Straight Blade, Commercial Grade, Self Grounding, Back & Side Wired, Steel Strap - Brown

## Technical Information

### AC Horsepower Ratings

**At Rated Voltage:** 1/2 HP

### Electrical Specifications

**Dielectric Voltage:** Withstands 2000V per UL498

**Grounding:** Self-Grounding

**Temperature Rise:** Max 30C after 100 cycles OL at 150 percent rated current

**Voltage:** 125 Volt

**Amperage:** 15 Amp

**Current Limiting:** Full Rated Current

**Wire:** 3

**Pole:** 2

### Environmental Specifications

**Operating Temperature:** -40C to 60C

**Flammability:** Rated V-2 per UL94

### Material Specifications

**Strap Material:** Zinc-Plated Steel

**Face Material:** Nylon

**Body Material:** Nylon

**Ground Clips:** Brass-Plated

**Terminal Screws:** Brass 10-32

**Color:** Brown

**Line Contacts:** Brass Triple-Wipe .031 Thick

**Grounding Screw:** Brass 8-32

**Clamp Nuts:** Zinc-Plated Steel

### Mechanical Specifications

**Product ID:** Ratings are permanently marked on device

**Terminal ID:** Brass-Hot, Green-Ground, Silver-Neutral

**Termination:** Back & Side

**Terminal Accom.:** 14-10 AWG

### Product Features

**Color:** Brown

**NEMA:** 5-15R

### Standards and Certifications

**Warranty:** 10 Year Limited

**CSA C22.2 No. 42:** File 152105

**ANSI:** C-73

**UL498:** File E13399

**NOM:** 057

**NEMA:** WD-1 & WD-6

## Dimensional Diagram

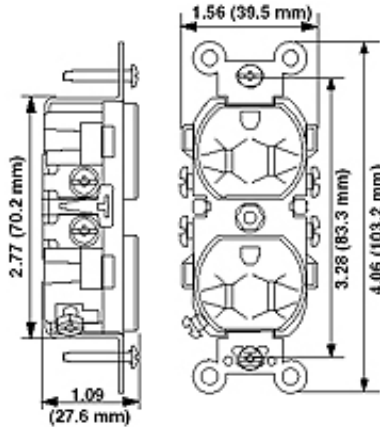

## Wiring Diagram

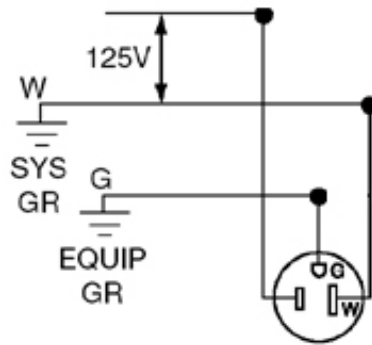

5-15R

## SPECIFICATION SUBMITTAL

|                      |                      |                      |
|----------------------|----------------------|----------------------|
| JOB NAME:            | CATALOG NUMBERS:     |                      |
| <input type="text"/> | <input type="text"/> | <input type="text"/> |
| JOB NUMBER:          | <input type="text"/> | <input type="text"/> |

### Leviton Manufacturing Co., Inc.

201 North Service Road, Melville, NY 11747

Teléfono: +1-800-323-8920 · FAX: +1-800-832-9538 · Tech Line (8:30AM-7:30PM E.S.T. Monday-Friday): +1-800-824-3005

### Leviton Manufacturing of Canada, Ltd.

165 Hymus Boulevard, Pointe Claire, Quebec H9R 1E9 · Telephone: +1-800-469-7890 ·

FAX: +1-800-824-3005 · [www.leviton.com/canada](http://www.leviton.com/canada)

### Leviton S. de R.L. de C.V.

Lago Tana 43, Mexico DF, Mexico CP 11290 · Tel.: (+52)55-5082-1040 · FAX: (+52)5386-

1797 · [www.leviton.com.mx](http://www.leviton.com.mx)

Visit our Website at: [www.leviton.com](http://www.leviton.com)

© 2012 Leviton Manufacturing Co., Inc. Todos los derechos reservados. Subject to change without notice.

### Leviton has a global presence.

If you would like to know where your local Leviton office is located please go to:

[www.leviton.com/international/contacts/](http://www.leviton.com/international/contacts/)



*\*Leviton is the smart choice, providing the most comprehensive range of solutions to meet the needs of today's residential, commercial and industrial buildings. Leveraging more than a century of experience, Leviton helps customers create sustainable, intelligent environments through its electrical wiring devices, network and data center connectivity solutions, and lighting energy management systems. From switches and receptacles, to daylight harvesting controls, networking systems, and equipment for charging electric vehicles, Leviton solutions help customers achieve savings in energy, time and cost, all while enhancing safety.*