

L-BALLS

- L-Balls
- L-Ball Dust Cover



Structure and Features

IKO L-Balls are self-aligning rod-ends consisting of a special zinc die-cast alloy body and a studded ball which has its axis at right angles to the body. They can perform tilting movement, oscillating movement and rotation with low torque, and transmit power smoothly due to uniform clearance between the sliding surfaces.

Their superior wear resistance assures stable accuracy for long periods of time, and maintenance is simple. They are very economical bearings.

For these reasons, they are widely used in link mechanisms in automobiles, construction machinery, farm and packaging machines, etc.

Types

L-Balls are available in various types as shown in Table 1.

Table 1 Type of L-Balls

Type	L-Ball		L-Ball dust cover
Model code	LHSA	LHS	PRC

L-Ball LHSA

These are compact rod-ends in which the spherical part of the ball-stud are held by the special zinc die-cast alloy body. There is a dust cover on the stud side and good quality lithium soap base grease is pre-packed. They can be run for long periods of time without re-lubrication and have excellent lubrication and anti-dust properties.

As shown in the structural drawing, these rod-ends are classified into 3 types by size. In addition, the ball-studs of LHSA 10 and lower are formed in one solid body, but those of LHSA 12 and higher, which are used under large loads, have the stud friction-welded to a high precision steel ball to give greater resistance to wear.

L-Ball LHS

These rod-ends have a friction-welded ball-stud, and a special zinc die-cast alloy body which houses the spherical surface of the high precision steel ball. There is an almost complete contact across the sliding surfaces, and the uniform clearance guarantees a stable bearing life.

An L-Ball dust cover can be attached to these rod-ends. If the rod-ends are lubricated with lithium soap

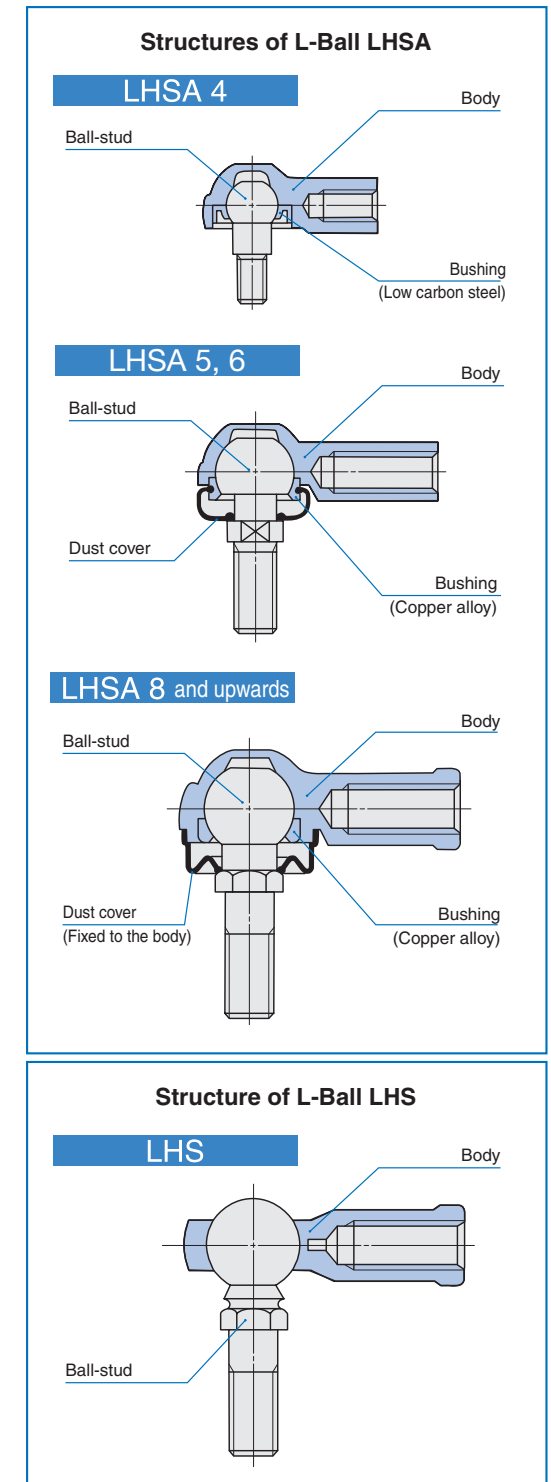

base grease, they have excellent lubrication and anti-dust properties and can run for long periods of time without re-lubrication.

When the L-Ball LHS is delivered with a dust cover on request, lithium soap base grease is prepacked.

L-Ball Dust Cover PRC

This is for the L-Ball LHS series. It is made of special synthetic rubber which has excellent resistance to oil and ozone. The cover offers very effective dust protection and prevents grease leakage.

Identification Number

The identification number of L-Balls consists of a model code, a size and any supplemental codes as shown in the examples.

Examples of identification number

Example 1 (Female thread of the body : In case of right-hand threaded)

Model code: LHS, Size: 8

Type: LHS, Size of thread (M8): 8

Example 2 (Female thread of the body : In case of left threaded)

Model code: LHS, Size: 8, Supplemental code: L

Left-handed thread: L

Example 3 (when a dust cover PRC is attached to LHS)

Model code: LHS, Size: 8, Supplemental code: D

With dust cover: D

Accuracy

The accuracy of L-Balls is shown in Table 2.

Table 2 Tolerance

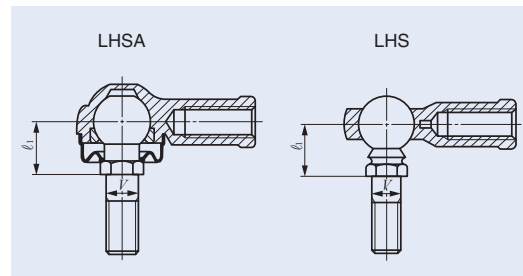

Type	Dimension symbol	Tolerance
LHSA	l_1	± 0.5
	V	0 - 0.2 ⁽¹⁾
LHS	l_1	± 0.4
	V	h9

unit: mm

Note⁽¹⁾ This dimensional tolerance applies to LHSA 5 and higher.

Selection of L-Balls

The static load capacity and maximum operating load of L-Balls are determined in consideration of the strength of the ball stud and the body. Accordingly, L-Balls are selected on the basis of the static load capacity C_s shown in the dimension table and the maximum operating load shown in Table 3.

Static load capacity

The static load capacity C_s shown in the dimension table represents the allowable axial force F which is determined by the mechanical strength of the ball-stud at the section 'A' under the bending moment due to the force F as illustrated in Fig. 1. If F increases beyond the static load capacity, deformation will begin at A, leading to breakage.

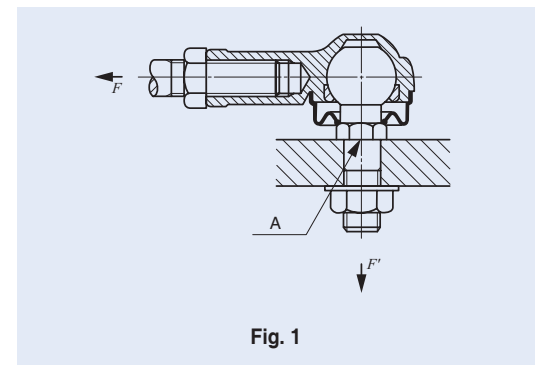

Maximum operating load

The strength of the body must also be taken into consideration when L-Balls are operated in a high-temperature or low-temperature atmosphere or receive repetitive loads of long duration or shock loads. A guideline for maximum operating load of L-Balls is shown in Table 3. When the fixing bolt in the main body is fixed and a load is applied in the direction of F' , the bending stress in the fixing bolt must be taken into consideration.

Table 3 Maximum operating load

Identification number	Maximum operating load	Identification number	Maximum operating load
LHSA 4	840	LHS 5	880
LHSA 5	1 180	LHS 6	1 080
LHSA 6	1 080	LHS 8	1 630
LHSA 8	1 900	LHS10	2 100
LHSA10	2 170	LHS12	2 620
LHSA10M	2 170	LHS14	3 190
LHSA12	2 790	LHS16	3 820
LHSA14	3 540	LHS18	4 610
—	—	LHS20	5 340
—	—	LHS22	6 460

unit: N

Lubrication

LHSA is prepacked with lubricating grease ALVANIA GREASE S2 (Shell Lubricants Japan K.K.). LHS is not provided with prepacked grease. Perform proper lubrication.

Operating LHS without lubrication will increase the wear of the sliding contact surface or cause seizure.

Operating Temperature Range

The maximum allowable temperature for L-Balls is +80°C.

Precautions for Use

- Tightening depth**
It is recommended that the tightening depth of the screw into the body is more than twice the nominal diameter of thread.
- Allowable tilting angle**
The allowable tilting angle is shown in Table 4.

Table 4 Allowable tilting angle

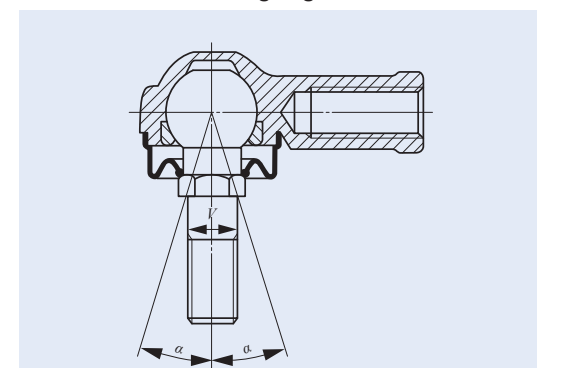

Nominal dia. mm	LHSA	LHS
V	α	α
4	15	—
5	17	15
6	17	17
8	18	18
10	19	19
12	19	19
14	20	20
16	—	20
18	—	21
20	—	20
22	—	21

unit: degree

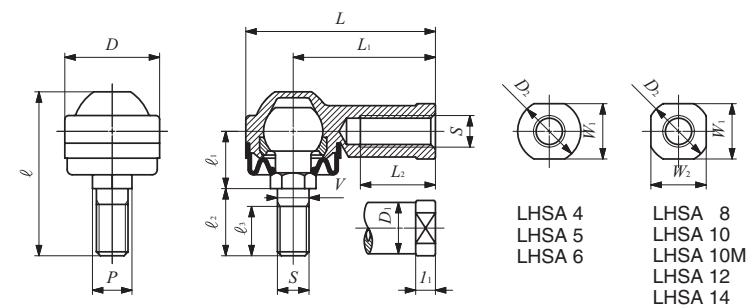

LHSA 4
LHSA 5
LHSA 6

LHSA 8
LHSA 10
LHSA 10M
LHSA 12
LHSA 14

Identification number	Mass (Ref.) g	Boundary dimensions mm												
		Thread S	V	D	L	L ₁	L ₂	l ₁	W ₁	W ₂	D ₁	D ₂	ℓ	P
LHSA 4	11	M 4×0.7	*4	14	25	18	8	4	8	—	8	10	19.5	*5.5
LHSA 5	27	M 5×0.8	5	17	38.5	30	16	5	10	—	10	12	32.5	8
LHSA 6	27	M 6×1	6	19	39.5	30	16	5	10	—	10	12	32.5	8
LHSA 8	64	M 8×1.25	8	24	48	36	19	5	14	14	13	16	41.5	10
LHSA 10	106	M10×1.25	10	28	57	43	23	6.5	17	17	15	19	49	12
LHSA 10M	106	M10×1.5	10	28	57	43	23	6.5	17	17	15	19	49	12
LHSA 12	180	M12×1.75	12	34	67	50	27	6.5	19	19	17.5	22	64	14
LHSA 14	260	M14×2	14	38	76	57	30	8	22	22	20	25	72	17

Remarks1. The item marked * is manufactured with a neck diameter of $\phi 3.4$. The item marked * is manufactured with a diameter of $\phi 5.5$ instead of a width across flats.
2. Provided with prepacked grease.

l ₁	l ₂	l ₃	Ball dia.	Static load capacity
				C _s N
7	7	5	8	880
12	13	10	11.112	1 180
12	13	10	11.112	1 670
14.5	17	12.5	15	4 380
16	21	17	19.05	7 400
16	21	17	19.05	7 400
20	30	20	22.225	9 900
22.5	33.5	22	25.4	14 600

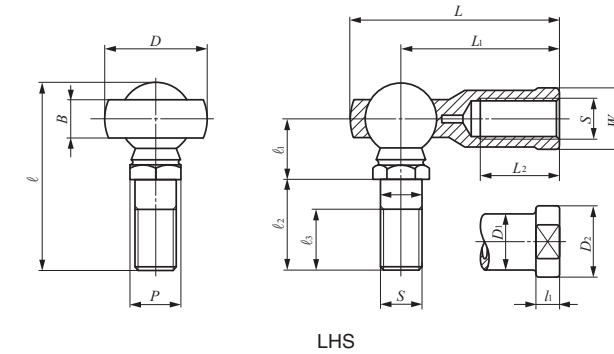
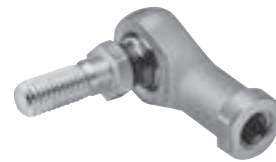

Identification number	Mass (Ref.) g	Thread S	Boundary dimensions mm											
			V	D	B	L	L ₁	L ₂	l ₁	W	D ₁	D ₂	ℓ	P
LHS 5	22	M 5×0.8	5	17	6	35.5	27	16	4	9	9	11	30.5	8
LHS 6	32	M 6×1	6	19.5	6.75	39.7	30	16	5	11	10	13	36.5	10
LHS 8	60	M 8×1.25	8	24	9	48	36	19	5	14	12.5	16	44	11
LHS 10	102	M10×1.5	10	28	10.5	57	43	23	6.5	17	15	19	52.5	13
LHS 12	160	M12×1.75	12	32	12	66	50	27	6.5	19	17.5	22	61	17
LHS 14	227	M14×2	14	36	13.5	75	57	30	8	22	20	25	69	17
LHS 16	300	M16×2	16	40	15	84	64	36	8	22	22	27	74	19
LHS 18	445	M18×1.5	18	45	16.5	93.5	71	40	10	27	25	31	84	22
LHS 20	580	M20×1.5	20	49	18	101.5	77	43	10	30	27.5	34	90.5	24
LHS 22	765	M22×1.5	22	54	20	111	84	47	12	32	30	37	99	27

Remark No grease is prepacked. Perform proper lubrication.

l ₁	l ₂	l ₃	Ball dia.	Static load capacity	
				C _s	N
10	15	11	11.112	2 080	
11.5	18.5	14	12.7	3 290	
14.5	21.5	15	15.875	4 900	
17	26	18	19.05	7 640	
20	30	20	22.225	12 400	
22.5	33.5	22	25.4	14 600	
24.5	35.5	23	28.575	19 500	
27.5	40.5	25	31.75	25 600	
30	43	27	34.925	31 600	
32.5	47.5	30	38.1	39 800	

L-BALL

L-Ball Dust Cover

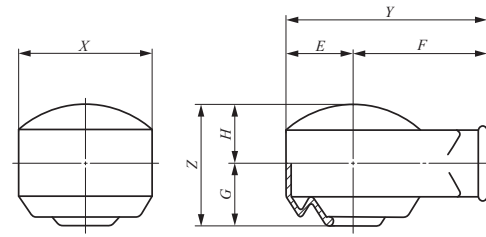

PRC

Identification number	Boundary dimensions mm						
	<i>X</i>	<i>Y</i>	<i>E</i>	<i>F</i>	<i>Z</i>	<i>G</i>	<i>H</i>
PRC 5	20	29	10	19	16	8	8
PRC 6	22	31	11	20	19	9.5	9.5
PRC 8	27	38.5	13.5	25	24	12	12
PRC 10	31	45.5	15.5	30	27	14	13
PRC 12	36	53	18	35	32	16.5	15.5
PRC 14	40	60	20	40	36.5	19	17.5
PRC 16	44	68	22	46	40	20.5	19.5
PRC 18	49	74.5	24.5	50	46	23.5	22.5
PRC 20	54	82	27	55	50	25.5	24.5
PRC 22	59	89.5	29.5	60	53.5	27.5	26



K

LHSA
LHS