

Mounted Ball Bearings *Browning*

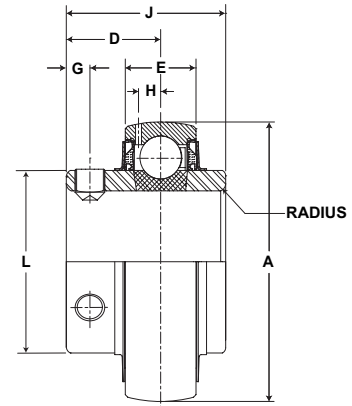

Duty: Standard
Rolling Elements: Ball
Outer: Spherical O.D.
Lock: Setscrew
Seal: Contact and Flinger
Temperature: -20° to 200°F



VS 200 Series Standard Duty Inserts - Setscrew Locking - Inch

Bore Diameter inch	Part No.	Basic Dynamic Rating lb/N	Dimensions inch / mm							Max. Rad. To Clear	Setscrew Thread	Unit Wt. lb/kg
			A	D	E	G	H	J	L			
1/2	VS-208	2108	1.5748	5/8	.512	5/32	9/64	1 1/32	31/32	.040	10-32	.4
5/8	VS-210	9377	40	15.9	13	4.0	3.6	26.2	24.6	1.0		.18
3/4	VS-212	2611 11614	1.8504 47	23/32 18.3	.591 15	3/16 4.8	5/32 4.0	1 7/32 31.0	1 3/16 30.2	.040 1.0	1/4-28	.4 .18
7/8	VS-214	2801	2.0472	13/16	.591	7/32	5/32	1 3/8	1 3/8	.040	1/4-28	.6
15/16	VS-215	12459	52	20.6	15	5.6	4.0	34.9	34.9	1.0		.27
1	VS-216											
1 1/8	VS-218	4381	2.4409	7/8	39/55	7/32	13/64	1 1/2	1 19/32	.040	1/4-28	.9
1 3/16	VS-219	19487	62	22.2	18	5.6	5.2	38.1	40.5	1.0		.41
1 1/4	VS-220S											
1 1/4	VS-220	5782	2.8346	1	.748	1/4	15/64	1 11/16	1 55/64	.040	5/16-24	1.2
1 3/8	VS-222	25718	72	25.4	19	6.4	6.0	42.9	47.2	1.0		.54
1 7/16	VS-223											
1 1/2	VS-224	7340 32648	3.1496 80	1 3/16 30.2	.866 22	5/16 7.9	17/64 6.7	1 15/16 49.2	2 1/16 52.4	.062 1.6	5/16-24	1.5 .68
1 5/8	VS-226	7901	3.3465	1 3/16	.866	5/16	17/64	1 15/16	2 19/64	.062	5/16-24	1.6
1 11/16	VS-227	35144	85	30.2	22	7.9	6.7	49.2	58.3	1.6		.73
1 3/4	VS-228											
1 15/16	VS-231	7889	3.5433	1 9/32	.906	3/8	9/32	2 1/32	2 15/32	.062	3/8-24	1.8
2	VS-232S	35090	90	32.5	23	9.5	7.1	51.6	62.7	1.6		.82
2	VS-232	9752	3.9370	1 5/16	.984	3/8	5/16	2 3/16	2 23/32	.080	3/8-24	2.3
2 3/16	VS-235	43377	100	33.3	25	9.5	7.9	55.6	69.1	2.0		1.04
2 1/4	VS-236	11789	4.3307	1 9/16	1.063	7/16	11/32	2 9/16	2 63/64	.080	3/8-24	3.1
2 7/16	VS-239	52437	110	39.7	27	11.1	8.7	65.1	75.8	2.0		1.41